

外形尺寸

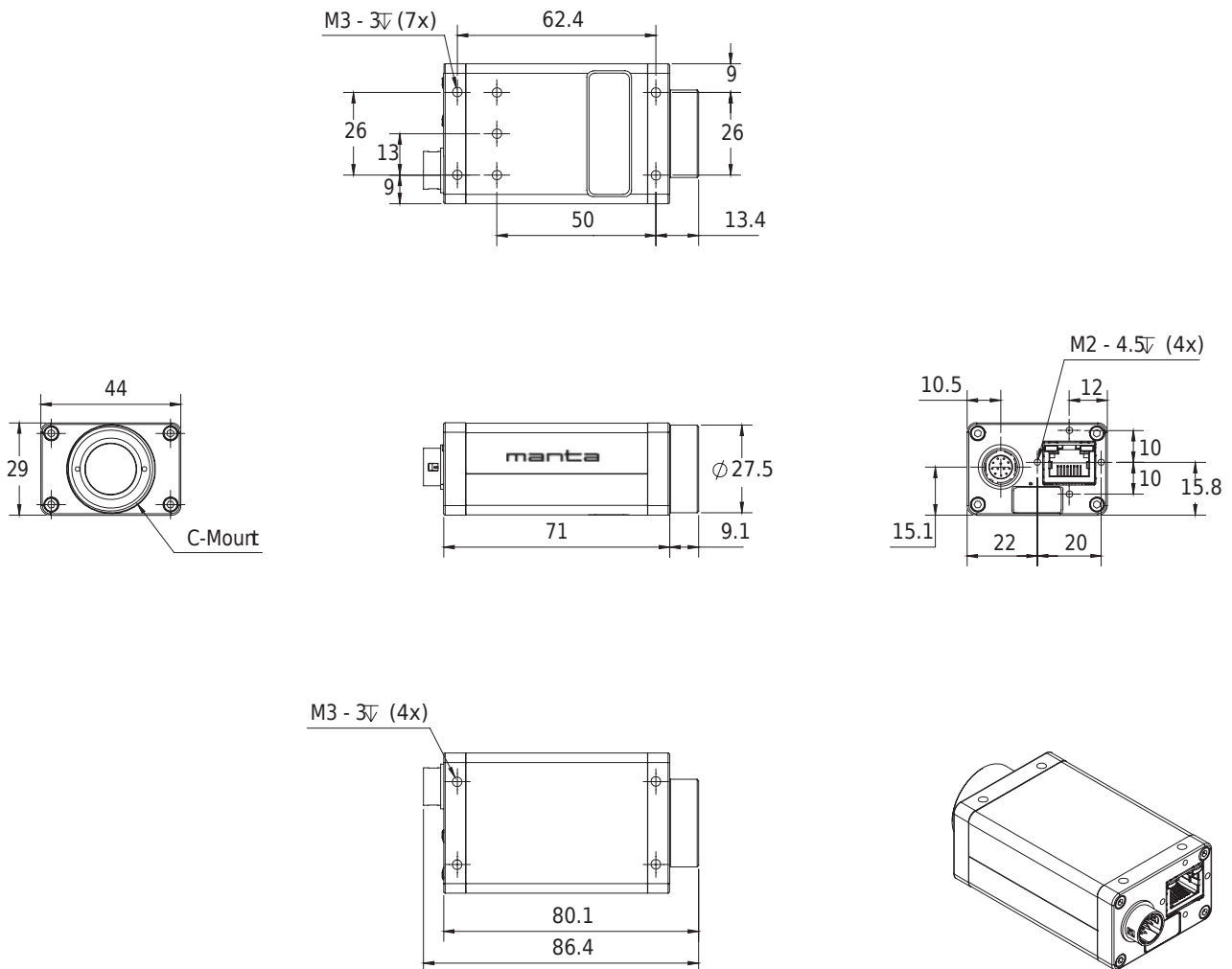

应用场景

Manta G-031 is suitable for a wide range of applications including:

- Machine vision
- Robotics
- Semiconductor inspection
- Logistics
- Security and Surveillance
- Pharmaceutical industry
- Food inspection