

BLACKFLY S

Industrial Machine Vision Camera | BFS-PGE-50Y2M/C

KEY FEATURES

Field Proven Sensor Upgrade

The onsemi AR0521 rolling shutter sensor is a direct replacement for the discontinued MT9P031 and MT9P006. No optical changes are needed, making it ideal for seamless upgrades in industrial systems.

Compact Form, Exceptional Value

5 MP imaging in a standard “ice-cube” form factor. This design delivers high-quality performance and advanced features at a competitive price.

Advanced Camera Control

Achieve precise control with built-in features like Global Reset, Logic Blocks, Counters, and Timers. These capabilities enable efficient, on-camera automation for demanding applications.

APPLICATIONS

- Surface Mount Technology (SMT)
- Alignment Systems
- Lens Inspection
- Surveillance

GIGE
VISION

GEN<i>i>CAM

Small Package, Powerful Results

The new Teledyne FLIR Blackfly S 5 MP GigE camera features the widely adopted onsemi® AR0521 rolling shutter sensor. This compact camera, measuring 29 x 29 x 30 mm, delivers outstanding imaging performance, making it ideal for system designers seeking high quality results without compromising on space or budget.

Blackfly S GigE cameras offer both automatic and precise manual control, along with built-in support for **on-camera pre-processing**. Unique to this model is the implementation of **Global Reset**, a first-of-its kind capability for the AR0521 sensor, which enables all pixels to start exposure simultaneously, reducing motion artifacts and improving image consistency in dynamic scenes. Combined with robust image control, this accelerates development and enhances productivity.

Designed as a **seamless drop-in** replacement for legacy Blackfly 5 MP models, this camera maintains the same GPIO and mechanical footprint, ensuring a smooth upgrade path. Users benefit from advanced functionality and better image quality without reworking their existing systems.



SPECIFICATIONS

	BFS-PGE-50Y2M-CS	BFS-PGE-50Y2C-CS
Resolution	2592 x 1944	
Base Frame Rate	24 FPS	
Megapixels	5.0 MP	
Sensor Size	1/2.5"	
Readout Method	Rolling Shutter with Global Reset	
Pixel Size	2.2 μ m	
Spectrum	Mono	Color
Lens Mount	CS-mount	
ADC	10-bit / 12-bit	
Minimum Frame Rate*	1.7 FPS	
Gain Range*	0 to 27 dB	
Exposure Range*	9 μ s to 0.58 seconds	
Acquisition Modes	Continuous, Single Frame, Multi Frame	
Partial Image Modes	Pixel binning, ROI	
Image Processing	Gamma, lookup table, and sharpness	Color correction matrix, gamma, lookuptable, saturation, and sharpness
Image Buffer	240 MB	
User Sets	2 user configuration sets for custom camera settings	
Flash Memory	6 MB non-volatile memory (for user-defined data)	
Opto-isolated I/O	1 input / 1 output	
Non-isolated I/O	1 bi-directional, 1 input	
Serial Port	1 over non-isolated I/O	
Auxiliary Output	3.3 V 120 mA maximum	
Interface	1 Gigabit Ethernet PoE	
Power Requirements	Power over Ethernet (PoE); or 12 V nominal (8 - 24 V)	
Power Consumption	3.5 W maximum PoE	
Dimensions / Mass	29 mm x 29 mm x 30 mm / 36 g	
Machine Vision Standard	GigE Vision v1.2	
Compliance	CE, FCC, KCC, RoHS, REACH. The ECCN for this product is: EAR099	
Temperature	Operating: 0°C to 50°C / Storage: -30°C to 60°C	
Humidity (no condensation)	Operating: 20% - 80% / Storage: 30% - 95%	
Warranty	3 years	

*Values are the same in binning and no binning modes.

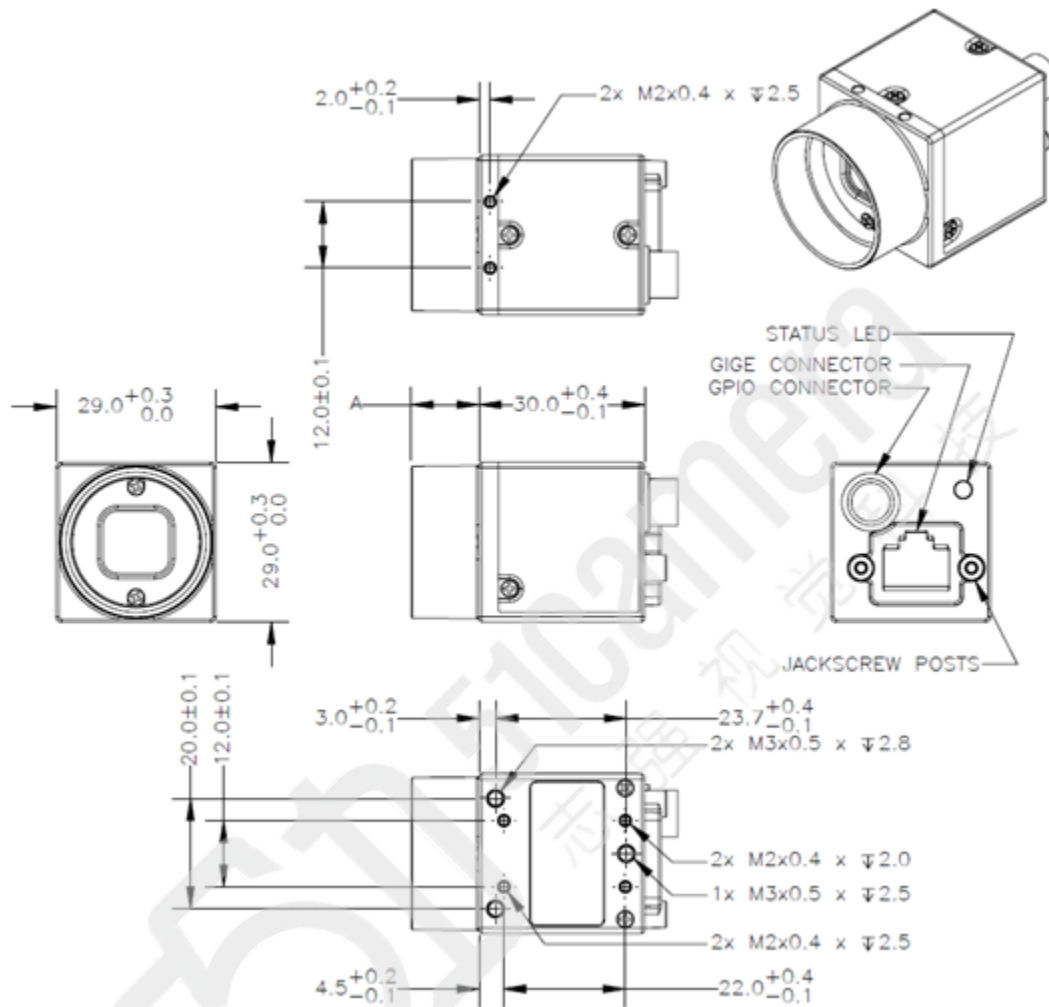
MECHANICAL DRAWINGS

FOR MORE INFORMATION CONTACT:
THE AMERICAS

+1 866.765.0827 (toll free) | +1 604.242.9937 | mv-sales@teledyne.com

ASIA PACIFIC

Japan: +81 3 6914 3826 | mv-japansales@teledyne.com

Korea: +82 2 565 2714 | mv-asiasales@teledyne.com

India: +91 11 4560 3555 | mv-asiasales@teledyne.com

RoA: mv-asiasales@teledyne.com

EUROPE, MIDDLE EAST, & AFRICA

+49 7141 488817-0 | mv-eusales@teledyne.com

Greater China

Beijing: +86 10 8466 9678 ext.8019 | mv-chinasales@teledyne.com

Shanghai: +86 21 6013 1571 | mv-chinasales@teledyne.com

Taiwan: +886 978380931 | mv-taiwansales@teledyne.com

This document does not contain information whose export/transfer/disclosure is restricted by the Canadian Export Control regulation. Teledyne FLIR reserves the right to make changes at any time without notice.
 © 2025 Teledyne FLIR

Revision Date: 2025 10 14