

Piranha XL XDR 16K

eXtended Dynamic Range Multi-line CMOS TDI Camera

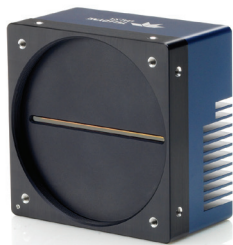

Multi-line CMOS TDI camera delivering breakthrough performance

Teledyne DALSA presents our latest multi-line CMOS camera, delivering an unprecedented combination of speed and responsivity with low noise. Exposure control allows for seamless variable speed imaging down to stopped conditions on select models.

The camera uses the Camera Link HS interface based on Teledyne DALSA's field-proven HS Link technology. It delivers very high data throughput with long transmission distances and reliability. The camera, combined with the XTNUM Camera Link HS frame grabber, offers a complete solution for the next generation Automatic Optical Inspection.

Key Features

- True exposure control
- High speed 125 kHz line rate
- Highly responsive multi-line CMOS architecture
- 16k pixel resolution with $5\ \mu\text{m} \times 5\ \mu\text{m}$ pixel size
- Very low noise
- High dynamic range using a look-up table (LUT)
- Binning
- Stop / Start seamless imaging (PX-HM-16K06X-00-R)
- Bidirectional scanning
- Smart lens shading correction
- Field proven Camera Link HS interface
- Multiple user sets
- Fibre optic module support

Programmability

- Adjustable responsivity
- Multiple areas of interest (AOI) for data reduction
- Multiple regions of interest (ROI) for easy calibration
- Lens and shading correction
- Test pattern and diagnostics

Typical Applications

- Flat panel display inspection
- Film and web inspection
- Printed circuit board inspection
- High throughput and high resolution applications

Specifications

Resolution	16,352 x 12 pixels
Max Line Rate	125 kHz (single cable)
Pixel Size	$5\ \mu\text{m} \times 5\ \mu\text{m}$
Row Selection	8 or 12 rows
Data Format	8 or 12 bit, selectable
Output	Camera Link HS (1 or 2 cables)
Lens Mount	M90 x 1 mm
Responsivity	1200 DN/(nJ/cm ²), 12 bit, 1x gain
Responsivity Range	23x min to max
NEE	6.5 pJ/cm ² @ 620 nm
Nominal Gain Range	Up to 10x
Antiblooming	> 100x
Size	97 (W) x 97 (H) x 61 (D) mm
Mass	685 g
Operating Temp	0 to 60 °C (front plate)
Power	Hirose 6-pin, +12 V to + 24 V DC
Power Dissipation	23 W, typical
Control & Data	Camera Link HS
Regulatory Compliance	CE and RoHS
Part Number	PX-HM-16K12X-00-R (125 kHz model) PX-HM-16K06X-00-R (60 kHz model)



Piranha XL XDR 16K

eXtended Dynamic Range Multi-line CMOS TDI Camera

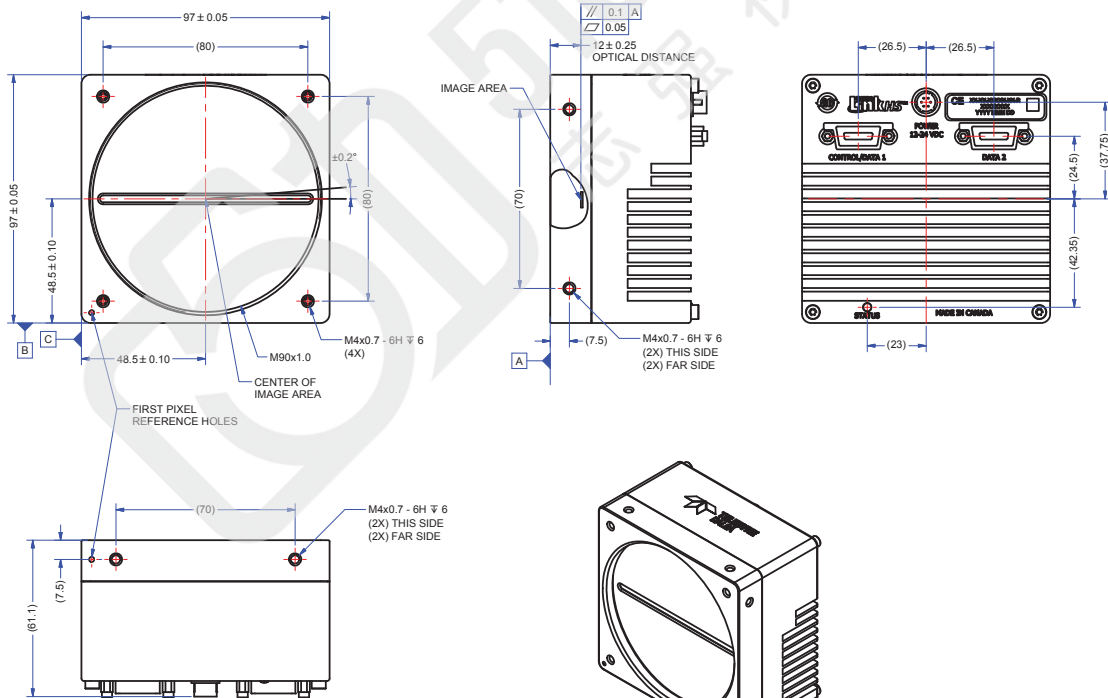
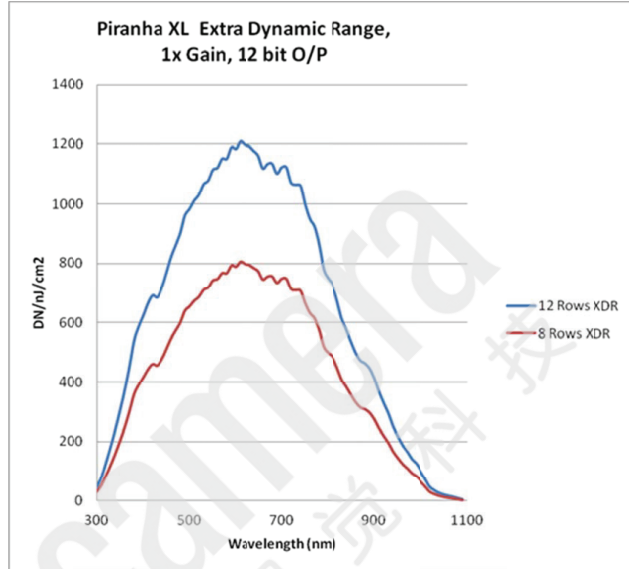

www.teledynedalsa.com

NOTES:
1. UNITS: MILLIMETERS.
2. IMAGE AREA IS ALIGNED TO DATUMS A, B & C.

Americas

Boston, USA
+1 978-670-2000
sales.americas@teledynedalsa.com

Europe

Krailling, Germany
+49 89-89-54-57-3-80
sales.europe@teledynedalsa.com

Asia Pacific

Tokyo, Japan
+81 3-5960-6353
sales.asia@teledynedalsa.com

Shanghai, China
+86 21-3368-0027
sales.asia@teledynedalsa.com

Teledyne DALSA has its corporate offices in Waterloo, Canada
Teledyne DALSA reserves the right to make changes at any time without notice. Teledyne DALSA © 2016.
Revision number 03-070-20095-00. Revision date February 26P, 2016.

