

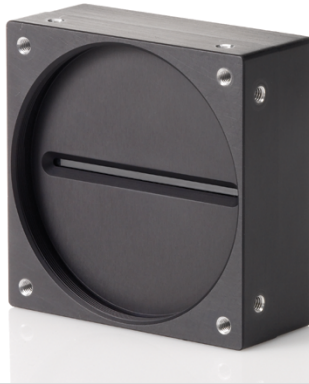

Linea Color 8K Camera Link

CMOS Line Scan Cameras



High Performance and Low Cost. Now in Color

The new Linea Color™ line scan camera delivers the exceptional performance and features found in Teledyne DALSA's current lineup of high-end cameras at an unprecedented price point.

Based on bilinear CMOS technology, the Linea Color camera has an 8k, 7.04 μm x 7.04 μm pixel array, and a 48 kHz maximum line rate. With excellent sensitivity and speed, Linea Color surpasses the requirements of demanding applications—such as materials grading, web inspection, and general purpose machine vision.

The Linea Color is a compact, light weight and robust camera with many attractive features, including flat-field correction, multiple ROI and AOI, multiple user configuration sets, and calibration coefficients for various lighting conditions.

The GenICam™ compliant Linea is easy to set up and integrate using a GUI, such as Teledyne DALSA's Sopera™ camera configuration utility CamExpert.

Key Features

- High speed: up to 48 kHz
- 8192 x 2 pixel resolution
- Low cost and compact
- Camera Link interface

Programmability

- Multiple regions of interest and areas of interest for calibration and data reduction
- 8 or 12 bit output, selectable
- Smart flat field and lens shading correction
- 8 programmable coefficient sets

Typical Applications

- Automated optical inspection
- High performance sorting systems
- Materials grading
- Web inspection
- General purpose machine vision

Regulatory Compliance

- CE, FCC and RoHS

Specifications

Resolution	8192 x 2 pixels
Line Rate	48 kHz, maximum
Pixel Size	7.04 μm x 7.04 μm
Data Format	8 or 12 bit selectable
Output	Base, Medium, Full, and Deca Camera Link
Lens Mount	M72 x 0.75, F-mount adapter available
Responsivity	See graph
Dynamic Range	> 60 dB
Nominal Gain Range	10x
Size	76.0 mm x 76.0 mm x 36.72 mm
Mass	< 310 g
Operating Temp	0 °C to +65 °C (front plate)
Power	12 V to 24 V DC, Hirose 6-pin
Power Dissipation	11 W
Control & Data	SDR-26 mini Camera Link

Models			
Part Number	Resolution	Maximum Line Rates	Pixel Size
LA-CC-08K05B-00-R	8192 x 2	48 kHz	7.04 μm x 7.04 μm



Linea Color 8K Camera Link

CMOS Line Scan Cameras

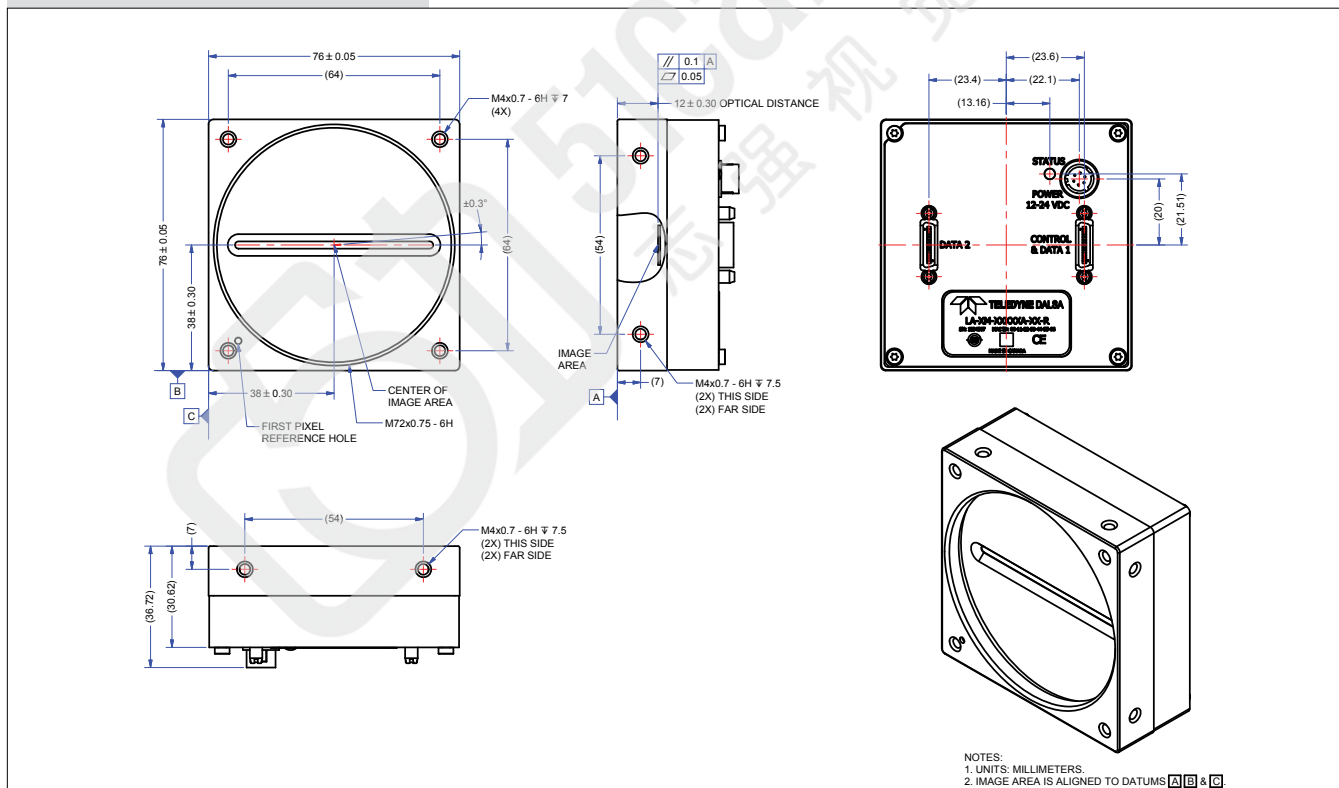
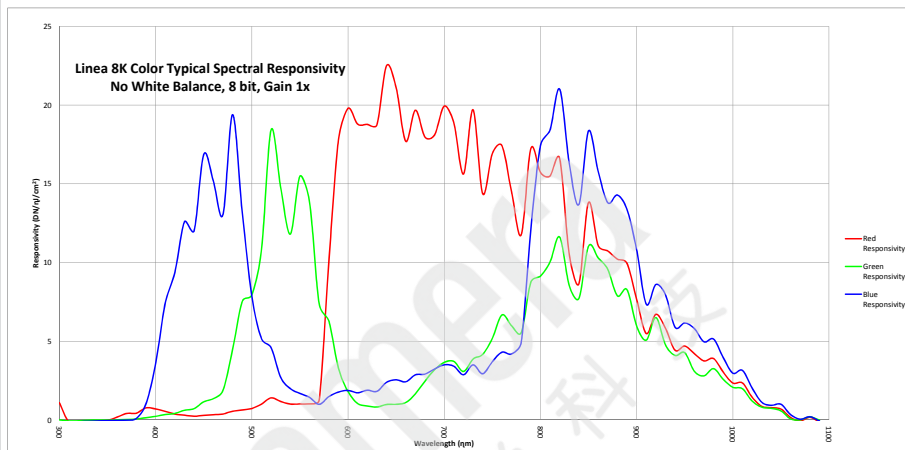

www.teledynedalsa.com

Americas

Boston, USA
+1 978-670-2000
sales.americas@teledynedalsa.com

Europe

Krailling, Germany
+49 89-89-54-57-3-80
sales.europe@teledynedalsa.com

Asia Pacific

Tokyo, Japan
+81 3-5960-6353
sales.asia@teledynedalsa.com

Shanghai, China
+86 21-6427-9081

sales.asia@teledynedalsa.com

Teledyne DALSA has its corporate offices in Waterloo, Canada
Teledyne DALSA reserves the right to make changes at any time without notice. Teledyne DALSA © 2016.
Revision number 03-070-20092-02. Revision date October 31, 2016.

