

Linea 2K and 4K GigE Vision

Monochrome CMOS Line Scan Cameras

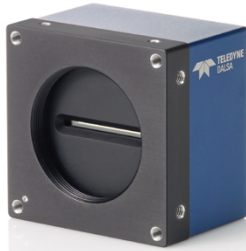

High Performance Monochrome GigE Camera with TurboDrive

The new Linea™ line scan cameras deliver the exceptional performance and features found in Teledyne DALSA's current lineup of high-end cameras at an unprecedented price point.

Based on the most advanced CMOS line scan technology, the Linea GigE cameras have a 2k or 4k single line 7.04 μm x 7.04 μm pixel array. With excellent sensitivity and speed, Linea surpasses the requirements of demanding applications—such as materials grading and inspection, transportation safety, and general purpose machine vision.

The Linea cameras come complete with many features, including cycling mode, configurable GPIO ports, burst mode and meta data per each line. Like the Camera Link models, the GigE models provide multiple ROI and AOI, and multiple user and calibration coefficients sets for various lighting conditions.

Our proprietary, patent pending, TurboDrive™ technology delivers high speed data transfer capability that breaks through the GigE limit. Depending on the application, speeds up to 80 kHz are achievable, as TurboDrive boosts data transfer 2 or 3 times faster than standard GigE Vision™ speeds – with no loss of image quality.

Key Features

- Low cost
- Cycling mode
- Compact
- Burst mode
- Meta data per each line

Programmability

- Multiple regions of interest and areas of interest for calibration and data reduction
- 8 or 12 bit output, selectable
- Smart flat field and lens shading correction
- 4 programmable coefficient sets
- Configurable GPIO ports, timers and counters

Typical Applications

- Automated optical inspection
- High performance sorting systems
- Materials grading and inspection
- Web inspection
- General purpose machine vision

Regulatory Compliance

- CE, FCC and RoHS

Specifications

Resolution	2048 or 4096 pixels
Line Rate	52 kHz, maximum—2k models without TurboDrive 26 kHz, maximum—4k models without TurboDrive (80 kHz, maximum—both models with TurboDrive)
Pixel Size	7.04 μm x 7.04 μm
Data Format	8 or 12 bit selectable
Output	Gigabit Ethernet
Lens Mount	M42 x 1, C and F-mount adapters available
Responsivity	320 DN / (nJ / cm ²) in 12 bit at 1x gain
Dynamic Range	> 60 dB
Nominal Gain Range	1x to 10x
Size	62 mm x 62 mm x 46.7 mm
Mass	< 280 g
Operating Temp	0 °C to 65 °C (front plate)
Power	12 V to 24 V DC, HD15 connector (shared with I / O)
Power Dissipation	< 6 W
I / O	HD15 connector
Software Platform	GigE Vision v1.2 compliant Teledyne DALSA Sopera LT or 3rd party GenICam™ compliant SDK

Models			
Part Number	Resolution	Maximum Line Rates	Pixel Size
LA-GM-02K08A-00-R	2048	52 kHz without TurboDrive (80 kHz with TurboDrive)	7.04 μm x 7.04 μm
LA-GM-04K08A-00-R	4096	26 kHz without TurboDrive (80 kHz with TurboDrive)	7.04 μm x 7.04 μm

Linea 2K and 4K GigE Vision

Monochrome CMOS Line Scan Cameras

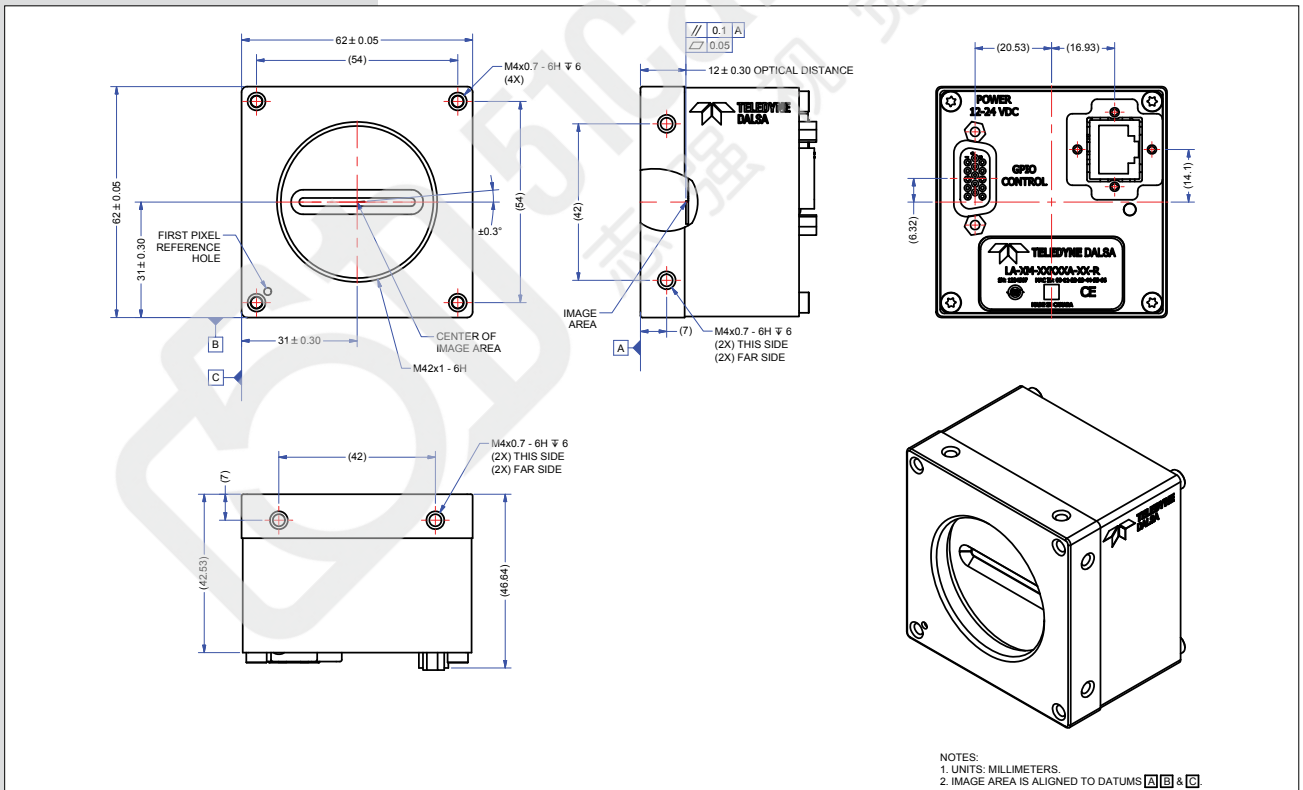
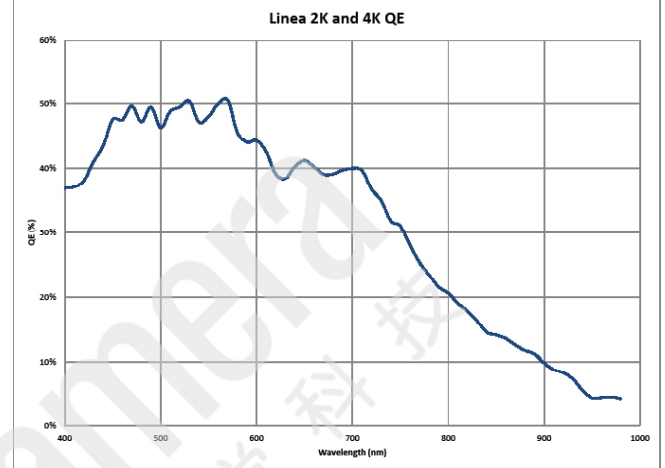
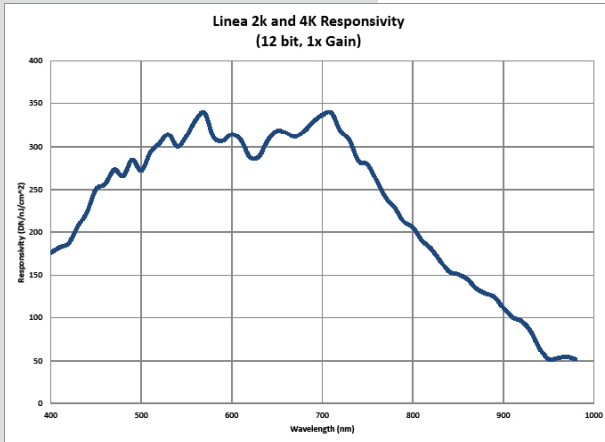

www.teledynedalsa.com

Americas
 Boston, USA
 +1 978-670-2000
sales.americas@teledynedalsa.com

Europe
 Krailling, Germany
 +49 89-89-54-57-3-80
sales.europe@teledynedalsa.com

Asia Pacific
 Tokyo, Japan
 +81 3-5960-6353
sales.asia@teledynedalsa.com

Shanghai, China
 +86 21-6427-9081
sales.asia@teledynedalsa.com

Teledyne DALSA has its corporate offices in Waterloo, Canada
 Teledyne DALSA reserves the right to make changes at any time without notice. Teledyne DALSA © 2016.
 Revision number 03-070-20083-04. Revision date October 31, 2016.

