

# Matrox Indio

Installation and Hardware Reference

Manual no. Y11398-101-0104

October 5, 2022

*Matrox® is a registered trademark of Matrox Electronic Systems Ltd.*

*EtherNet/IP™ is a trademark of ODVA, Inc.*

*GigE Vision® is a registered trademark of the AIA.*

*Intel® is a registered trademark of Intel Corporation.*

*Linux® is a registered trademark of Linus Torvalds.*

*Microsoft® and Windows® are registered trademarks of Microsoft Corporation.*

*Modbus® is a registered trademark of MODICON, Inc.*

*PCIe® is a registered trademark of PCI-SIG.*

*PROFINET® is a registered trademark of PROFIBUS and PROFINET International (PI).*

*Siemens® is a registered trademark of Siemens AG, and Siemens Totally Integrated Automation (TIA) Portal™ is a trademark of Siemens AG.*

*All other nationally and internationally recognized trademarks and tradenames are hereby acknowledged.*

*© Copyright Matrox Electronic Systems Ltd., 2016-2022. All rights reserved.*

*1055 St-Regis Blvd. Dorval, Quebec, Canada H9P 2T4*

*Web: [www.matrox.com](http://www.matrox.com)*

*Limitation of Liabilities: In no event will Matrox or its suppliers be liable for any indirect, special, incidental, economic, cover or consequential damages arising out of the use of or inability to use the product, user documentation or related technical support, including without limitation, damages or costs relating to the loss of profits, business, goodwill, even if advised of the possibility of such damages. In no event will Matrox and its suppliers' liability exceed the amount paid by you, for the product.*

*Because some jurisdictions do not allow the exclusion or limitation of liability for consequential or incidental damages, the above limitation may not apply to you.*

*Disclaimer: Matrox Electronic Systems Ltd. reserves the right to make changes in specifications at any time and without notice. The information provided by this document is believed to be accurate and reliable. However, neither Matrox Electronic Systems Ltd. nor its suppliers assume any responsibility for its use; or for any infringements of patents or other rights of third parties resulting from its use. No license is granted under any patents or patent right of Matrox Electronic Systems Ltd.*

*PRINTED IN CANADA*

# Contents

---

## **Chapter 1: Before you begin** . . . . . 7

Matrox Indio overview . . . . .	8
Auxiliary, multi-purpose signals. . . . .	9
Communication over Ethernet . . . . .	10
Data transfer . . . . .	10
Software . . . . .	10
Essentials to get started . . . . .	12
Inspecting the Matrox Indio package . . . . .	12
Standard items . . . . .	12
Available separately . . . . .	12
General warnings and key to symbols on the board . . . . .	13
Matrox Indio safety precautions and key to symbols . . . . .	13
Handling precautions . . . . .	14
Manual overview . . . . .	15

---

## **Chapter 2: Hardware installation** . . . . . 17

Installing your Matrox Indio board . . . . .	18
Connecting to peripheral devices over an Ethernet connection . . . . .	21
Using a PoE device with your Matrox Indio board . . . . .	22
Network connections for Industrial communications . . . . .	22
Connecting to the auxiliary I/O interface . . . . .	23
Connecting devices to the auxiliary output signals . . . . .	24
Connecting an auxiliary output signal to a sinking input . . . . .	31
Connecting an auxiliary output signal to a sourcing input . . . . .	32
Connecting an auxiliary output signal to an inductive load input . . . . .	33
Connecting an auxiliary output signal to a TTL-compatible input . . . . .	34

Connecting devices to the auxiliary input signals . . . . .	36
Connecting a sourcing output to an auxiliary input signal . . . . .	41
Connecting a sinking output to an auxiliary input signal . . . . .	42
Connecting a 3-wire PNP proximity sensor to an auxiliary input signal . . . . .	43
Connecting a 3-wire NPN proximity sensor to an auxiliary input signal . . . . .	44
Connecting a 2-wire proximity sensor to an auxiliary input signal . . . . .	45
Connecting a TTL-compatible output to an auxiliary input signal . . . . .	47

---

**Chapter 3: Using multiple Matrox Indio boards . . . . . 49**

Installation of multiple boards . . . . .	50
Simultaneous image capture from different boards . . . . .	50

---

**Chapter 4: Matrox Indio hardware reference . . . . . 51**

Matrox Indio hardware reference . . . . .	52
Advanced I/O engine . . . . .	53
Auxiliary I/O interface . . . . .	53
Timers . . . . .	55
Rotary decoders . . . . .	56
I/O command lists . . . . .	56
User-output register . . . . .	57
Communication over Ethernet . . . . .	58
Power-over-Ethernet . . . . .	60
Data transfer . . . . .	60

---

**Appendix A: Glossary . . . . . 61**

Glossary . . . . .	62
--------------------	----

---

**Appendix B: Technical information . . . . . 65**

Board summary . . . . .	66
-------------------------	----

Global information . . . . .	66
Technical features . . . . .	66
Electrical specifications . . . . .	69
Dimensions and environmental specifications . . . . .	71
Matrox Indio connectors . . . . .	72
Auxiliary I/O connector . . . . .	73
Gigabit Ethernet connector . . . . .	77
Input and output mode connectors . . . . .	77
Input mode connectors . . . . .	77
Output mode connectors . . . . .	78
LEDs on Matrox Indio . . . . .	79
Gigabit Ethernet status LEDs . . . . .	79
Auxiliary I/O status LEDs . . . . .	80
Hardware-assisted PROFINET LED . . . . .	81

---

***Index***

---

***Regulatory compliance***

---

***Limited Warranty***



**Chapter**

# 1

## **Before you begin**

This chapter describes the features of the Matrox Indio board, important usage precautions, and the software that can be used with this board.





## Auxiliary, multi-purpose signals

Matrox Indio features an auxiliary I/O interface that can transmit and receive optically isolated, digital, 24 V/TTL-level auxiliary signals; it supports 8 input and 8 output auxiliary signals. The auxiliary I/O interface is controlled by an advanced I/O engine. The auxiliary input signals can trigger functionality in the engine (for example, a signal can trigger a timer in the engine). In addition, the auxiliary input signals can cause software events or can be transmitted to third-party devices over an auxiliary output signal. The auxiliary output signals can output a signal generated in the advanced I/O engine (for example, a timer output) or the state of a bit of one of the engine's registers (for example, the user-output register which is set using software).

The advanced I/O engine includes:

- 16 timers that can be run in continuous or triggered mode and can use a selectable clock source.
- Two rotary decoders that can decode quadrature input received from a rotary encoder with quadrature output.
- Two I/O command lists that allow you to schedule commands to change the state of a bit of an I/O command register at a specified time or counter value. You can route the state of the bit to an auxiliary output signal to control a connected device at a required moment; the state of each bit can be routed to any of the auxiliary output signals or can be used, for example, to trigger a timer. You can use an I/O command list, for example, when multiple parts are traveling between a sensor and one or more ejector(s) and you need to schedule the ejection/redirection of the different parts based on some analysis.
- An 8-bit user-output register that allows you to manually set the state of an auxiliary output signal to transmit application-specific user output.

All auxiliary signals support voltages up to 24 V in sinking or sourcing configurations<sup>1</sup>.

---

1. Typically, for an auxiliary signal to source voltage, you must attach an external power source to Matrox Indio. However, if you enable TTL mode for an auxiliary signal, it can source up to 5 V without an external power source (through an on-board pullup circuit connected to an isolated 5V power rail).

## **Communication over Ethernet**

Matrox Indio has a Gigabit Ethernet network interface that has built-in power-over-Ethernet (PoE) support, whereby the power source is electrically isolated from the rest of your computer.

Although you can use the network interface for general purpose, Gigabit network communication, the interface is intended for grabbing from GigE Vision-compatible cameras, or for communicating with external devices (for example, a PLC) using the PROFINET, EtherNet/IP, or Modbus industrial protocol. For PROFINET communication, Matrox Indio includes a PROFINET engine that, if enabled, provides a hardware-assisted PROFINET interface that supports a minimum I/O cycle time of 1 msec.

When communicating with an external device using an industrial protocol and your process relies on a specific response time, it is not recommended to also use the network interface for grabbing or general network traffic, unless using the hardware-assisted PROFINET interface.

## **Data transfer**

Matrox Indio is a x1 PCIe Gen 2 board, so it can transfer data over any PCIe slot. Under optimum conditions, Matrox Indio can exchange data with the Host at a peak transfer rate of up to 500 Mbytes/sec if the board is installed in a PCIe Gen 2 slot.

## **Software**

---

To operate Matrox Indio, you can use one or more Matrox Imaging software products that supports the board. These are the Matrox Imaging Library (MIL) and its derivatives (for example, MIL-Lite and Matrox Capture Assistant). All Matrox software is supported under Windows; MIL is also supported under Linux when using Matrox Indio. Consult your software manual for supported versions of these operating systems.

- MIL** MIL is a high-level programming library with an extensive set of optimized functions for image capture, processing, analysis, transfer, compression, display, and archiving. Image processing operations include point-to-point, statistical, spatial filtering, morphological, geometric transformation, and FFT operations. Analysis operations support calibration, are performed with sub-pixel accuracy, and include pattern recognition (normalized grayscale correlation and Geometric Model Finder), blob analysis, edge extraction and analysis, measurement, image registration, metrology, character recognition (template-based, and for both normal and dot-matrix text, feature-based), code recognition and verification (1D, 2D and composite code types), bead (continuous strips of material) inspection, 3D reconstruction, and color analysis.
- MIL applications are easily ported to new Matrox hardware platforms and can be designed to take advantage of multi-processing and multi-threading environments.
- MIL-Lite** MIL-Lite is a subset of MIL. It includes all the MIL functions for image acquisition, transfer, display control, and archiving. It also allows you to perform processing operations that are typically useful to pre-process grabbed images.
- Matrox Capture Assistant** Matrox Capture Assistant is a utility that allows you to rapidly test and evaluate the performance of virtually any GenICam-compliant device using MIL<sup>1</sup> (for example, GigE Vision compatible devices). It can also be used to configure Gbit Ethernet network adapter settings and Matrox-specific configuration settings.

- 
1. Unlike when using other Matrox imaging boards, image acquisition with Matrox Indio is made possible because the operating system recognizes the GigE Ethernet network interface as another network port. So when you allocate a MIL GigE Vision system (using MIL or one of its derivatives), you can grab from GigE Vision-compatible devices connected to the Gigabit Ethernet network interface. For all other functionality on the board, you must allocate a MIL Matrox Indio system. Matrox Capture Assistant can allocate and interface with a MIL GigE Vision system, and not with a MIL Matrox Indio system. Refer to MIL documentation for more information.

## Essentials to get started

---

To begin using your Matrox Indio, you must have a computer with the following:

- The board fits in a PCIe Gen 1 or Gen 2 slot. A PCIe Gen 2 slot will ensure the fastest possible transfer of data to the Host. If Matrox Indio must provide power to a connected device using PoE, Matrox Indio must be installed in a PCIe slot that meets the electrical requirements detailed in the *Electrical specifications* section, in *Appendix B: Technical information*.
- A computer with an Intel 32-bit or 64-bit architecture, or equivalent.
- A relatively up-to-date PCIe computer; one that supports the PCIe Gen 2 standard is preferable. For the list of platforms compatible with Matrox Indio, refer to the Matrox Imaging website.
- MIL or one of its derivatives. It is recommended that you install this software after you install your board. Consult your software package for other computer requirements (for example, operating system and memory requirements)

For more information, consult with your local Matrox Imaging representative.

## Inspecting the Matrox Indio package

---

You should check the contents of your Matrox Indio package when you first open it. If something is missing or damaged, contact your Matrox representative.

### Standard items

You should receive the following items:

- Matrox Indio board.
- 16 jumpers that you can use to configure the mode of each auxiliary signal.

### Available separately

You might have also ordered one or more of the following:



- MIL or MIL-Lite. Matrox Capture Assistant is included with all of these software packages.

## General warnings and key to symbols on the board

You should be aware of the meaning of the symbols on the board and important usage and handling precautions.

### Matrox Indio safety precautions and key to symbols

Before installing, connecting to, and using Matrox Indio, you should be aware of the meaning of the symbols on the board and important safety precautions. The following is a list of precautionary symbols on the board and their meaning:

Symbol <sup>1</sup>	Precaution
	<ul style="list-style-type: none"> <li>• Caution: Consult this manual<sup>2</sup> before installing, connecting to, and using Matrox Indio. For hardware installation instructions, refer to <i>Chapter 2: Hardware installation</i>; for environmental and electrical specifications and connector pinout descriptions, refer to <i>Appendix B: Technical information</i>.</li> <li>• This product must be used as specified; otherwise, the protection provided by its components might be compromised.</li> <li>• Refer to the Electrical specifications section, in Appendix B: Technical information, for voltages and current ratings.</li> <li>• There are no serviceable parts on this product. In case of defect, contact your Matrox representative.</li> <li>• This product is intended to be used in a properly ventilated computer enclosure that has its cover installed. The cover ensures that internal components are not accessible.</li> <li>• Do not touch the product's components when it is under operation and/or when it is connected to external peripherals.</li> <li>• This product meets the requirements of a Category I installation as per industry standards<sup>3</sup>.</li> <li>• This product is designed for use in a pollution degree 2 environment as per industry standards<sup>3</sup>.</li> <li>• This product is designed for indoor use only.</li> <li>• This product is designed to operate at temperatures ranging from 0°C to 55°C at a non-condensing relative humidity of 10 to 90%.</li> <li>• This product is not intended for use at altitudes exceeding 2000 m.</li> </ul>
	<p>DC current only.</p> <p>Matrox Indio draws up to 0.9 A from the 3.3 VDC power rail and up to 1.7 A from the 12 VDC power rail. Make sure that the Host computer can supply these and still meet the power requirements of the other devices of the computer.</p>

1. Not necessarily in the same color.

2. Manual available on the Matrox Imaging website at <http://www.matrox.com/imaging>

3. As per CAN/CSA-C22.2 No 61010-1-12, UL std. No 61010-1 (3rd edition), and EN Std. No. 61010-1 (3rd Edition)

### **Handling precautions**

The electronic circuits in your computer and the circuits on your Matrox Indio board are sensitive to static electricity and surges. Improper handling can seriously damage the circuits. Be sure to drain static electricity from your body by touching a metal fixture (or ground) before you touch any electronic component. In addition, do not let your clothing come in contact with the circuit boards or components.

### **Caution**

Before you add or remove devices from your computer, always turn off the power to your computer and all peripherals. In addition, unplug your computer because even if it is turned off, auxiliary power is still present on the PCIe slot connector.

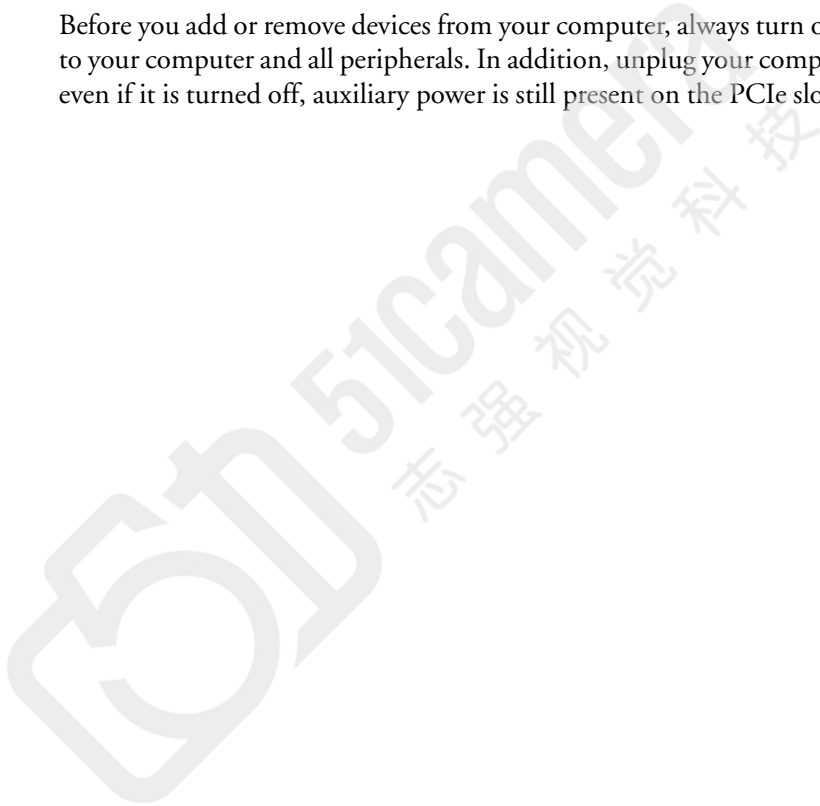

## Manual overview

---

This installation and hardware reference explains how to install your Matrox Indio board and connect to external devices.

This manual contains the following information:

- *Chapter 1: Before you begin* introduces you to the key features of the Matrox Indio board.
- *Chapter 2: Hardware installation* details how to install your Matrox Indio board and connect various peripherals to the auxiliary I/O connector and Gigabit Ethernet connector.
- *Chapter 3: Using multiple Matrox Indio boards* describes how to install more than one Matrox Indio board in a computer and the implications of doing so.
- *Chapter 4: Matrox Indio hardware reference* provides more in-depth information about the Matrox Indio board.
- *Appendix A: Glossary* defines some of the terms used in this manual.
- *Appendix B: Technical information* provides a summary of the hardware information, environmental and electrical specifications, and connector pinout descriptions.

### Need help?

If you experience problems during installation or while using this product, you can refer to the support page on the Matrox Imaging web site: <http://www.matrox.com/imaging/en/support>. The support page provides answers to frequently asked questions and offers registered customers additional ways of obtaining support.

If your question is not addressed and you are registered, contact technical support. To do so, you should first complete and submit the online Technical Support Request Form, accessible from the above-mentioned web page. Once you have submitted the information, a Matrox support agent will contact you shortly thereafter by email or phone, depending on the problem.





Chapter

# 2

## Hardware installation

This chapter explains how to install your Matrox Indio board and how to connect peripherals to the board.



## Installing your Matrox Indio board

---

Before you install your Matrox Indio board, some precautionary measures must be taken. Drain static electricity from your body (by touching a metal part of the computer chassis). Then, turn off the power to your computer and its peripherals, and unplug your computer.

Note that it is recommended that you install your board before you install your software.

Proceed with the following steps to install your board:

1. Remove the cover of your computer; refer to your computer's documentation for instructions.
2. Check that you have an empty PCIe slot in which to install your Matrox Indio board. The board is a x1 PCIe board, so it will function in any PCIe slot. Note that a PCIe Gen 2 capable slot will ensure the fastest possible transfer of data with the Host.

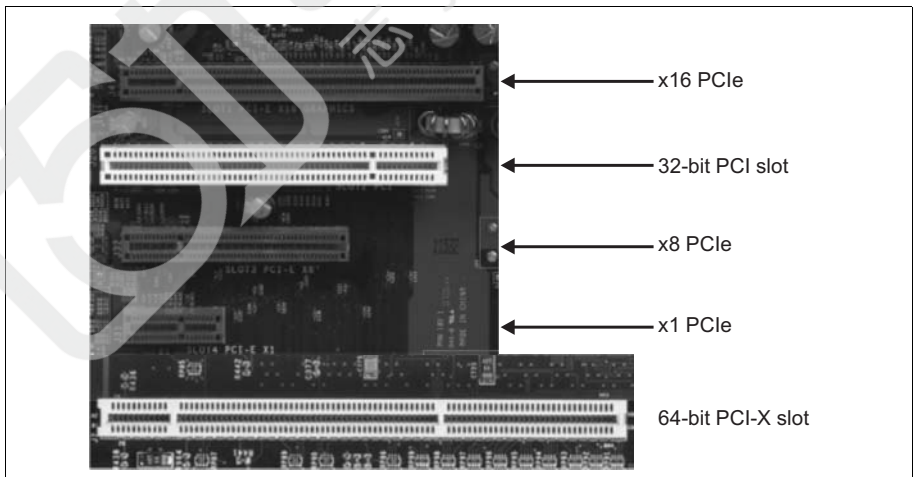

3. If there is a metal plate at the back of the selected slots, remove it. Keep the screw from the top of the plate to anchor your board once it is installed.

4. Position your Matrox Indio board in the selected PCIe slot. Align the connectors of your board with the opening at the back of the slot, and move the board until the connectors pass through the opening.
5. Once the connectors are in the opening of the chassis, press the board firmly but carefully straight down into the connector of the slot.
6. Anchor the board using the screw that you removed in step 3.
7. Reinstall the cover of your computer.
8. Attach your peripherals, as described, later in this chapter.

**Caution**

Ensure that your computer and the peripheral are powered off before adding or removing the peripheral.

9. Turn on your computer. If you have not yet installed the software for the board, note that when you boot your computer under Windows, Windows' Plug-and-Play system will detect that the device driver for a PCI Data Acquisition and Signal Processing Controller is not installed. This is expected and you should click on **Close**.

**Important**

10. Under Windows and Linux, you should select to install the driver(s) for the board during the installation of your Matrox Indio software. If you plan on acquiring images from a GigE Vision-compatible camera, you must select to install the Matrox GigE Vision driver. For all other functionality on the board, you must select to install the Matrox Indio driver. To acquire images and use the other functionality on the board, you must install both drivers.

You must also install the Intel i210 network controller driver (if it is not already installed) and configure it appropriately. Refer to MIL documentation for the location of this driver and required configuration information.

11. If you plan on acquiring images from a GigE Vision-compatible camera:
  - a. Disable active state power management (ASPM) for PCIe devices, to maximize the performance of Matrox Indio. In the BIOS, disable all ASPM (or equivalent) settings (typically accessible from the **Power management** sub-menu of the **Advanced Configurations** menu). In addition, if the operating system has an **ASPM for PCIe devices** option, disable this option as well. For example, under Microsoft Windows 7, open the **Power Options** dialog box from the Windows Control Panel. For the currently selected power plan, click on **Change Plan Settings** and then click on **Change Advanced Power Settings**. In the presented dialog, expand **PCI Express**, and then expand **Link State Power Management** and set it to **Off**.
  - b. Under Microsoft Windows, set the power plan option to high performance to maximize the performance of Matrox Indio. For example, under Microsoft Windows 7, open the **Power Options** dialog box from the Windows Control Panel and set the power plan option to **High Performance**.

## Connecting to peripheral devices over an Ethernet connection

You can connect Matrox Indio to your local area network (LAN) to receive data from or send data to, for example, a GigE Vision-compatible camera, a robot controller, or a device (such as a PLC) that communicates using the PROFINET, EtherNet/IP, or Modbus industrial protocol.

Matrox Indio can gain access to your LAN via Gigabit Ethernet (1000 BaseT), Fast Ethernet (100 BaseT), or Twisted Pair Ethernet (10 BaseT) through the Gigabit Ethernet connector.

### Required cabling for Ethernet connections

To make the connection, use an appropriate network cable. The required type of network cable depends on the type of connection:

Connection	Minimum category for network cable
Gigabit Ethernet	Category 5e (CAT5e) cable
Fast Ethernet (100 Mbits/sec)	Twisted Pair Category 5 (UTP5) cable
10 Mbits/sec	UTP5/UTP3 cable

An RJ45 connector (shown below) must be attached to one end of the cable.



Note that for optimal performance in the case of a GigE Vision-compatible camera, connect the camera directly to Matrox Indio, instead of using a router or network switch in between (although supported). To acquire images from multiple cameras and ensure that you don't drop frames, you can install and use multiple Matrox Indio boards in one computer. See *Chapter 3: Using multiple Matrox Indio boards* for information. If performance is not an issue and you use a router or network switch, refer to the *Matrox GigE Vision driver* chapter in the *MIL Hardware-specific Notes* of MIL documentation (or equivalent chapter in the documentation accompanying your Matrox Indio software) for the number of cameras from which a single Matrox Indio can simultaneously capture video.

### **Using a PoE device with your Matrox Indio board**

The Gigabit Ethernet network interface has built-in power over Ethernet (PoE) support. By default, when a PoE-capable device is detected, Matrox Indio provides a connected PoE device +48 V<sub>dc</sub> of power, for a maximum load of 15.40 Watts. This power source is electrically isolated from the rest of your computer. To provide power, Matrox Indio must be installed in a PCIe slot that meets the electrical requirements detailed in the *Electrical specifications* section, in *Appendix B: Technical information*.

### **Network connections for Industrial communications**

To communicate using an Ethernet industrial protocol (such as PROFINET), you must enable the service on your computer using the MILConfig utility's Communication item.

In addition, to communicate in a slave configuration with a controller that uses an Ethernet industrial protocol, you should assign the network interface a static IP address. To do so, refer to your operating system's documentation.

## Connecting to the auxiliary I/O interface

The Matrox Indio board has an auxiliary I/O interface composed of 16 optically isolated auxiliary signals that support sinking and sourcing configurations. 8 are inputs that receive up to 24 V, and 8 are outputs that support up to 24 V. For TTL-compatible voltages on output and for sensing at TTL-logic levels on input, you must adjust your board's jumper settings (discussed later).

Note that sinking and sourcing concepts refer to the *conventional current flow*, which means current flows from the positive potential towards the negative potential. A sinking device provides a path to *sink* current towards ground or to the *return path*; a sinking device does not provide power. A sourcing device provides a path that sources current; it provides a path from the power source. In the following diagram, the device on the right is the sourcing device, and the device on the left is the sinking device.

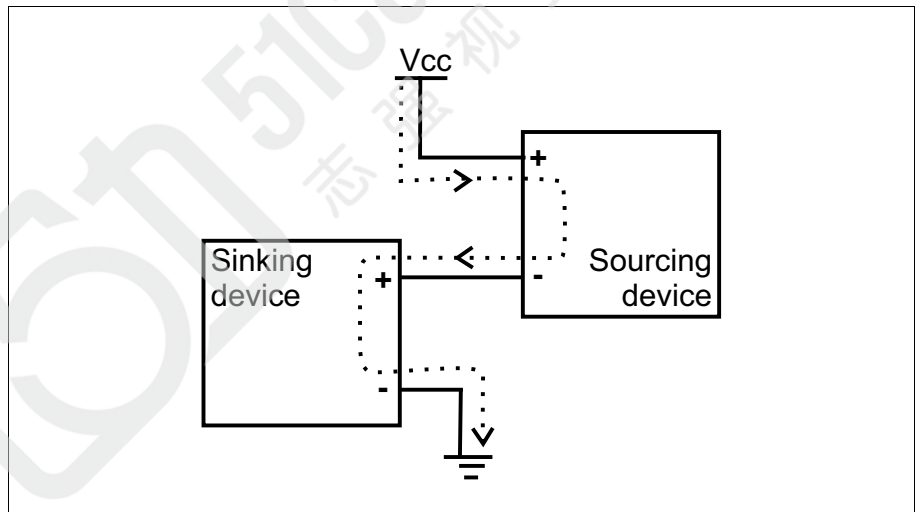

Equivalent circuit only

### Connecting devices to the auxiliary output signals

Matrox Indio auxiliary output signals can be interfaced with input modules (both NPN and PNP) found on most programmable logic controllers (PLCs) and other devices. The auxiliary output signals can also be interfaced with inductive load devices (such as a relay or a small motor) and TTL devices.

The Matrox Indio auxiliary output signals are NPN open-collector output signals. Unless in TTL mode<sup>1</sup>, they need to be connected to an external power source or a sourcing device because on their own, they are not capable of providing voltage to drive a device. When an auxiliary output signal is **on**, the circuit between its AUX\_OUT+ and AUX\_OUT- pins is closed, allowing current to flow from the AUX\_OUT+ pin to the AUX\_OUT- pin, if the AUX\_OUT+ pin is attached to a power source or a sourcing device. When an auxiliary output signal is **off**, the circuit between the AUX\_OUT+ and AUX\_OUT- pins of the signal is opened and no current flows through.

---

1. In TTL mode, when an output signal is **on**, pullup circuitry internally attached to the positive potential (AUX\_OUT+) sources the current. Connecting in this mode is discussed later in the *Connecting an auxiliary output signal to a TTL-compatible input* subsection of this section.



You can connect the auxiliary output signals in a sinking or sourcing configuration. The exact connection between the output signal, the connected device, and the power source depends entirely on the type of device to which you connect. You should essentially connect your device respecting the following:

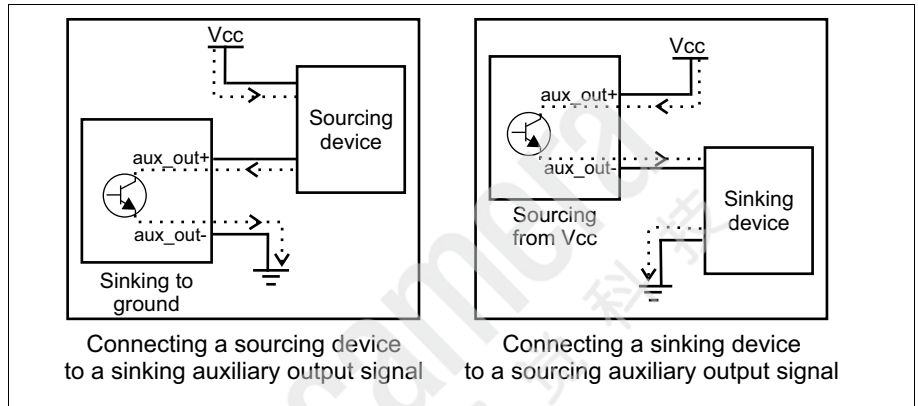

Equivalent circuit only

### **Important**

Notice that the power source must be provided externally; this is true unless in TTL mode (discussed later).

Depending on whether the auxiliary output signal is attached to a sourcing device or sinking device, the following can be observed:

Connection	Observed at	Observed voltage	
		Signal on (closed so current can flow from AUX_OUT+ to AUX_OUT- pin)	Signal off (open so current cannot flow from AUX_OUT+ pin to AUX_OUT- pin)
Sourcing device attached to AUX_OUT+ pin and return path attached to AUX_OUT- pin	AUX_OUT+ pin	Low	Floating <sup>1</sup> (voltage level is imposed by the sourcing device)
	AUX_OUT- pin	Low	Low
Power source attached to AUX_OUT+ pin and sinking device attached to AUX_OUT- pin	AUX_OUT+ pin	High	High
	AUX_OUT- pin	High	Floating <sup>1</sup> (voltage level is imposed by the sinking device)

1. Provided that the auxiliary output signal's on-board pullup circuitry is not instantiated. To instantiate the on-board pullup circuitry, you must install a jumper on pins 1-2 of the auxiliary signal's output mode connector.

**Connecting to a digital device that requires two predictable voltage levels to operate**

Therefore, the auxiliary output signals can only present one predictable voltage level for a given configuration: a low voltage level in a sinking configuration or a high voltage level in a sourcing configuration. Their other output state is, by default, floating. So, if you need to connect to a digital device that requires two predictable voltage levels to operate, pullup or pull-down circuitry must be added.

To simplify connectivity, Matrox Indio can instantiate pullup circuitry on-board with a resistor of 2.2 KOhms for each auxiliary output signal. To instantiate this pullup, you must install a jumper on pins 1-2 of the auxiliary signal's output mode connector.

To add pullup circuitry with different resistance or to add pull-down circuitry, attach an external pullup or pull-down resistor, respectively. A resistance value between 2 and 5 KOhms, inclusive, is suggested to protect your Matrox Indio board. Since your Matrox Indio auxiliary output signals can sink up to 100 mA, use the documentation of your input to calculate the required resistance for your external pullup/pull-down resistor (if necessary).

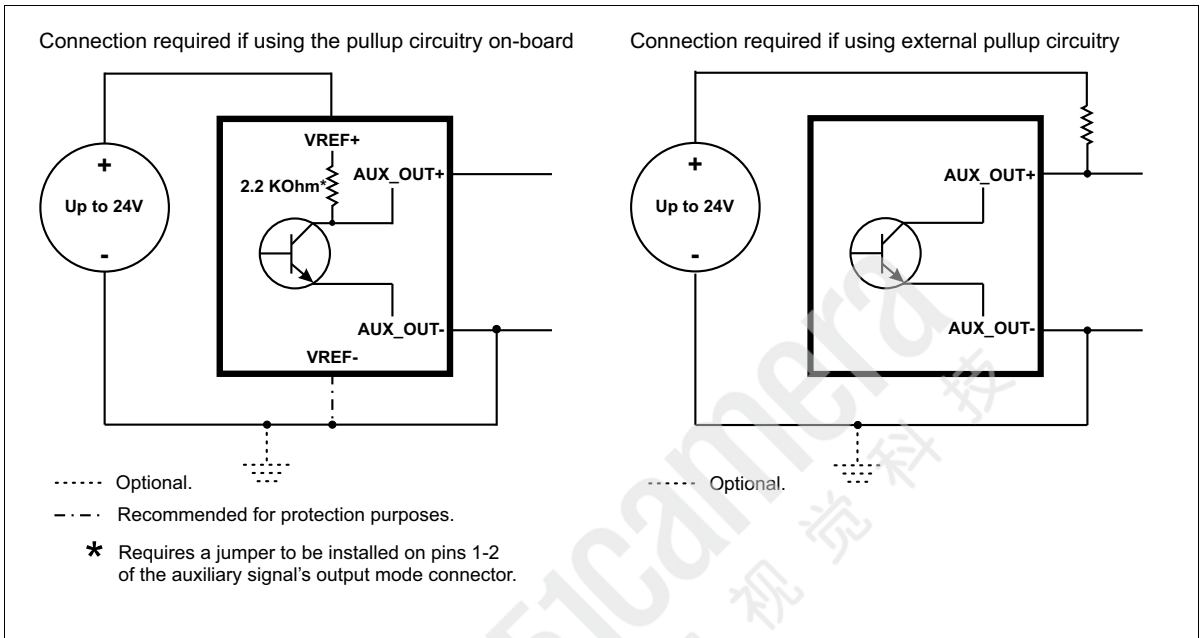

Equivalent circuit only

Note that in the connections above, the pullup circuitry causes an inversion if the input of the device is connected to the AUX\_OUT+ pin. When the auxiliary output signal is on, the circuit between its AUX\_OUT+ and AUX\_OUT- pins is closed, and current flows from the power source to the AUX\_OUT- pin. So the observed voltage at the AUX\_OUT+ pin will be low. Whereas, when the auxiliary output signal is off, the circuit between its AUX\_OUT+ and AUX\_OUT- pins is open, and current flows from the power source to the input of the device.

When instantiating the on-board pullup circuitry, the VREF- connection to the return path is not functionally required. The VREF- connection is only required for protection purposes against electrical faults; it acts as a return path for a bidirectional TVS diode between VREF+ and VREF-. Note that this is true also for the auxiliary input signals (discussed later).

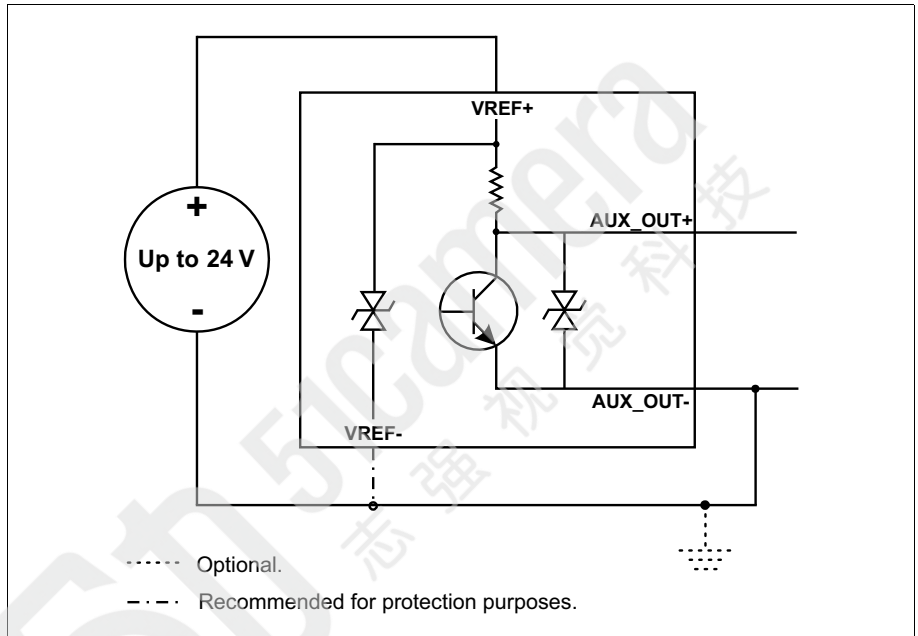

Equivalent circuit only

Before instantiating the on-board pullup circuitry, note that the auxiliary signals are grouped in two distinct banks of four inputs and four outputs each, and the signals in the same bank share the same VREF+ voltage reference. As such, if you instantiate the on-board pullup circuitry for multiple auxiliary output/input signals in the same bank, they will not be electrically isolated from each other. If you need them to be isolated from each other, you must use an external pullup resistor instead.

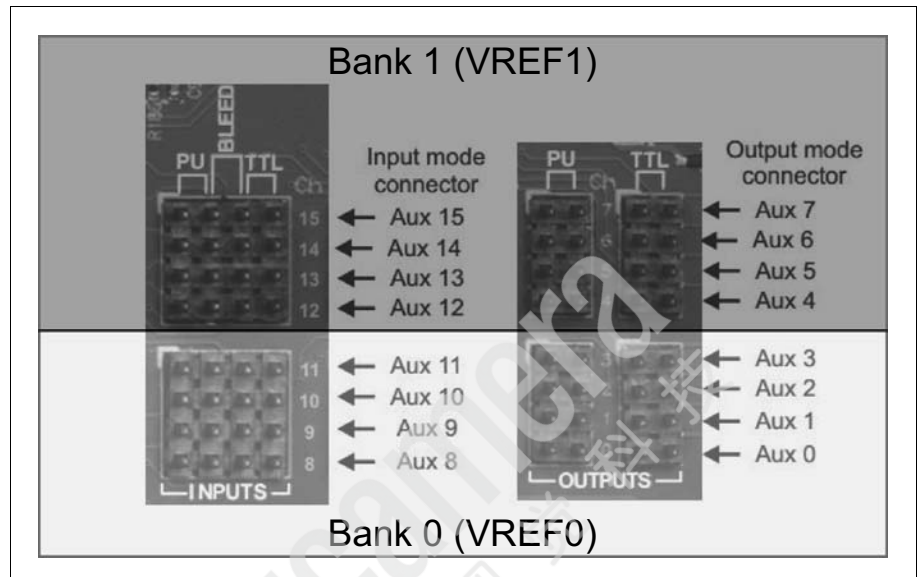

### **Warning**

The Matrox Indio auxiliary output signals are compatible with voltages up to 24 V. However, by default, the auxiliary output signals offer low resistance. When they are **on** (their circuit is closed), current flows directly through them. Ensure that the circuit created between the power source, the output signal, the connected device, and return path does not cause more than 100 mA to flow through the signal.

As a precaution, the auxiliary output signals are individually fuse-protected up to 100 mA. Matrox Indio uses resettable fuses. The fuses protect Matrox Indio if you accidentally connect their corresponding auxiliary output signal to a device that sources/sinks more current than Matrox Indio can safely transmit. If more than 100 mA of current, the fuse will eventually trip. After a few moments of disconnecting the device, the fuse will be reset.

The diagram below depicts Matrox Indio's on-board fuse.

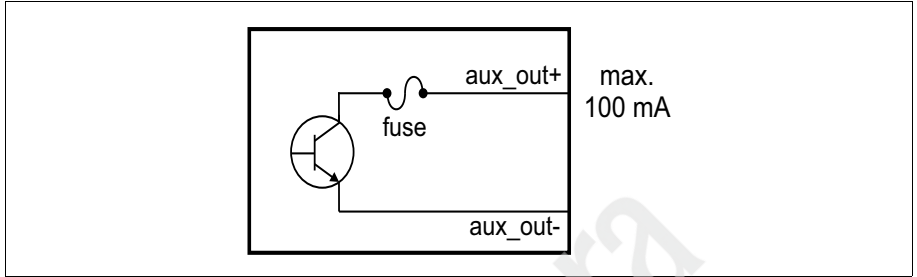

Equivalent circuit only

**About the connections in the following subsections**

The following subsections detail how to connect the most common third-party devices to the Matrox Indio auxiliary output signals. Note that Matrox Indio is grounded by being plugged into your computer, and its auxiliary output signals are optically isolated from the Host computer. So ground is only shown in the following subsections for reference, in case you need to reference your return path to ground for some other reason (for example, if you want to reference your return path to the chassis's ground).

To enable the on-board pullup for the auxiliary output signal, you must install a jumper on pins 1-2 of the auxiliary signal's output mode connector.

### Connecting an auxiliary output signal to a sinking input

Connect a Matrox Indio auxiliary output signal to a sinking input, as shown below.

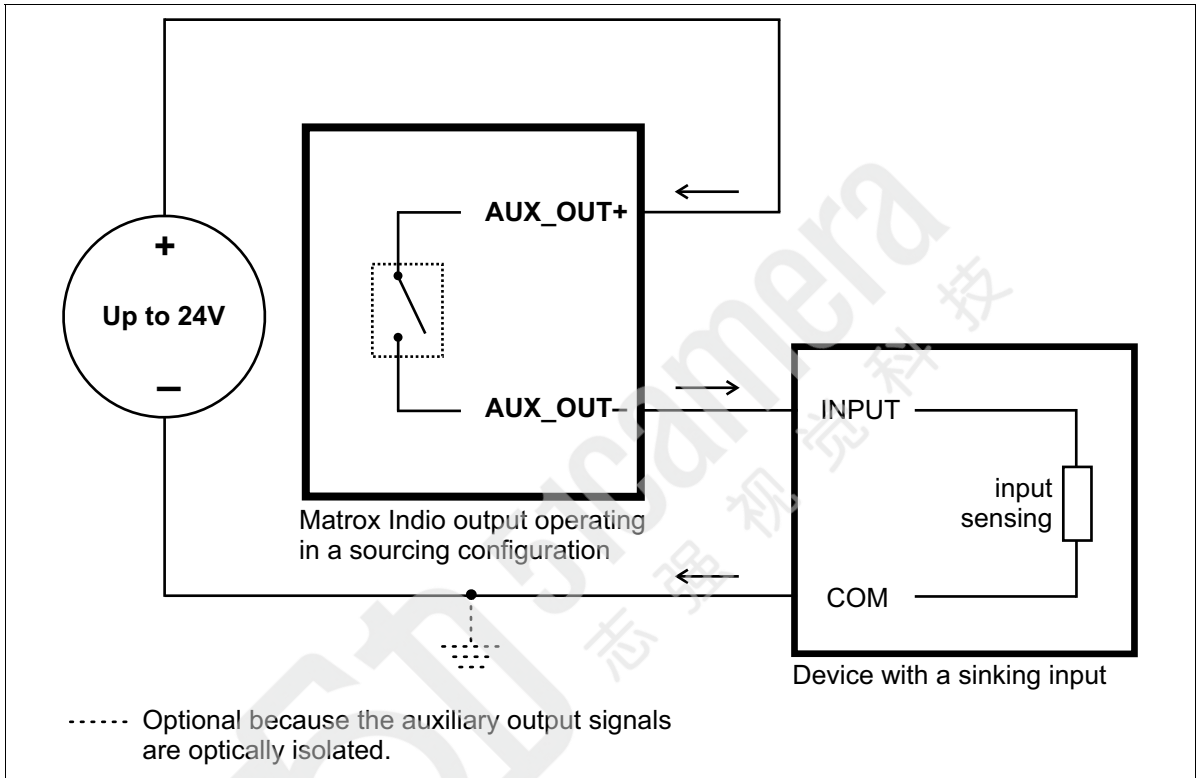

Equivalent circuit only

Note that, when connecting a resistive load sinking device instead of an input sensing sinking device, the same connection would be used as displayed above.

### Connecting an auxiliary output signal to a sourcing input

Connect a Matrox Indio auxiliary output signal to a sourcing input, as shown below.

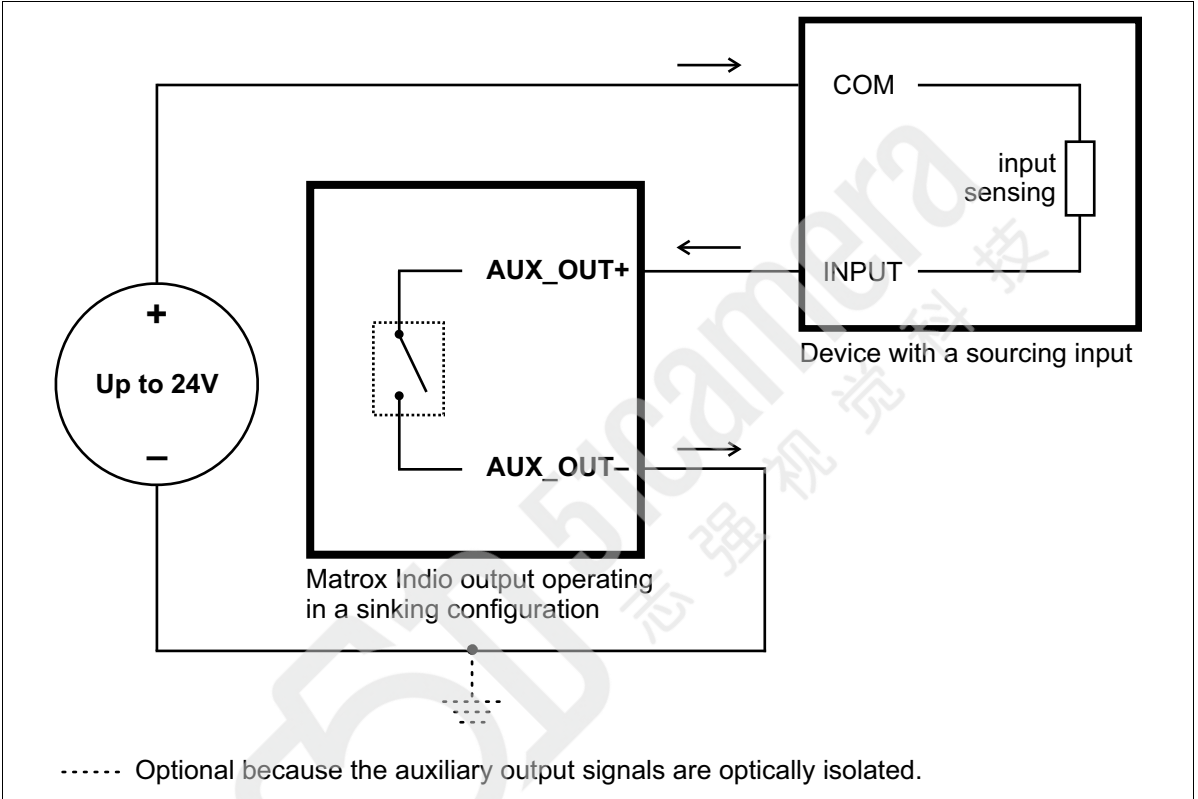

Equivalent circuit only

Note that, when connecting a resistive load sourcing device instead of an input sensing sourcing device, the same connection would be used as displayed above.



**Connecting an auxiliary output signal to an inductive load input**

Connect a Matrox Indio auxiliary output signal to an inductive load input, as shown below.

An inductive load device, such as a traditional relay, requires that you use a flyback diode to protect Matrox Indio from over and under-voltage, as shown below. This diode should be connected as close as possible to the input and voltage source of your inductive load device.

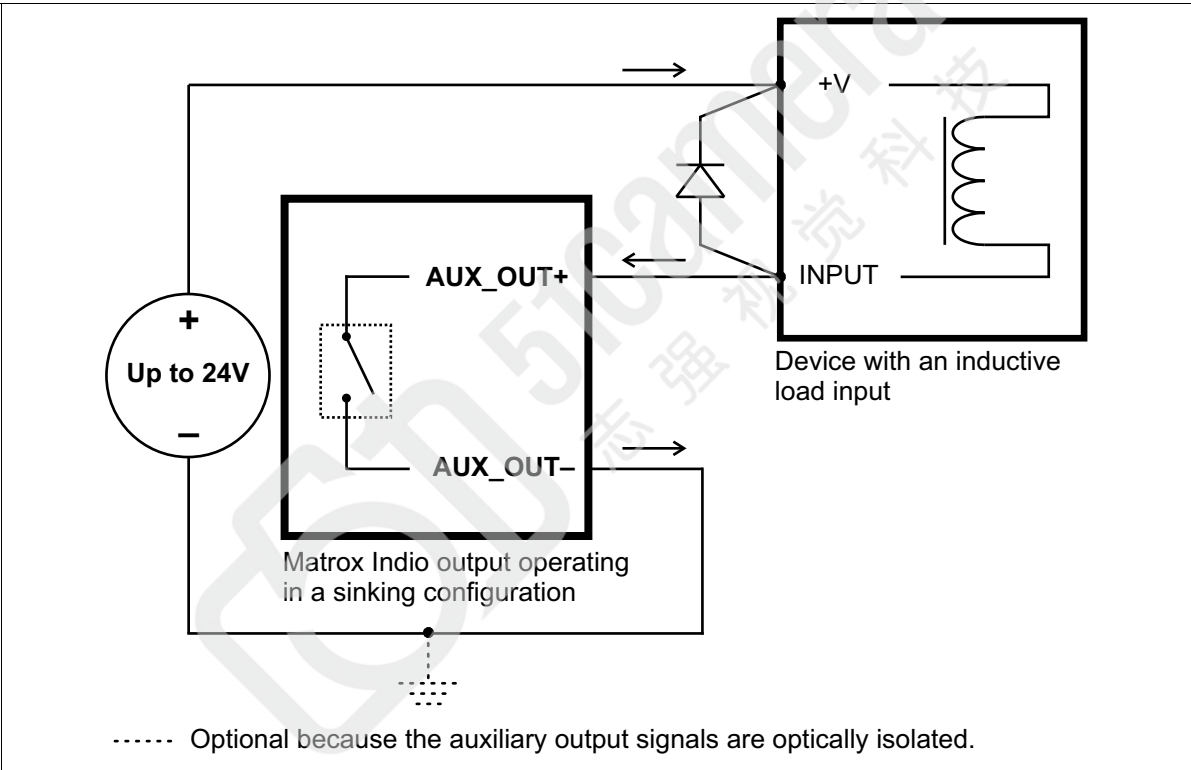

Equivalent circuit only

### Connecting an auxiliary output signal to a TTL-compatible input

Connect a Matrox Indio auxiliary output signal to a TTL-compatible input, as shown below.

In this configuration, TTL output mode must be enabled. To do so, you must install a jumper on pins 3-4 of the auxiliary signal's output mode connector; for information, refer to the *Input and output mode connectors* subsection of the *Matrox Indio connectors* section, in *Appendix B: Technical information*. In addition, you must externally connect the TTL\_COM pin of the auxiliary I/O connector to both the AUX\_OUT- pin of the auxiliary output signal and the return path pin of the input. Note that the return path pin is often labeled GND.

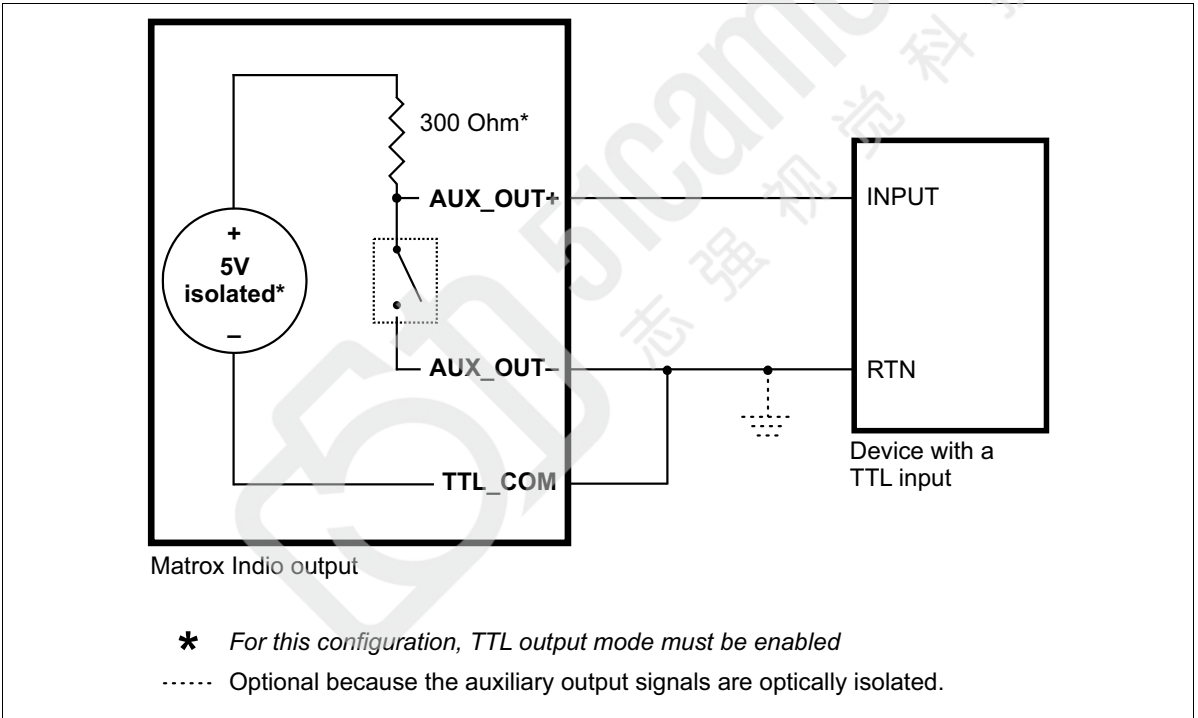

Equivalent circuit only

Before enabling TTL output mode, you should note that the auxiliary output signals in TTL mode share the same 5V supply (Matrox Indio generates an isolated 5 V supply) and TTL\_COM return path; this means that auxiliary output signals in this mode are not isolated from each other.

### ***Important***

Notice that power is provided through a pullup internally attached to the positive potential (AUX\_OUT+), and that even in TTL mode, the on/off circuitry is between the AUX\_OUT+ and AUX\_OUT- pins. This means that when the auxiliary output signal is **on**, the circuit between its AUX\_OUT+ and AUX\_OUT- pins is closed, and current flows from the internal power source to the AUX\_OUT- pin. So the observed voltage at the AUX\_OUT+ pin will be low. Whereas, when the auxiliary output signal is **off**, the circuit between its AUX\_OUT+ and AUX\_OUT- pins is open, and current flows from the internal power source to the AUX\_OUT+ pin. So the observed voltage at the AUX\_OUT+ pin will be high. That is, when the auxiliary output signal is **off**, the TTL input is high, and when the auxiliary output signal is **on**, the TTL input is low.

### Connecting devices to the auxiliary input signals

Matrox Indio auxiliary input signals can be interfaced with a wide variety of devices (such as proximity detectors). The Matrox Indio auxiliary input signals only detect when current flows from their AUX\_IN+ pin to their AUX\_IN- pin. As such, an auxiliary input signal must be connected to a device that controls the flow of current. When current is detected, the signal is reported as **on**; otherwise, it is reported as **off**. In software, you can enable an interrupt to be generated the moment current is detected. For information on the electrical specifications of the **on** and **off** voltage levels, see the *Electrical specifications* section, in *Appendix B: Technical information*.

You can connect the auxiliary input signals in a sinking or sourcing configuration. The exact connection between the input signal, the connected device, and the power source depends entirely on the type of device to which you connect. You should essentially connect your device respecting the following:

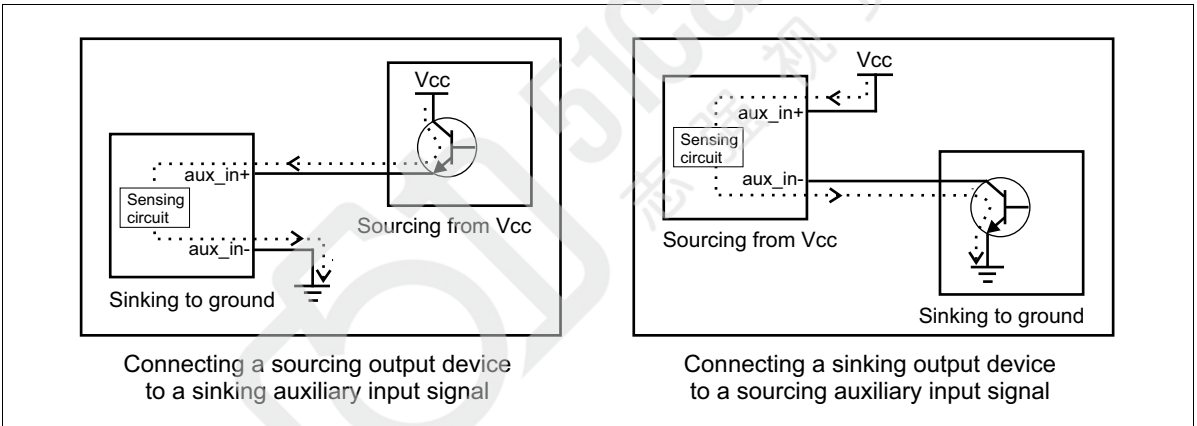

Equivalent circuit only

**Pullup circuitry**

In some cases, you must add pullup circuitry to connect an output device to an auxiliary input signal. Matrox Indio can instantiate pullup circuitry on-board with a resistor of 2.2 KOhms for each auxiliary input signal. To instantiate this pullup, you must install a jumper on pins 1-2 of the auxiliary signal's input mode connector. For different resistance, you must attach an external pullup resistor between the voltage source and the AUX\_IN+ pin.

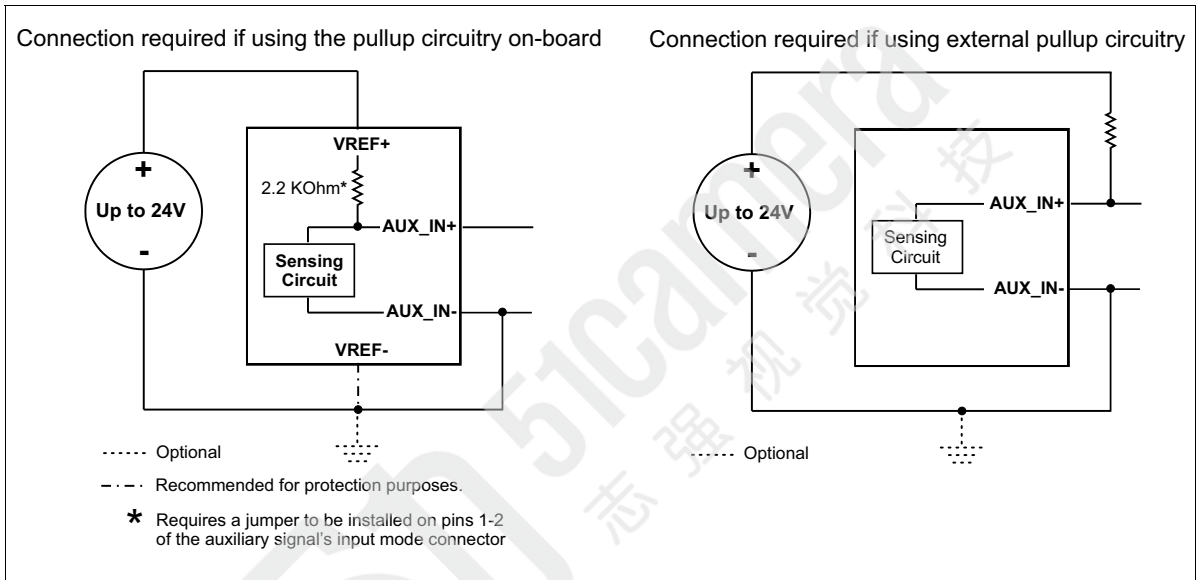

Equivalent circuit only

When instantiating the on-board pullup circuitry, the VREF- connection to the return path is not functionally required. The VREF- connection is only required for protection purposes against electrical faults; it acts as a return path for a bidirectional TVS diode between VREF+ and VREF-. Note that this is true also for the auxiliary output signals (discussed earlier).

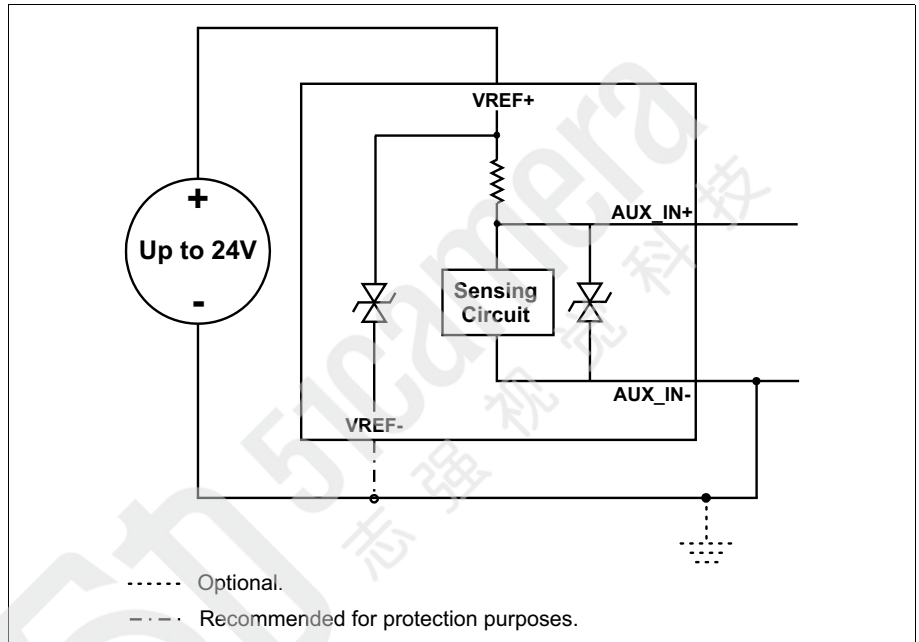

Equivalent circuit only

Before instantiating the on-board pullup circuitry, you should note that the auxiliary signals are grouped in two distinct banks of four inputs and four outputs each, and the signals in the same bank share the same VREF+ voltage reference. As such, if you instantiate the on-board pullup circuitry for multiple auxiliary output/input signals in the same bank, they will not be electrically isolated from each other. If you need them to be isolated from each other, you must use an external pullup resistor instead.

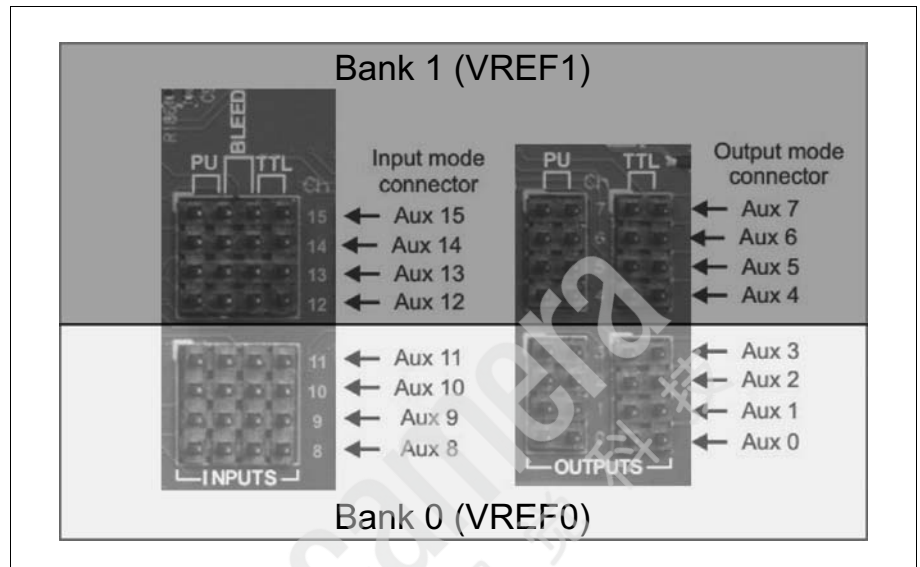

### Bleeder resistor

By default, if properly connected, current can't flow from the AUX\_IN+ pin (connected to a power source or a sourcing output device) to the AUX\_IN- pin, unless the connected output device closes the circuit. If the output device (for example, a two-wire proximity sensor) requires a small amount of current to still flow through to its other internal logic when the circuit is opened, a bleeder resistor is required.

To simplify connectivity, Matrox Indio can instantiate a bleeder resistor of 2.2 KOhms for each auxiliary input signal. To instantiate this bleeder resistor, you must install a jumper on pins 2-3 of the auxiliary signal's input mode connector. For different resistance, you must attach an external bleeder resistor between the AUX\_IN+ and AUX\_IN- pins.

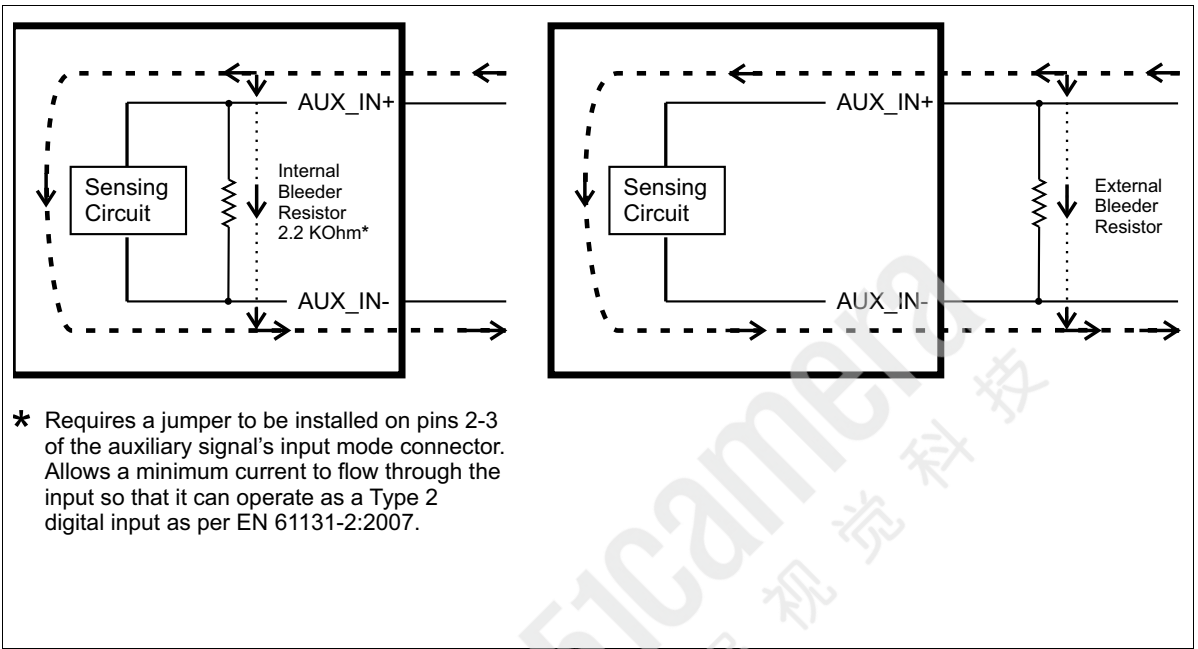

Equivalent circuit only

**About the connections in the following subsections**

The following subsections detail how to connect the most common third-party devices to the Matrox Indio auxiliary input signals.

Note that Matrox Indio is grounded by being plugged into your computer, and its auxiliary input signals are optically isolated from the Host computer. So ground is only shown in the following subsections for reference, in case you need to reference your return path to ground for some other reason (for example, if you want to reference your return path to the chassis's ground).



### Connecting a sourcing output to an auxiliary input signal

Connect a sourcing output to a Matrox Indio auxiliary input signal, as shown below.

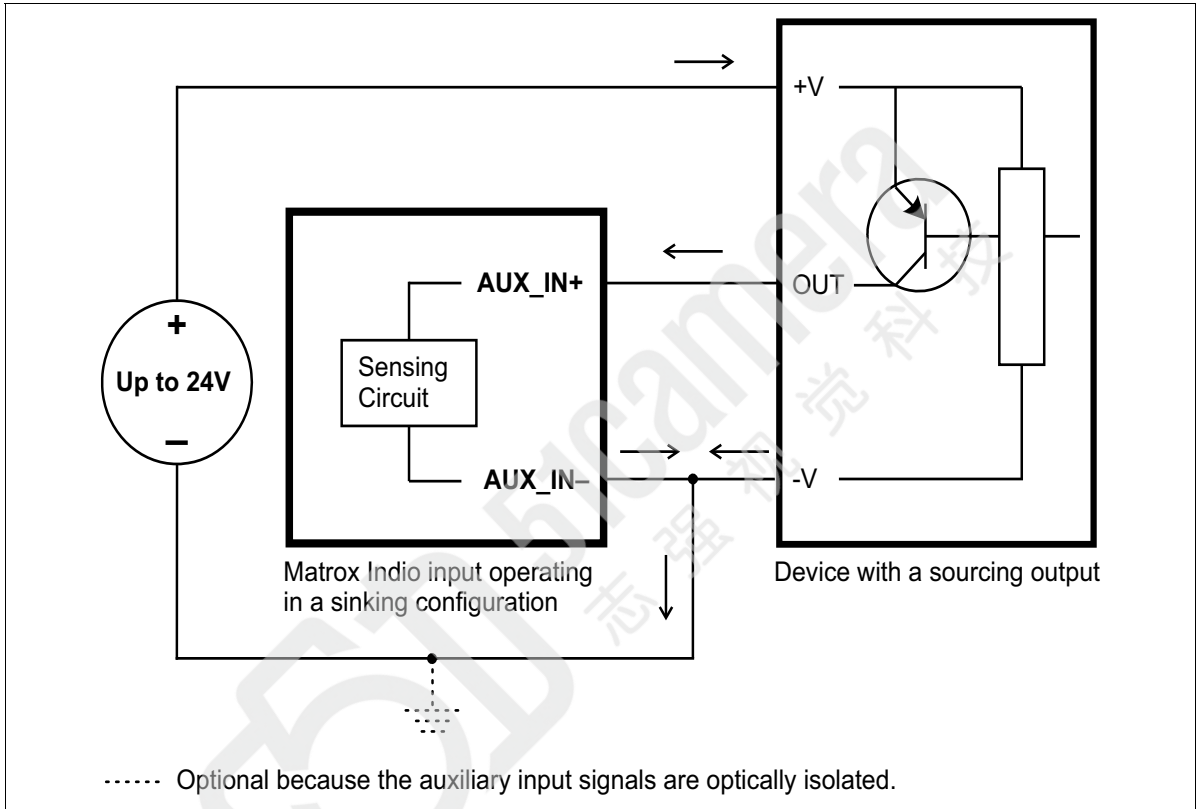

Equivalent circuit only

### Connecting a sinking output to an auxiliary input signal

Connect a sinking output to a Matrox Indio auxiliary input signal, as shown below.

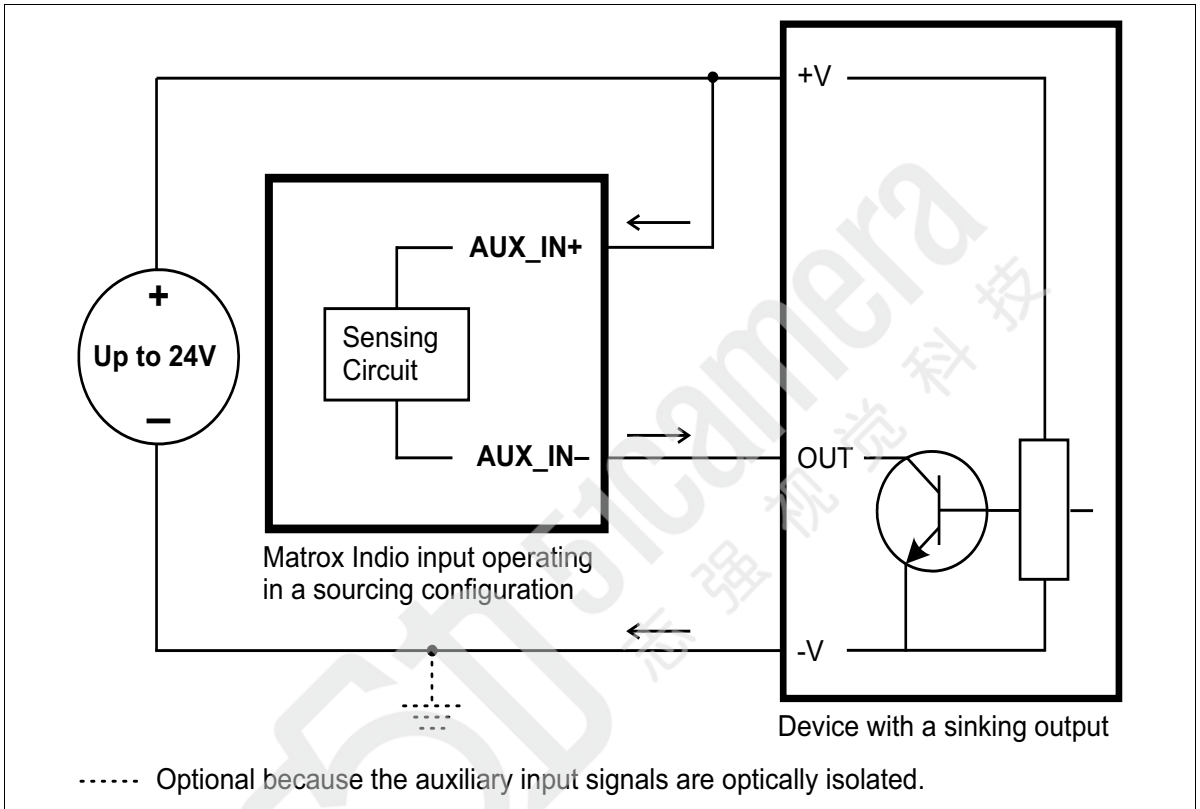

Equivalent circuit only

**Connecting a 3-wire PNP proximity sensor to an auxiliary input signal**

Connect a 3-wire PNP-compatible device to a Matrox Indio auxiliary input signal, as shown below.

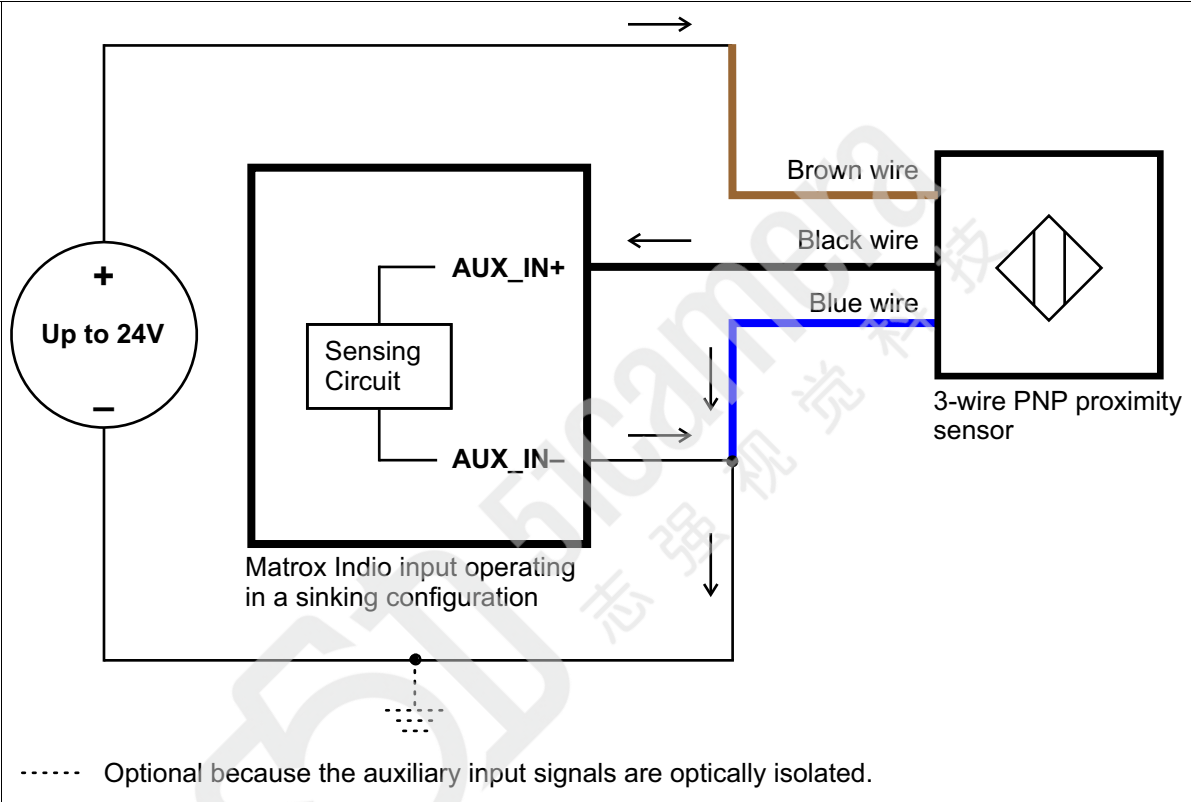

Equivalent circuit only

### Connecting a 3-wire NPN proximity sensor to an auxiliary input signal

Connect a 3-wire NPN-compatible device to a Matrox Indio auxiliary input signal, as shown below.

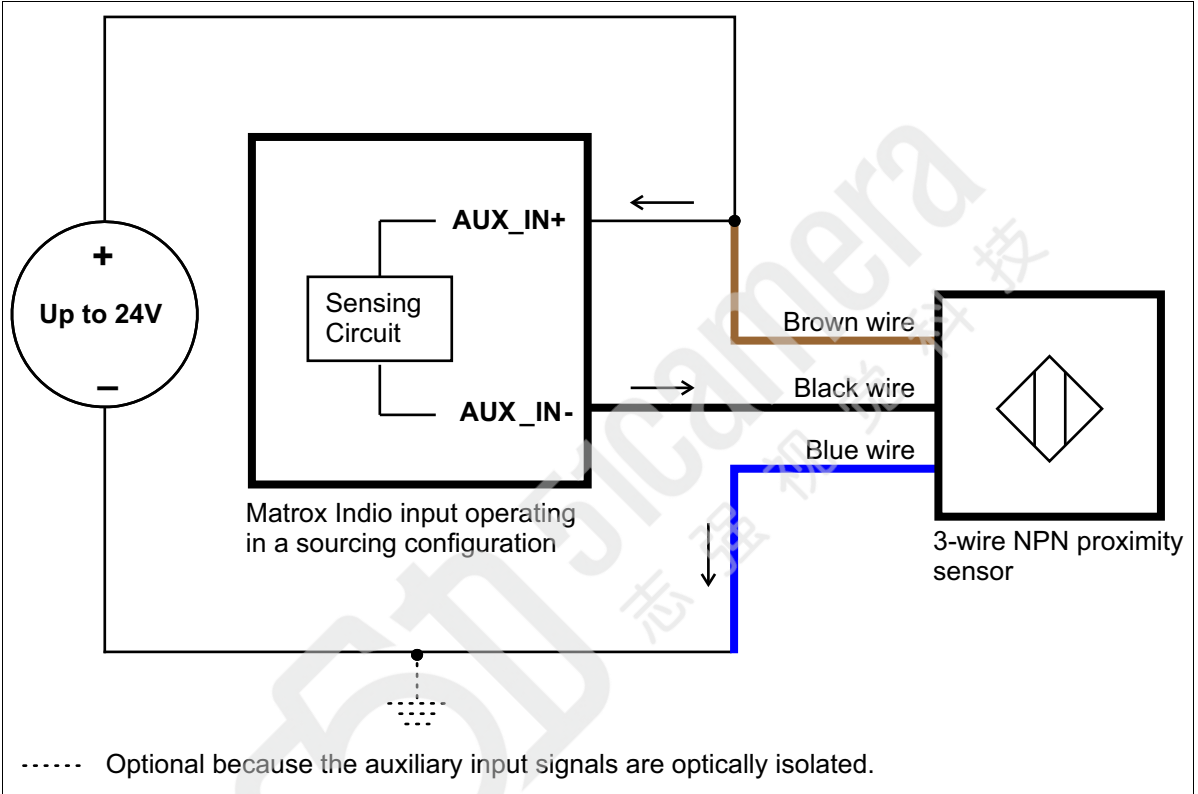

Equivalent circuit only

### Connecting a 2-wire proximity sensor to an auxiliary input signal

You can connect a 2-wire proximity sensor to a Matrox Indio auxiliary input signal in either a sourcing or sinking configuration (that is, on a positive or negative power wire). Note that in both cases, you will need to use the on-board 2.2 K $\Omega$  bleeder resistor or an external bleeder resistor, to ensure that a minimum amount of current flows into the proximity sensor in its on-state and in its off-state.

- For the auxiliary input signal to source the current (that is, to connect an auxiliary input signal on a positive power wire), connect the 2-wire device to the auxiliary input signal as shown below. To instantiate the on-board 2.2 K $\Omega$  bleeder resistor, you must install a jumper on pins 2-3 of the auxiliary signal's input mode connector. For different resistance, you must install an external bleeder resistor between the AUX\_IN+ pin and brown wire of the proximity sensor.

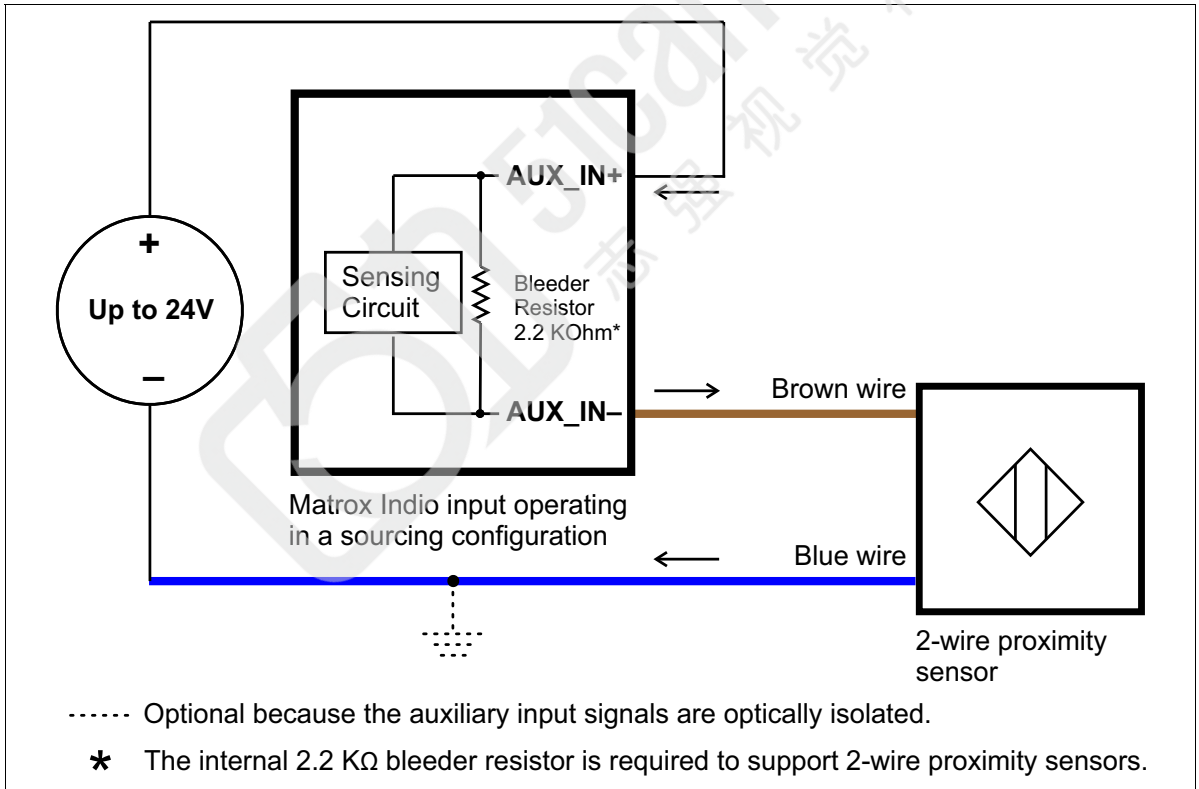

Equivalent circuit only

The bleeder resistor's value should guarantee that the minimal required current is provided to the connected sensor (the third-party device). For details regarding the sensor's minimum current requirements, refer to its documentation. Note that you should use a bleeder resistor with an appropriate power rating for your circuit.

- For the auxiliary input signal to sink the current, connect the 2-wire device to auxiliary input signal as shown below. To instantiate the on-board 2.2 K $\Omega$  bleeder resistor, you must install a jumper on pins 2-3 of the auxiliary signal's input mode connector. For different resistance, you must install an external bleeder resistor between the blue wire and the AUX\_IN- pin of the proximity sensor.

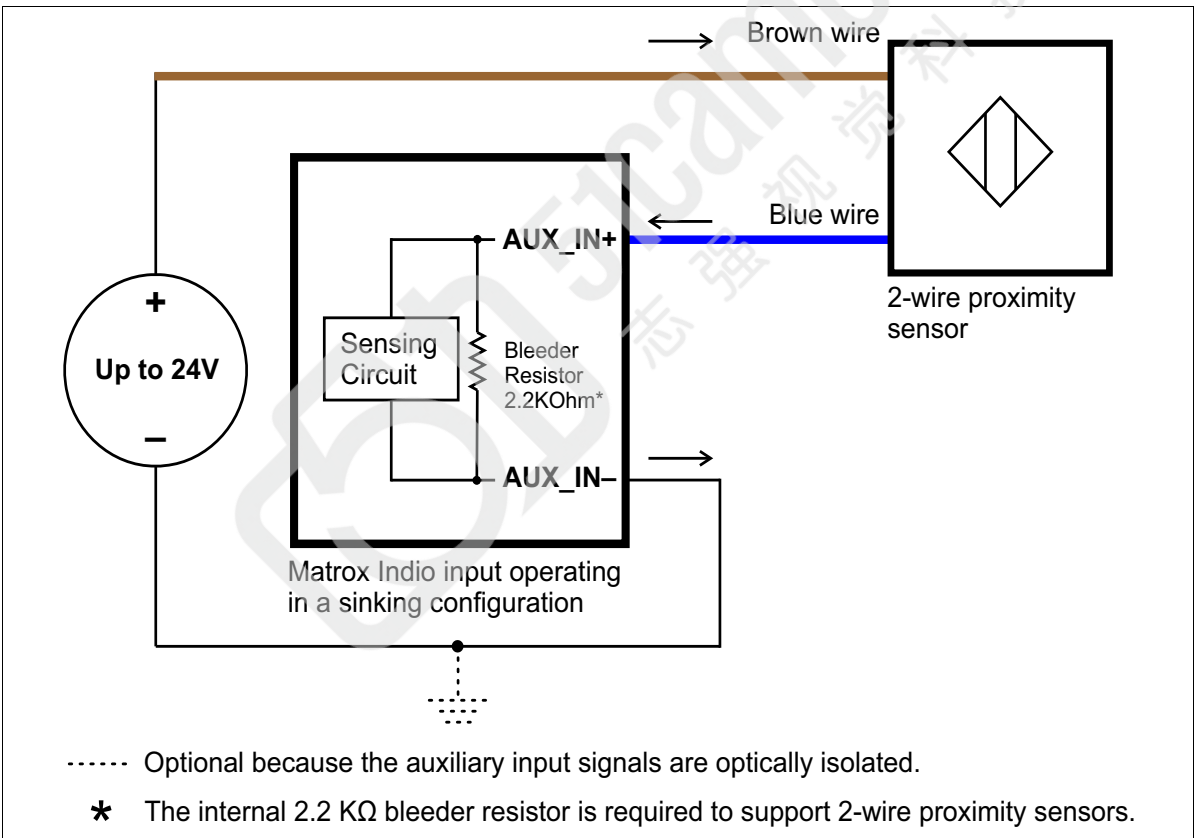

Equivalent circuit only

### Connecting a TTL-compatible output to an auxiliary input signal

Connect a TTL-compatible output to a Matrox Indio auxiliary input signal, as shown below. Note that the return path pin is often labeled GND.

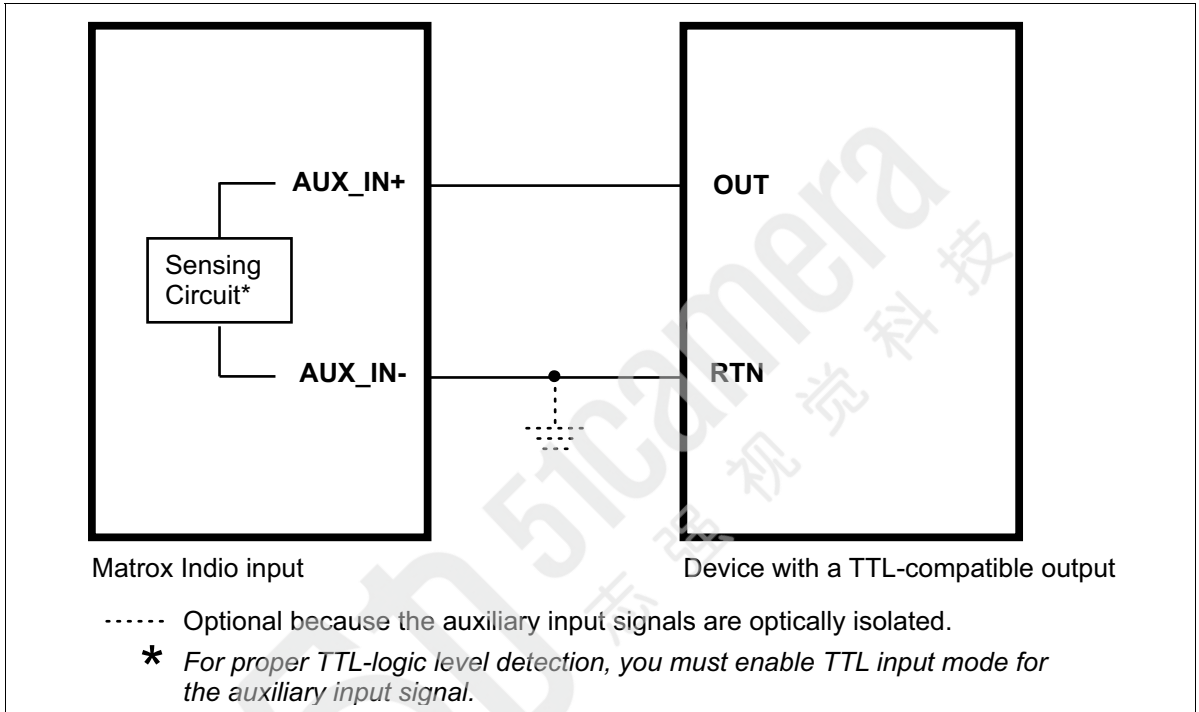

Equivalent circuit only

Note that in this configuration, you must enable TTL input mode for proper TTL-logic level detection. To enable this mode, you must install a jumper on pins 3-4 of the auxiliary signal's input mode connector. For information, refer to the *Input and output mode connectors* subsection of the *Matrox Indio connectors* section, in *Appendix B: Technical information*.





Chapter

# 3

## **Using multiple Matrox Indio boards**

This chapter explains how to use multiple Matrox Indio boards.

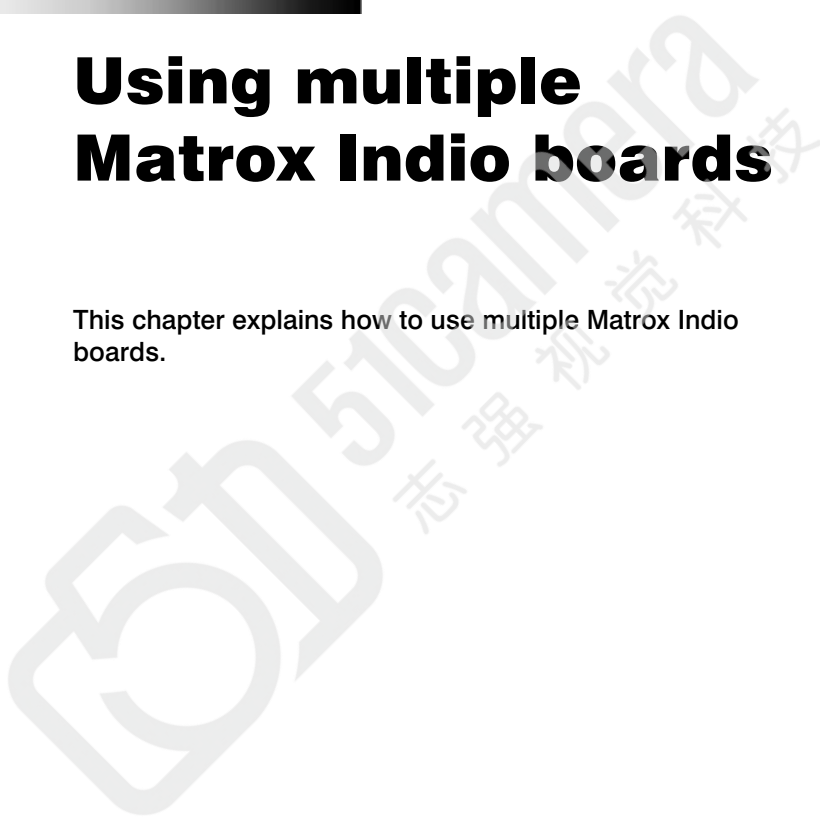

## Installation of multiple boards

---

You can install and use multiple Matrox Indio boards in one computer.

Install each additional Matrox Indio board as you installed the first board (refer to *Chapter 2: Hardware installation*). The number of Matrox Indio boards that you can install is primarily dependent on the number of physical slots in your computer, and your BIOS; your BIOS establishes how many PCIe devices can be mapped to the PCIe memory space of your computer.

Using MIL-Lite, you capture images from GigE Vision cameras, connected to different Matrox Indio boards, as you would capture images from cameras connected to a single Matrox Indio board. That is, you allocate a single Matrox GigE Vision system (`MsysAlloc` with `M_SYSTEM_GIGE_VISION`) and allocate a digitizer for each camera (network camera) that you want to use to capture images and/or access directly, using `MdigAlloc()`.

To access the other functionality on the Matrox Indio boards using MIL-Lite, you must allocate a MIL Matrox Indio system for each board (`MsysAlloc()` with `M_SYSTEM_INDIO`) and then allocate the resources of each MIL system.

## Simultaneous image capture from different boards

---

In addition to capturing images from multiple video sources with a single Matrox Indio board, you can also simultaneously capture images from video sources attached to multiple Matrox Indio boards.

Note that the number of video sources from which you can simultaneously capture images is limited by the Ethernet connection of each board. The use of a Gigabit Ethernet (1000 BaseT) connection will optimize the speed of data transmission from the connected cameras and will minimize data loss. In a Gigabit Ethernet (1000 BaseT) connection, each Matrox Indio board can sustain a maximum bandwidth of 1 Gigabits.

Chapter

# 4

## **Matrox Indio hardware reference**

This chapter describes the features of the Matrox Indio board, as well as the software that can be used with this board.

## Matrox Indio hardware reference

This chapter provides information on the Matrox Indio hardware. It covers the architecture, features, and modes of the board. A summary of the features of Matrox Indio, as well as pin assignments for the various connectors, can be found in *Appendix B: Technical information*.

The following diagram illustrates the data flow of the Matrox Indio board.

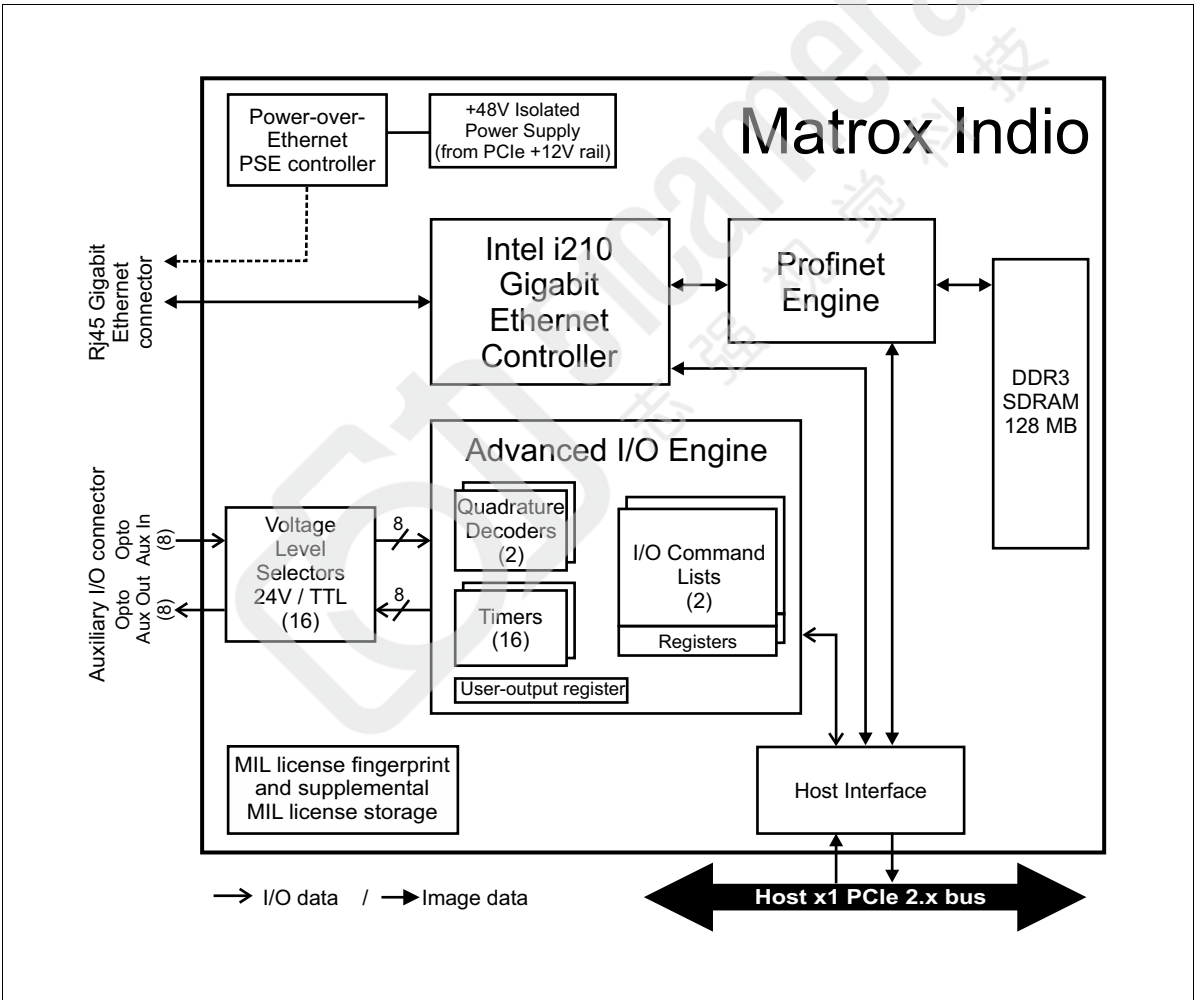

## Advanced I/O engine

---

Matrox Indio has an advanced I/O engine that controls the auxiliary I/O interface. The engine includes 16 timers, two rotary decoders, two I/O command lists (and their associated output registers), and an 8-bit user-output register.

### Auxiliary I/O interface

The auxiliary I/O interface is composed of 8 input and 8 output, optically isolated, digital auxiliary signals. The auxiliary input signals can trigger functionality in the advanced I/O engine (for example, timers), cause software events, or can be transmitted to third-party devices over an auxiliary output signal. Onto an auxiliary output signal, you can route a signal generated in the advanced I/O engine (for example, a timer output) or the state of a bit of one of the engine's registers (for example, the user-output register which is set using software). All auxiliary signals support voltages up to 24 V in sinking or sourcing configurations.

By default, an auxiliary input signal at 11 V or above is considered high, while anything at 5 V or below is considered low. However, by installing jumpers on the board, you can individually set auxiliary input signals to TTL mode. When an auxiliary input signal is in this mode, a signal at 2 V or above is considered high, while anything at 0.8 V or below is considered low; typically, the signal should have a maximum of 5 V and a minimum of 0 V.

Typically, for an auxiliary output signal to source voltage, you must attach an external power source to Matrox Indio. However, by installing jumpers on the board, you can individually set auxiliary output signals to TTL mode; in which case, they can source up to 5 V<sup>1</sup> without an external power source. For an auxiliary output signal configured in TTL mode, the signal will either output 5 V or 0 V. When you route an external signal to an auxiliary signal or vice versa, verify that the external signal meets the electrical specifications of the auxiliary signal. All auxiliary output signals are individually fuse-protected up to 100 mA.

Note that auxiliary output signals in TTL mode share the same 5V supply (Matrox Indio generates an isolated 5 V supply) and TTL\_COM return path; this means that auxiliary output signals in this mode are not isolated from each other (regardless of the bank).

---

1. Through an on-board 300 Ohm pullup circuit.

By installing jumpers on the board, you can also enable an on-board 2.2 KOhm pullup resistor or on-board bleeder resistor for an auxiliary input signal, and an on-board 2.2 KOhm pullup resistor for an auxiliary output signal. An on-board bleeder resistor is needed on input when interfacing with a 2-wire proximity sensor to ensure that there is minimal leakage current in the open state.

Note that the auxiliary signals are grouped in two distinct banks of four inputs and four outputs each. The signals in the same bank share the same VREF+ voltage reference. As such, if you instantiate the on-board pullup circuitry for multiple auxiliary output/input signals in the same bank, they will not be electrically isolated from each other. If you need them to be isolated from each other, you must use an external pullup resistor instead.

The opto-isolated auxiliary signals pass through an opto-coupler, a device that protects the board from outside surges and different ground levels, and allows the board to be isolated.

Each auxiliary signal has an associated status LED so that you can ensure correct behavior.

To configure the auxiliary signals, use the MIL-Lite `MsysControl()` function with the `M_IO...`, control types. To use an auxiliary input signal as a trigger source, use the `MsysControl()` or `MsysIoControl()` function with an `M_..._TRIGGER_SOURCE` control type. Your application can also act upon and interpret the state of an auxiliary input signal. To poll the state of an auxiliary input signal, use `MsysInquire()` with `M_IO_STATUS`. The state of an auxiliary input signal can also generate an interrupt; to do so, use `MsysControl()` with `M_IO_INTERRUPT_STATE` and then use `MsysHookFunction()` with `M_IO_CHANGE` to hook a function to this event (that is, to set up an event handler).

## Timers

Your Matrox Indio has 16 timers that can be used to coordinate events. Each timer can generate a timer output signal with one pulse (one low and one high segment) per cycle, either in continuous mode or triggered mode. In continuous mode, the timer starts to output a signal when it is enabled, and repeats the same cycle until the timer is disabled. In triggered mode, an enabled timer waits to receive a trigger signal, before it begins to output a signal with the specified delay and duration.

The timers can be triggered by an auxiliary input signal, the state of a bit of an I/O command list's output register, a rotary decoder output, another timer, or by software.

Each of the timers (Timer 1 through 16) is a 32-bit timer and can count up to 4,294,967,295 clock ticks before resetting. Each timer can use a specified clock source for its active period and a different specified clock source for its delay period. The clock sources can be selected from the following:

- **A clock that is internally generated.** Each timer can use your Matrox Indio board's clock generator, which can generate a single clock with a programmable period of up to 128 nsecs.
- **A clock from an external source.** In this case, you must define the appropriate auxiliary input signal as a timer-clock input; the timer-clock input signal must meet the electrical specification of the auxiliary signal.
- **A clock based on another timer output.** For example, Timer 1 can use a clock based on Timer 2, and Timer 2 can use a clock based on Timer 1.
- **A clock based on a rotary decoder's output.** In this case, the timer will act more as a counter because it is rare that a rotary decoder's output is periodic.

To route a timer output on an auxiliary signal, use the MIL-Lite function `MsysControl()` with `M_IO_SOURCE* + M_AUX_IOn` set to `M_TIMERm`. Set up the timers using `MsysControl()` with `M_TIMER_...`

### **Rotary decoders**

Matrox Indio features two rotary decoders (quadrature decoders). They are used to decode quadrature input received from a rotary encoder with quadrature output. A rotary encoder is a device that provides information about the position and direction of a rotating shaft (for example, that of a conveyor belt). The encoder outputs a two-bit code (also known as Gray code) on two wires for each change in position of the rotating shaft; for a given direction of the rotating shaft, the rotary encoder outputs the code in a precise sequence (either 00 - 01 - 11 - 10 or 00 - 10 - 11 - 01, depending on how the rotary encoder is attached to the rotating shaft). If the rotating shaft changes direction, the rotary encoder transmits the Gray code in the reverse sequence (00 - 10 - 11 - 01 or 00 - 01 - 11 - 10, respectively). The Matrox Indio rotary decoders can receive quadrature input along any two specified auxiliary input signals.

The rotary decoder supports encoder frequencies of up to 2 KHz.

Note that an external source must be used to power the rotary encoder (for example, your computer's 5 V power source).

You can configure the rotary decoder's settings, using the MIL-Lite function `MsysControl()` with `M_ROTARY_ENCODER...`

### **I/O command lists**

Matrox Indio has two I/O command lists, each of which allow you to schedule commands to change the state of a bit of an I/O command register at a specified time or counter value. You can route the state of the bit to an auxiliary output signal to control a connected device at a required moment; the state of the bits can be routed to any of the auxiliary output signals or can be used, for example, to trigger a timer. You can use an I/O command list, for example, when multiple parts are traveling between a sensor and one or more ejector(s) and you need to schedule the ejection/redirection of the different parts based on some analysis.

To offset the moment at which a command should occur, each I/O command list has 4 reference latches. Latches are used to store a timestamp or counter value upon the specified transition of a specified signal. You can then use this timestamp or counter value to schedule commands relative to this event.



You can add the following commands to an I/O command list:

Command	Description
Cause a rising edge	Changes the specified bit such that the associated signal will transition from low to high, if it is low.
Cause a falling edge	Changes the specified bit such that the associated signal will transition from high to low, if it is high.
Cause an active high pulse	This command adds a rising edge command followed by a falling edge command a specified duration afterwards.
Cause an active low pulse	This command adds a falling edge command followed by a rising edge command a specified duration afterwards.
Cause a very short active high pulse	Unlike a regular active high pulse command, a single command producing the shortest possible pulse is added to the list.

You can configure the I/O command lists, using the MIL-Lite `MsysIo...()` functions. Refer to MIL documentation for more information on I/O command lists.

### User-output register

Matrox Indio has an 8-bit user-output register. This register allows you to manually set the state of an auxiliary output signal to transmit application-specific user output (for example, to start or stop an external process based on some calculation or analysis). You can enable the routing of a user-output register bit to its corresponding auxiliary output signal. Then, when the bit is on, the circuit of the auxiliary output signal is closed and the current flows through; when the bit is off, the circuit of the signal is open (the output can be pulled high by installing a jumper). Each bit is referred to as a user-bit. To enable the routing of a user-output register bit to its corresponding auxiliary output signal, use the MIL-Lite function `MsysControl()` with `M_IO_SOURCE` and `M_USER_BITn`; to set the state of a user-bit, use `MsysControl()` with `M_USER_BIT_STATE`.

## Communication over Ethernet

---

Matrox Indio has a Gigabit Ethernet network interface that has built-in power over Ethernet (PoE) support. The interface is controlled using the Intel i210 Gigabit Ethernet controller.

Although you can use the network interface for general purpose, Gigabit network communication, the interface is intended for grabbing from a GigE Vision-compatible camera<sup>1</sup>, or for communicating with external devices (for example, a PLC) using the PROFINET, EtherNet/IP, or Modbus industrial protocol. For communication using the PROFINET protocol, Matrox Indio has a PROFINET engine; if the engine is enabled (using MILConfig), it provides a hardware-assisted PROFINET interface that supports a minimum I/O cycle time of 1 msec, as opposed to the software-only PROFINET interface that supports a minimum I/O cycle time of 16 msec.

When communicating with an external device using an industrial protocol and your process relies on a specific response time, it is not recommended to use the network interface also for grabbing or general network traffic, unless using the hardware-assisted PROFINET interface. The LAN connection associated with the hardware-assisted PROFINET interface can be shared with other Ethernet traffic. This is possible because the LAN connection, used to allow PROFINET communication to occur, will instantiate a second Ethernet communication device with its own MAC and IP settings; these settings are distinct from those of the main Ethernet communication interface, available generally to the operating system. The two Ethernet communication channels can be represented as follows.

- 
1. Unlike when using other Matrox imaging boards, image acquisition with Matrox Indio is made possible because the operating system recognizes the GigE Ethernet network interface as another network port. So when you allocate a MIL GigE Vision system (using MIL or one of its derivatives), you can grab from GigE Vision-compatible devices connected to the Gigabit Ethernet network interface. For all other functionality on the board, you must allocate a MIL Matrox Indio system. Matrox Capture Assistant can allocate and interface with a MIL GigE Vision system, and not with a MIL Matrox Indio system. Refer to MIL documentation for more information.

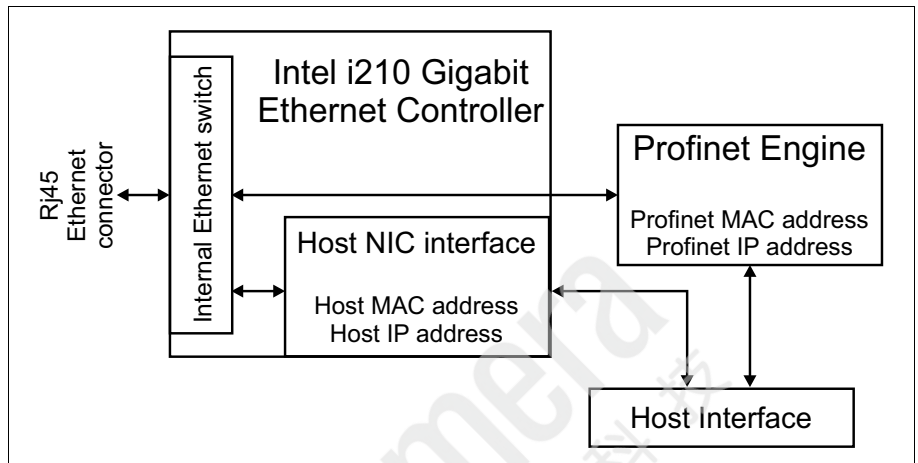

To grab from a GigE Vision-compatible camera, you must install the Intel i210 network controller driver (if it is not already installed) and configure it appropriately. Refer to MIL documentation for the location of this driver and required configuration information (for example, how to enable jumbo packets and select optimal settings for the interrupt throttling rate and number of receive buffers). Note that if you want to use the interface for general network traffic, you must also install the driver.

Matrox Indio comes equipped with an auto medium-dependent interface crossover port (MDIX) that can operate at all link speeds (10, 100, and 1000 Mbits/sec). A MDIX port simplifies setup by automatically detecting and using the appropriate connection type, eliminating the need for cross-over cables.

### **Power-over-Ethernet**

Matrox Indio supports both power-over-Ethernet (PoE) compliant devices and non-PoE devices; Matrox Indio automatically detects whether the device is PoE-compliant.

When a PoE compliant device is detected, Matrox Indio provides the device +48 V<sub>dc</sub> of power, for a maximum load of 15.40 W, provided that Matrox Indio is installed in a PCIe slot that meets the electrical requirements detailed in the *Electrical specifications* section.

This power source is electrically isolated from the rest of your computer.

When connecting to non-PoE compliant devices, Matrox Indio has appropriate circuitry to ensure that no power is transmitted.

Matrox Indio is also equipped with an over-current protection mechanism and a resettable fuse that can sustain a current of 750 mA.

### **Data transfer**

---

Matrox Indio is a x1 PCIe 2.0 board, so it can transfer data over any PCIe slot. Under optimum conditions, Matrox Indio can exchange data with the Host at a peak transfer rate of up to 500 Mbytes/sec if the board is installed in a PCIe 2.0 slot.

# **Appendix A: Glossary**

This appendix defines some of the specialized terms used in the Matrox Indio documentation.

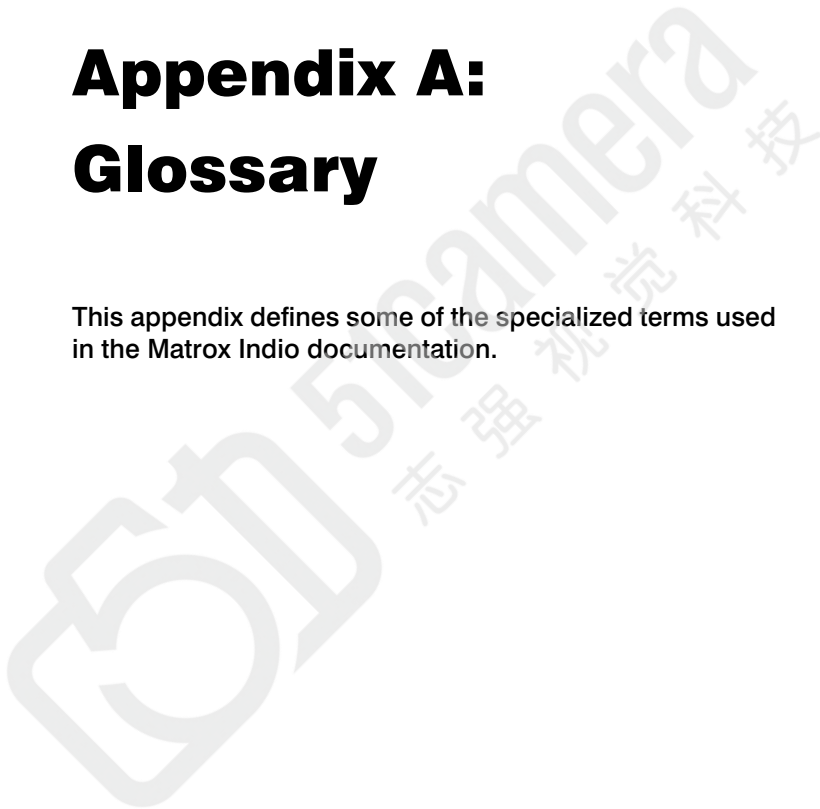

## Glossary

---

- **Auxiliary I/O.**

*Auxiliary input/output.* Non-video digital signals that can support one or more functionalities depending on the auxiliary signal (for example, trigger input or timer output).

- **Bandwidth.**

A term describing the capacity to transfer data. Greater bandwidth is needed to sustain a higher transfer rate. Greater bandwidth can be achieved, for example, by using a wider bus or by increasing the clock frequency at which an interface or a processing core operates (for example, increasing the DDR3 SDRAM clock frequency).

- **DDR3 SDRAM.**

*Double-data-rate type 3 synchronous dynamic random-access memory.* A type of general purpose consumer RAM. DDR3 SDRAM allows for data transfer at very high speeds, which is important for I/O-bound functions. This type of memory is inexpensive, high density, and very efficient as long as the data is accessed contiguously.

- **Latency.**

The time from when a command is sent to when its operation is started.

- **PCIe.**

*Peripheral Component Interconnect Express.* The standard used for the computer bus that acts as an interface between hardware devices, such as Matrox Indio, and your computer.

- **Payload.**

The amount of data transmitted to the PCIe bus within each data packet. PCIe supports payload sizes of 128, 256, 512, 1024, 2048, and 4096 bytes.

- **Rotary encoder.**

A device used to convert the angular position of a shaft or axle to a digital code.

- **Sinking device**

Device providing a path to sink current towards the negative power line source (-).

- **Sourcing device**

Device providing a path to source current from the positive power line source (+).

- **Timer output.**

The signal generated by one of the timers. The timer output can be used to control external hardware. For example, it can be fed over an auxiliary signal to the video source to control its exposure time or can be used to fire a strobe light.

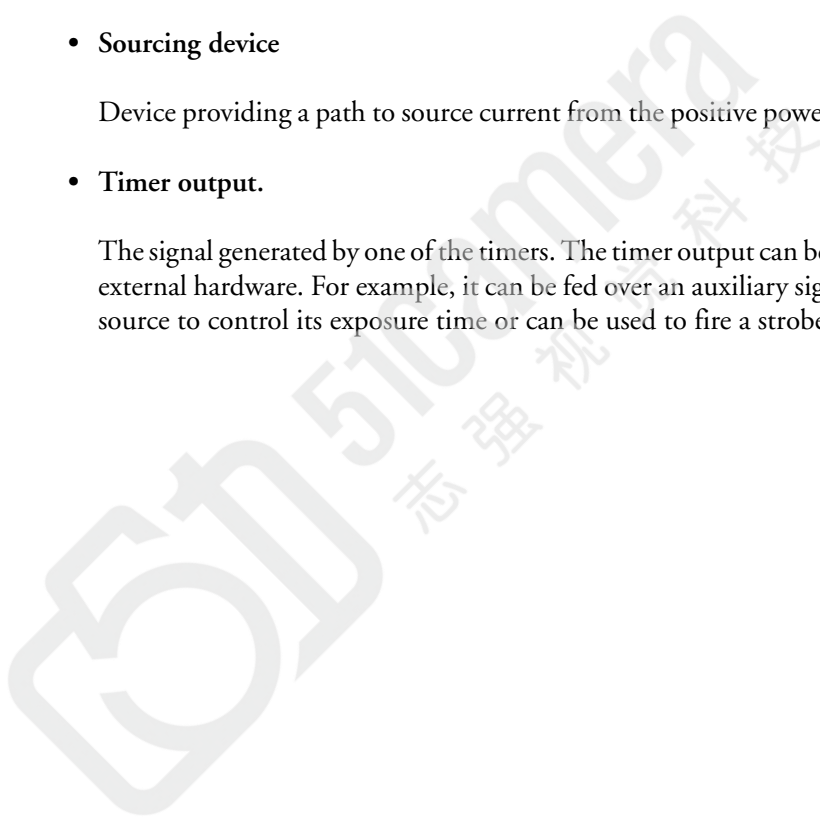





# **Appendix B: Technical information**

This appendix contains information that might be useful when installing your Matrox Indio.

## Board summary

---

### Global information

- Operating system: Microsoft Windows or Linux.
- Minimum computer requirements:
  - Any PCIe Gen 1 or Gen 2 slot (x1, x4, x8, x16).
  - Processor with an Intel 32-bit or 64-bit architecture, or equivalent.
  - A relatively up-to-date PCIe computer; one that supports the PCIe Gen 2 standard is preferable. The list of platforms that are known to be compatible with Matrox Indio is available on the Matrox website, under the board's PC compatibility list.
  - A proper power supply. Refer to the *Electrical specifications* section.

### Technical features

- x1 PCIe 2.0 Host interface.
- An advanced I/O engine that includes the following.
  - 16 independent, opto-isolated, digital auxiliary signals (8 inputs and 8 outputs).
    - › Each auxiliary signal can sink or source up to 24 V. To source more than 5 V, you must attach an auxiliary power source to Matrox Indio. All auxiliary output signals are individually protected up to 100 mA with a resettable fuse.
    - › Jumper-selectable support for TTL mode for each auxiliary input and output signal (pullup resistor with isolated +5 V supply for output signals).

- › Jumper-selectable support for an on-board 2.2 KOhm pullup resistor or on-board bleeder resistor for each auxiliary input signal and an on-board 2.2 KOhm pullup resistor for each auxiliary output signal. An on-board bleeder resistor is needed on input when interfacing with a 2-wire proximity sensor to ensure minimal leakage current in the open state.
- › Auxiliary input signals have interrupt-generation capabilities.
- 16 timers.
- Two rotary decoders that support input from rotary encoders with quadrature output.
- Two I/O command lists (used to schedule I/O commands in any order).
- One 8-bit user-output register.
- Gigabit Ethernet network interface that has built-in power over Ethernet (PoE) support. The interface is controlled using the Intel i210 Gigabit Ethernet controller.
  - Communication support with external devices using the PROFINET, EtherNet/IP, or Modbus industrial protocol. Includes a PROFINET Engine to provide a hardware-assisted PROFINET interface that supports a minimum I/O cycle time of 1 msec.
  - Supports grabbing from GigE Vision-compatible cameras<sup>1</sup>.
  - PoE support for up to 15.4 W (802.3af / 802.3at Type 1, Class 3).

---

1. Note that for optimal performance in the case of a GigE Vision-compatible camera, connect the camera directly to Matrox Indio, instead of using a router or network switch in between (although supported). To acquire images from multiple cameras and want to ensure no dropped frame, you can install and use multiple Matrox Indio boards in one computer. See *Chapter 3: Using multiple Matrox Indio boards* for information.

## 68 Appendix B: Technical information

- Handles 10/100/1000 Mbits/sec connections.
- Supports jumbo frames/packets up to 9014 bytes.
- Selectable interrupt moderation rate.
- Realizable receive buffers/descriptors.
- Supports auto MDIX (signal crossover).
- 128 Mbytes of DDR3 SDRAM. Total memory bandwidth of up to 800 Mbytes/sec (400 MHz clock on an 8-bit wide DDR3 interface).
- Support for MIL license fingerprint and storage.

## Electrical specifications

### Power consumption of Matrox Indio

The following table describes the power consumption of Matrox Indio.

Power consumption of Matrox Indio	
Matrox Indio	<p>0.9 A maximum from 3.3 V rail. 1.7 A maximum from 12 V rail (when 15.4 W is drawn on PoE).</p> <p>Matrox Indio requires a 25 W capable slot if a PoE device is connected to the Gigabit Ethernet connector. The PoE +48 V is generated from the PCIe +12 V rail. Refer to PCI Express Card Electromechanical Specification Revision 3.0 for details on power supply rail requirements.</p>

### Operating voltage and current for the auxiliary signals

The following tables describe the operating voltage and current for the Matrox Indio auxiliary input and output signals.

Operating voltage and current for the auxiliary input signals	
<b>24 V input mode</b> <b>(with and without on-board pullup<sup>1</sup>)</b>	<p>Low level: 0 to 5 V. High level: 11 to 24 V (26.4 V abs. max). Maximum sinking/sourcing current of 2 mA at 24 V.</p>
<b>24 V input mode with bleeding resistor</b> <b>(as per EN 61131-2 Type-2 Digital Input)</b>	<p>Low level: 0 to 5 V. High level: 11 to 24 V (26.4 V abs. max). Sinking/sourcing current across input:</p> <ul style="list-style-type: none"> <li>• Minimum of 2 mA at 5 V (maximum low level voltage).</li> <li>• Maximum of 6.5 mA at 11 V (minimum high level voltage).</li> <li>• Maximum of 14 mA at 24 V (maximum high level voltage).</li> </ul>
<b>TTL input mode</b>	<p>Low level: 0 to 0.8 V. High level: 2.0 to 5 V. Sinking current across input:</p> <ul style="list-style-type: none"> <li>• Minimum of 50 µA at 0.8 V (maximum low level voltage).</li> <li>• Maximum of 1.1 mA at 2.0 V (minimum high level voltage).</li> <li>• Maximum of 4.5 mA at 5.0 V (maximum high level voltage).</li> </ul>

1. The on-board 2.2 KOhm pullup has a 0.5 W power rating.

Operating voltage and current for the auxiliary output signals	
<b>24 V output mode (with and without on-board pullup<sup>1</sup>)</b>	3 V maximum voltage drop across the AUX_OUT+ and AUX_OUT- pins when sinking/sourcing up to 100 mA. <sup>2 3</sup> Operating voltage: 24 V (26.4 V abs. max).
<b>TTL output mode</b>	High level: 5 V maximum, 2.4 V minimum when sourcing up to 8 mA. Low level: 0.01 V maximum.

1. The on-board 2.2 KOhm pullup has a 0.5 W power rating.
2. Note that the auto-resettable fuse protecting each signal will eventually trip if more than 100 mA of current is drawn.
3. The maximum time-to-trip of the auto-resettable fuse is 5 sec at 0.5 A when operating at 23°C.

### Timings of auxiliary input signals

The following table describes the timings for the Matrox Indio auxiliary input signals.

Timings for the auxiliary input signals	
All 24 V input modes	ON-to-OFF response time: 85 µsec. OFF-to-ON response time: 100 µsec.
TTL input mode	ON-to-OFF response time: 85 µsec. OFF-to-ON response time: 10 µsec.

### Timings of auxiliary output signals (use only as a reference)

The following table describes timings that you can use as a reference for the Matrox Indio auxiliary output signals. The ON-to-OFF and OFF-to-ON response times of the auxiliary output signals depend on the thresholds, the load, and the minimum pulse width of the connected device, and on the temperature and configuration (with or without on-board pullup). However, as a reference, you can use the following timings.

Reference for the timings of the auxiliary output signals (taken under specific test conditions)	
Timings for the auxiliary input signals	
All 24 V output modes	ON-to-OFF response time <sup>1</sup> : 140 µsec to reach 11 V <sup>2</sup> . OFF-to-ON response time <sup>1</sup> : 5 µsec to reach 5 V <sup>2</sup> .
TTL output mode	ON-to-OFF response time <sup>3</sup> : 30 µsec to reach 2 V <sup>2</sup> . OFF-to-ON response time <sup>3</sup> : 3 µsec to reach 0.8 V <sup>2</sup> .

1. This occurred under the following condition: output to 24V using a 2.2 KOhm load operating at 55°C.
2. Voltage drop across the AUX\_OUT+ and AUX\_OUT- pins.
3. This occurred at an ambient temperature of 55°C.

## Dimensions and environmental specifications

---

- Dimensions: 16.76 L x 11.12 H x 1.871 W cm (6.6" x 4.376" x 0.737") from bottom edge of goldfinger to top edge of board. These values respect the dimensions of a PCIe full-height and half-length board.
- Minimum/maximum ambient operating temperature: 0°C to 55°C (32°F to 131°F).
- Minimum/maximum storage temperature: -40°C to 85°C (-40°F to 185°F).
- Operating relative humidity: 10 to 90% relative humidity (non-condensing).
- Storage humidity: 5 to 95% relative humidity (non-condensing).
- Not designed for use at altitudes exceeding 2000 m.
- Pollution degree 2 environment.
- Designed for indoor use only.
- Designed for use in a properly ventilated computer enclosure that has its cover installed.

## **Matrox Indio connectors**

Matrox Indio has two connectors on its bracket: the auxiliary I/O connector and Gigabit Ethernet connector. In addition, Matrox Indio has a bank of input mode and output mode internal connectors.

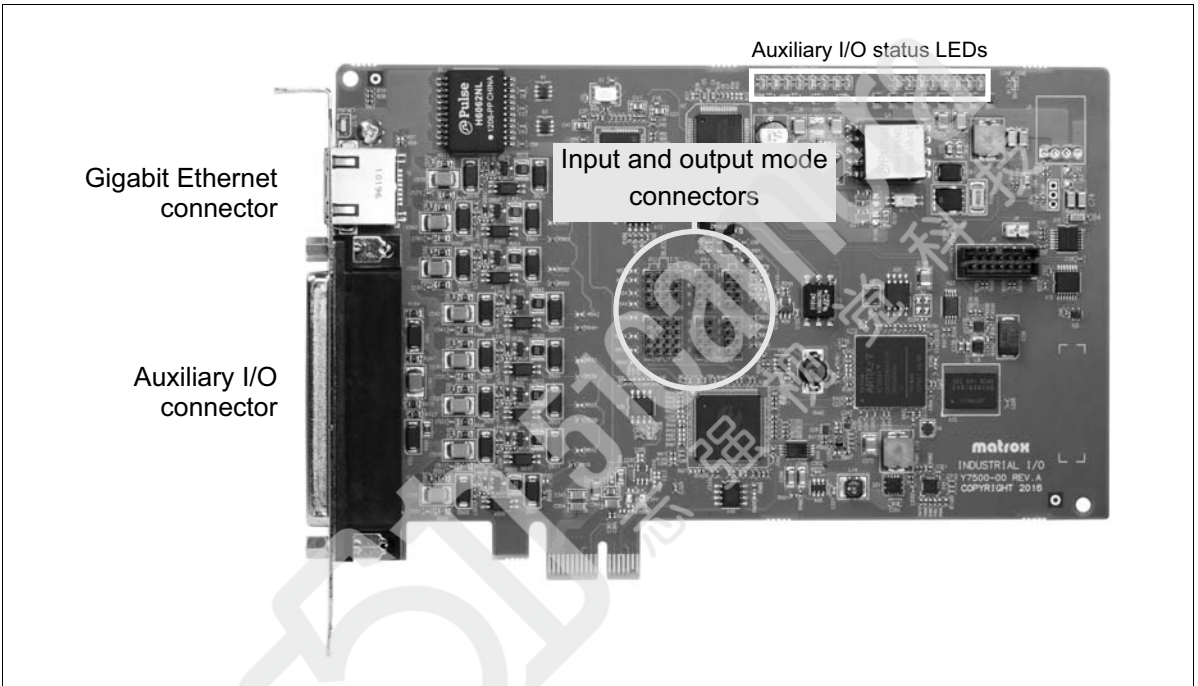



## Auxiliary I/O connector

The auxiliary I/O connector is D-subminiature 37-pin (DB-37<sup>1</sup>) female connector. The auxiliary I/O connector is used to transmit and receive the auxiliary signals. The pinout for auxiliary I/O connector is as follows.



Pin	Hardware signal name	MIL constant for auxiliary signal	Description
1-, 2+	AUX_OPTOIND_OUT0	M_AUX_IO0	Opto-isolated industrial auxiliary signal 0 (output). Supported output: user-bit 0 (M_USER_BIT0), timer output (M_TIMERn), a I/O command register bit (M_IO_COMMAND_LISTn +M_IO_COMMAND_BITn).
3-, 4+	AUX_OPTOIND_OUT1	M_AUX_IO1	Opto-isolated industrial auxiliary signal 1 (output). Supported output: user-bit 1 (M_USER_BIT1), timer output (M_TIMERn), a I/O command register bit (M_IO_COMMAND_LISTn +M_IO_COMMAND_BITn).
5-, 24+	VREF0		External voltage source used by the on-board pullup circuitry (when instantiated) of auxiliary signals 0 to 3 (output) and auxiliary signals 8 to 11 (input).
6-, 7+	AUX_OPTOIND_OUT2	M_AUX_IO2	Opto-isolated industrial auxiliary signal 2 (output). Supported output: user-bit 2 (M_USER_BIT2), timer output (M_TIMERn), a I/O command register bit (M_IO_COMMAND_LISTn +M_IO_COMMAND_BITn).
8-, 9+	AUX_OPTOIND_OUT3	M_AUX_IO3	Opto-isolated industrial auxiliary signal 3 (output). Supported output: user-bit 3 (M_USER_BIT3), timer output (M_TIMERn), a I/O command register bit (M_IO_COMMAND_LISTn +M_IO_COMMAND_BITn).
10	TTL_COM		TTL output common return path.
11-, 12+	AUX_OPTOIND_OUT4	M_AUX_IO4	Opto-isolated industrial auxiliary signal 4 (output). Supported output: user-bit 4 (M_USER_BIT4), timer output (M_TIMERn), a I/O command register bit (M_IO_COMMAND_LISTn +M_IO_COMMAND_BITn).
13-, 14+	AUX_OPTOIND_OUT5	M_AUX_IO5	Opto-isolated industrial auxiliary signal 5 (output). Supported output: user-bit 5 (M_USER_BIT5), timer output (M_TIMERn), a I/O command register bit (M_IO_COMMAND_LISTn +M_IO_COMMAND_BITn).

1. More accurately known as DC-37.

## 74 Appendix B: Technical information

Pin	Hardware signal name	MIL constant for auxiliary signal	Description
15-, 33+	VREF1		External voltage source used by the on-board pullup circuitry (when instantiated) of auxiliary signals 4 to 7 (output) and auxiliary signals 12 to 15 (input).
16-, 17+	AUX_OPTOIND_OUT6	M_AUX_IO6	Opto-isolated industrial auxiliary signal 6 (output). Supported output: user-bit 6 (M_USER_BIT6), timer output (M_TIMERn), a I/O command register bit (M_IO_COMMAND_LISTn + M_IO_COMMAND_BITn).
18-, 19+	AUX_OPTOIND_OUT7	M_AUX_IO7	Opto-isolated industrial auxiliary signal 7 (output). Supported output: user-bit 7 (M_USER_BIT7), timer output (M_TIMERn), a I/O command register bit (M_IO_COMMAND_LISTn + M_IO_COMMAND_BITn).
20-, 21+	AUX_OPTOIND_IN8	M_AUX_IO8	Opto-isolated industrial auxiliary signal 8 (input). Supported input: interrupt/poll (M_AUX_IO8), timer clock (M_TIMERn), timer arm (M_TIMER_ARM_SOURCE), I/O command list counter source, reference latch trigger (M_REFERENCE_LATCH_TRIGGER_SOURCE), quadrature input bit 0 or 1 (M_ROTARY_ENCODER_BITn_SOURCE), rotary decoder counter reset source (M_ROTARY_ENCODER_RESET_SOURCE).
22-, 23+	AUX_OPTOIND_IN9	M_AUX_IO9	Opto-isolated industrial auxiliary signal 9 (input). Supported input: interrupt/poll (M_AUX_IO9), timer clock (M_TIMERn), timer arm (M_TIMER_ARM_SOURCE), I/O command list counter source, reference latch trigger (M_REFERENCE_LATCH_TRIGGER_SOURCE), quadrature input bit 0 or 1 (M_ROTARY_ENCODER_BITn_SOURCE), rotary decoder counter reset source (M_ROTARY_ENCODER_RESET_SOURCE).
25-, 26+	AUX_OPTOIND_IN10	M_AUX_IO10	Opto-isolated industrial auxiliary signal 10 (input). Supported input: interrupt/poll (M_AUX_IO10), timer clock (M_TIMERn), timer arm (M_TIMER_ARM_SOURCE), I/O command list counter source, reference latch trigger (M_REFERENCE_LATCH_TRIGGER_SOURCE), quadrature input bit 0 or 1 (M_ROTARY_ENCODER_BITn_SOURCE), rotary decoder counter reset source (M_ROTARY_ENCODER_RESET_SOURCE).
27-, 28+	AUX_OPTOIND_IN11	M_AUX_IO11	Opto-isolated industrial auxiliary signal 11 (input). Supported input: interrupt/poll (M_AUX_IO11), timer clock (M_TIMERn), timer arm (M_TIMER_ARM_SOURCE), I/O command list counter source, reference latch trigger (M_REFERENCE_LATCH_TRIGGER_SOURCE), quadrature input bit 0 or 1 (M_ROTARY_ENCODER_BITn_SOURCE), rotary decoder counter reset source (M_ROTARY_ENCODER_RESET_SOURCE).
29-, 30+	AUX_OPTOIND_IN12	M_AUX_IO12	Opto-isolated industrial auxiliary signal 12 (input). Supported input: interrupt/poll (M_AUX_IO12), timer clock (M_TIMERn), timer arm (M_TIMER_ARM_SOURCE), I/O command list counter source, reference latch trigger (M_REFERENCE_LATCH_TRIGGER_SOURCE), quadrature input bit 0 or 1 (M_ROTARY_ENCODER_BITn_SOURCE), rotary decoder counter reset source (M_ROTARY_ENCODER_RESET_SOURCE).

Pin	Hardware signal name	MIL constant for auxiliary signal	Description
31-, 32+	AUX_OPTOIND_IN13	M_AUX_IO13	<p>Opto-isolated industrial auxiliary signal 13 (input).</p> <p>Supported input: interrupt/poll (M_AUX_IO13), timer clock (M_TIMERn), timer arm (M_TIMER_ARM_SOURCE), I/O command list counter source, reference latch trigger (M_REFERENCE_LATCH_TRIGGER_SOURCE), quadrature input bit 0 or 1 (M_ROTARY_ENCODER_BITn_SOURCE), rotary decoder counter reset source (M_ROTARY_ENCODER_RESET_SOURCE).</p>
34-, 35+	AUX_OPTOIND_IN14	M_AUX_IO14	<p>Opto-isolated industrial auxiliary signal 14 (input).</p> <p>Supported input: interrupt/poll (M_AUX_IO14), timer clock (M_TIMERn), timer arm (M_TIMER_ARM_SOURCE), I/O command list counter source, reference latch trigger (M_REFERENCE_LATCH_TRIGGER_SOURCE), quadrature input bit 0 or 1 (M_ROTARY_ENCODER_BITn_SOURCE), rotary decoder counter reset source (M_ROTARY_ENCODER_RESET_SOURCE).</p>
36-, 37+	AUX_OPTOIND_IN15	M_AUX_IO15	<p>Opto-isolated industrial auxiliary signal 15 (input).</p> <p>Supported input: interrupt/poll (M_AUX_IO15), timer clock (M_TIMERn), timer arm (M_TIMER_ARM_SOURCE), I/O command list counter source, reference latch trigger (M_REFERENCE_LATCH_TRIGGER_SOURCE), quadrature input bit 0 or 1 (M_ROTARY_ENCODER_BITn_SOURCE), rotary decoder counter reset source (M_ROTARY_ENCODER_RESET_SOURCE).</p>

To build your own cable, you can purchase the parts in the table below. These parts can be purchased from third parties such as Digi-Key Corporation ([www.digikey.com](http://www.digikey.com)).

	<b>Mating information</b>
Manufacturer:	FCI
Connector:	865637PLTXLF
Contact terminal (box of 500, AWG 24/28):	865635006
Backshell:	86303640BLF

If you do not want to make your own cable, you can purchase compatible cables from the following manufacturers:

<b>Manufacturer</b>	<b>Part number</b>	<b>Description</b>
CableWholesale	10D4-01206	DB-37 cable, male/female, length: 6 ft.
Sealevel Systems Inc.	CA112	DB-37 extension cable, male/female, length: 72".
SF Cable Inc.	SKUD720-03	DB-37 cable, male/female, length: 3 ft.
Monoprice	100514	DB-37, male/female, length: 6 ft.

The following terminal blocks can be used to connect the above-mentioned DB-37 cables to external I/O modules:

<b>Manufacturer</b>	<b>Part number</b>	<b>Description</b>
Electronics Salon	MD-D208T-1	DB-37 D-Sub DIN rail mount interface modules, male/female connectors, 37 screw terminals.
Sealevel Systems Inc.	TB02-KT	Terminal block kit with DB-37 male/female connectors and 37 screw terminals.

**Gigabit Ethernet connector**

The Gigabit Ethernet connector (10/100/1000 BaseT) is an 8-pin, RJ45 connector. The pinout of this connector follows the 1000 BaseT Gigabit Ethernet standard found in the IEEE 802.3-2002 standard. The connector also supports power-over-Ethernet (PoE).

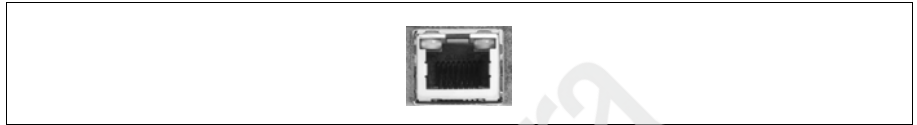

**Input and output mode connectors**

There is a bank of 8 input mode connectors and 8 output mode connectors on the Matrox Indio board.

**Input mode connectors**

The input mode connectors are standard, 2 mm spacing, 4-pin male connectors that allow you to set the input mode of an auxiliary input signal using a jumper. The description of possible jumper positions is as follows:

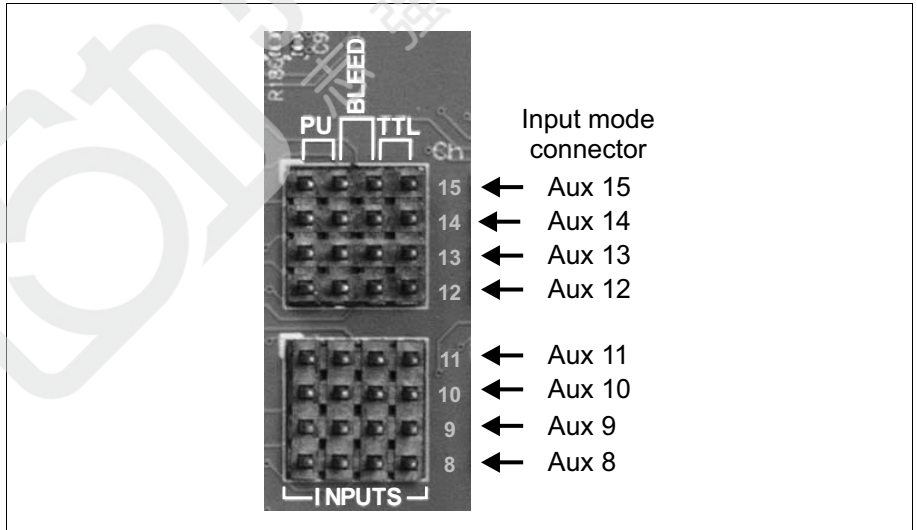

Position of jumper on an input mode connector	Description
Not installed	24 V input mode (0-5 V: logical low, 11-24 V: logical high). (default)
1-2	24 V input mode with 2.2 KOhm pullup resistor, instantiated on AUX_IN+ pin.
2-3	24 V input mode with 2.2 KOhm bleeder resistor, instantiated between AUX_IN+ pin and AUX_IN- pin. Needed to support a 2-wire proximity sensor.
3-4	TTL input mode (0-0.8 V: logical low, 2.0-5.0 V: logical high).

### Output mode connectors

The output mode connectors are standard, 2 mm spacing, 4-pin male connectors that allow you to set the output mode of an auxiliary output signal using a jumper. The description of possible jumper positions is as follows

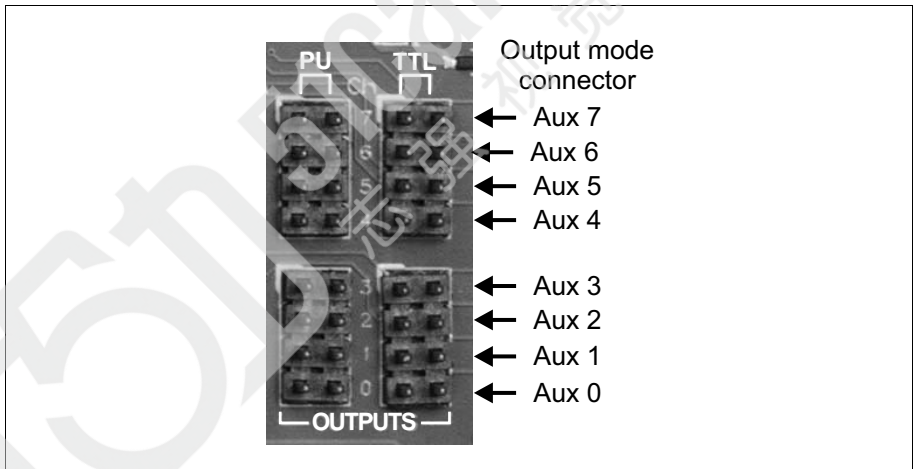

Position of jumper on an output mode connector	Description
Not installed	24 V output mode. Up to 100 mA sinking/sourcing current when output is turned on/closed. (default)
1-2	24 V output mode with 2.2 KOhm pullup resistor, instantiated on AUX_OUT+ pin.
3-4	TTL output mode. Logical high level made possible using an internally isolated 5V through a 300 Ohm pullup on AUX_OUT+ pin.

## LEDs on Matrox Indio

Matrox Indio has LEDs to display the status of the Ethernet network interface, the auxiliary I/O signals, and the status of hardware-assisted PROFINET.

### Gigabit Ethernet status LEDs

Gigabit Ethernet connector has two LEDs to communicate its status:

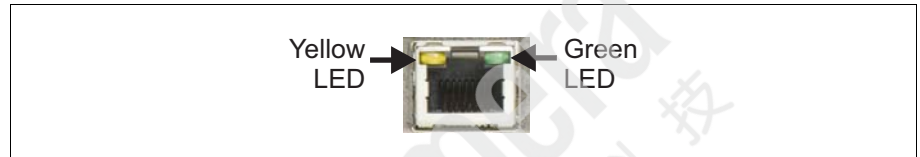

LED	LED color and state	Description
Yellow LED	solid	The interface is connected to a network at 1000 Mbits/sec.
	blinking	The interface is connected to a network at 1000 Mbits/sec and is transferring/receiving data.
	off	The interface is <b>not</b> connected to a network at 1000 Mbits/sec. If the Green LED is also off, there is no connection present.
Green LED	solid	The interface is connected to a network at 10/100 Mbits/sec.
	blinking	The interface is connected to a network at 10/100 Mbits/sec and is transferring/receiving data.
	off	The interface is <b>not</b> connected to a network at 10/100 Mbits/sec. If the Yellow LED is also off, there is no connection present.

### Auxiliary I/O status LEDs

Each of the 16 auxiliary I/O signals is associated with a status LED. Each of the auxiliary input signals is associated with an input status LED; each of the auxiliary output signals is associated with an output status LED.

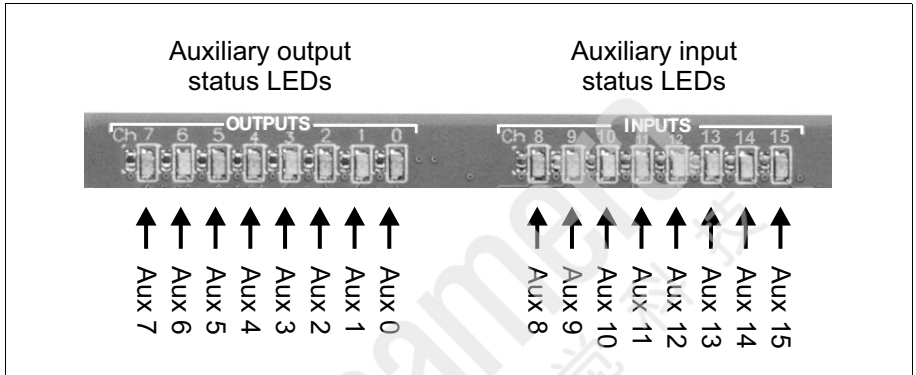

LED	LED color	Description
An auxiliary output status LED	green	The corresponding auxiliary output signal is “turned on” (connection between the AUX_OUT+ and AUX_OUT- pins is “closed” and allows current to flow).
	off	The corresponding auxiliary output signal is “turned off” (connection between the AUX_OUT+ and AUX_OUT- pins is “open” so current does not flow).
An auxiliary input status LED	green	The sensor of the corresponding auxiliary input signal is detecting a “logical high level”. The voltage threshold is met across the AUX_IN+ and AUX_IN- pins.
	off	The sensor of the corresponding auxiliary input signal is detecting a “logical low level”. The voltage threshold is not met across the AUX_IN+ and AUX_IN- pins.



### Hardware-assisted PROFINET LED

The hardware-assisted PROFINET LED communicates the status of the PROFINET engine. The LED is visible from the outside of the computer chassis through a hole in the bracket.

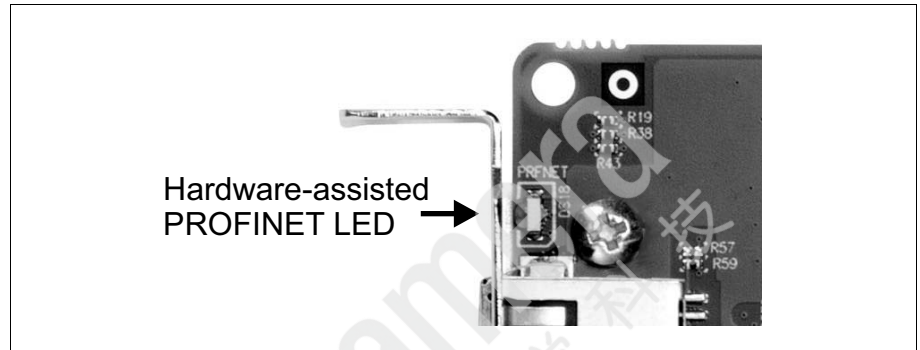

LED color	Description
off	The PROFINET engine is either: <ul style="list-style-type: none"> <li>• Disabled. Hardware-assisted PROFINET is disabled (in the MILConfig utility).</li> <li>• Enabled and a connection has been established with the PROFINET controller (for example, a PLC).</li> </ul>
red	The PROFINET engine is enabled, but a connection has not been established with the PROFINET controller
flashing green	A device Identification diagnostic is being performed and a connection has been established with the PROFINET controller. To establish which PROFINET device corresponds to a device listed in the Siemens Totally Integrated Automation (TIA) Portal application, you can enable the <b>LED flashes</b> option in the <b>Assign name</b> pane of the <b>Diagnostics</b> item of the tree structure in the application. When this option is enabled and a connection has been established with the PROFINET controller, this LED flashes green.
flashing between red and orange	A device Identification diagnostic is being performed, but a connection has not yet been established with the PROFINET controller. You perform the diagnostic as you would to make the LED flash green.



# Index

## !

100/1000 BaseT ??-76, ??-76

## A

ASPM 20  
auxiliary I/O connector 73  
auxiliary I/O interface 54  
auxiliary signals 69, 73

## B

bandwidth  
defined 62

## C

Connecting  
100/1000 BaseT ??-76, ??-76  
connectors  
auxiliary I/O connector 73  
Ethernet 77

## D

DDR3 SDRAM  
defined 62

## E

electrical specifications 69  
Ethernet 21, 77  
connectors 77

## G

global information 66

## I

installation  
hardware 18  
multiple boards 50

## L

Latency  
defined 62

## M

M\_SYSTEM\_INDIO 50  
Matrox Indio 1, 50  
MIL 11  
MIL-Lite 11, 50, 56  
multiple boards 50

## N

Network 21-22  
non-PoE 60

## P

Payload  
defined 62  
PCIe  
defined 62  
Gen 2 18  
PCIe slot 18  
PoE 60  
power 20, 60

## Q

Quadrature input  
Gray code 56

## R

RJ-45 See Ethernet  
rotary decoders 56  
Rotary encoder  
defined 63

## S

SDRAM 68  
software supported 10  
specifications  
electrical 69  
technical 66

## T

technical specifications 66

timer output  
defined 63  
TTL devices, connecting to 34



# Regulatory compliance

Note the following about the Matrox hardware products supported by this guide:

- They comply with Class B limits of FCC and CISPR11.
- They have undergone testing in a typical Host computer of the same class.
- They have undergone testing for measurement, control, and laboratory use, in an industrial environment.
- They are recommended to be used with shielded cables, although not necessary.

## FCC Compliance Statement

### **Remark for the Matrox hardware products supported by this guide**

This device has been tested and found to comply with the limits for a Class B digital device, pursuant to Part 15 of the FCC Rules. These limits are designed to provide reasonable protection against harmful interference in a residential installation. This equipment generates, uses and can radiate radio frequency energy and, if not installed and used in accordance with the instructions, may cause harmful interference to radio communications. However, there is no guarantee that interference will not occur in a particular installation. If this equipment causes harmful interference to radio or television reception, which can be determined by turning the equipment off and on, the user is encouraged to try to correct the interference by one or more of the following measures:

- Reorient or relocate the receiving antenna
- Increase the separation between the equipment and receiver
- Connect the equipment into an outlet on a circuit different from that to which the receiver is connected
- Consult the dealer or an experienced radio/TV technician for help.

The user is advised that any equipment changes or modifications not expressly approved by the party responsible for compliance would void the compliance to FCC regulations and therefore, the user's authority to operate the equipment.

# **Declaration of conformity of a Class B digital device according to the FCC rules**

## **We, the Responsible Party**

Matrox

2002 Ridge Road, Champlain, NY 12919

Telephone: (514) 822-6000 (x2026)

Attention: Matrox Conformity Group

## **Declaration**

The Matrox hardware products supported by this guide comply with Part 15 of the FCC Rules.

Operation is subject to the following two conditions: (1) this device may not cause harmful interference, and (2) this device must accept any interference received, including interference that may cause undesired operation. Any question regarding this declaration should be forwarded to the above coordinates.

# **(English) Innovation, Science and Economic Development Canada Compliance Statement**

## **Remark for the Matrox hardware products supported by this guide**

These digital devices do not exceed the Class B limits for radio noise emission from digital apparatus devices set out in the Radio Interference Regulation of Innovation, Science and Economic Development Canada.

# **(Français) Conformité avec les exigences du ministère de l'Innovation, des Sciences et Développement économique Canada**

## **Remarque sur les produits matériels Matrox couverts par ce guide**

Ces appareils numériques n'émettent aucun bruit radioélectrique dépassant les limites applicables aux appareils numériques de Classe B prescrites dans le Règlement sur le brouillage radioélectrique édicté par Innovation, Sciences et Développement économique Canada.

# **(English) Information for European users – Declaration of Conformity**

## **Remark for the Matrox hardware products supported by this guide**

These devices comply with EU Directive 2014/30/EU for a Class B digital device. They have been tested and found to comply with EN55011/CISPR11 and EN61326-1/IEC61326-1.

These products have been tested in a typical class B compliant Host computer. It is assumed that these products will also achieve compliance in any class B compliant computer.

# **(Français) Informations aux utilisateurs Européens – Déclaration de conformité**

## **Remarque sur les produits matériels Matrox couverts par ce guide**

Ces unités sont conformes à la directive communautaire 2014/30/EU pour les unités numériques de classe B. Les tests effectués ont prouvé qu'elles sont conformes aux normes EN55011/CISPR11 et EN61326-1/IEC61326-1.

Ces produits ont été testés dans un système hôte typique compatible classe B. On suppose qu'ils présenteront la même compatibilité dans tout système compatible classe B.

## **(Deutsch) Information für europäische Anwender – Konformitätserklärung**

### **Anmerkung für die Matrox Hardware-Produktunterstützung durch dieses Handbuch**

Diese Geräte entsprechen EU Direktive 2014/30/EU für ein digitales Gerät Klasse B. Sie wurden getestet und entsprechen demnach EN55011/CISPR11 und EN61326-1/IEC61326-1.

Diese Produkt wurden in einem typischen, der Klasse B entsprechenden, Host-System getestet. Es wird davon ausgegangen, daß diese Produkte auch in jedem Klasse B entsprechenden System entsprechend funktionieren.

## **(Italiano) Informazioni per gli utenti europei – Dichiarazione di conformità**

### **Nota per i prodotti hardware Matrox supportati da questa guida**

Questi dispositivi sono conformi alla direttiva UE 2014/30/EU relativamente ai dispositivi digitali di Classe B. Sono stati provati e sono risultati conformi alle norme EN55011/CISPR11 e EN61326-1/IEC61326-1.

Questi prodotti sono stati provati in un tipico sistema host che conforme alla classe B. Si dà per scontato che questi prodotti raggiungeranno conformità anche in qualsiasi sistema che conforme alla classe B.

## **(Español) Información para usuarios europeos – Declaración de conformidad**

### **Observación referente a los productos de hardware de Matrox apoyados por este manual**

Estos dispositivos cumplen con la directiva de la UE 2014/30/EU para dispositivos digitales de Clase B. Dichos dispositivos han sido sometidos a prueba y se ha comprobado que cumplen con las normas EN55011/CISPR11 y EN61326-1/IEC61326-1.

Estos productos han sido sometidos a prueba en un típico sistema anfitrión que responde a los requisitos de la clase B. Se supone que estos productos cumplirán también con las normas en cualquier sistema que responda a los requisitos de la clase B.



# Directive on Waste Electrical and Electronic Equipment (WEEE)

## Europe

### **(English) European user's information – Directive on Waste Electrical and Electronic Equipment (WEEE)**

Please refer to the Matrox Web site ([www.matrox.com/environment/weee](http://www.matrox.com/environment/weee)) for recycling information.



### **(Français) Informations aux utilisateurs Européens – Règlementation des déchets d'équipements électriques et électroniques (DEEE)**

Se référer au site Web de Matrox ([www.matrox.com/environment/weee](http://www.matrox.com/environment/weee)) pour l'information concernant le recyclage.

### **(Deutsch) Information für europäische Anwender – Europäische Regelungen zu Elektro- und Elektronikgeräten (WEEE)**

Bitte wenden Sie sich an dem Matrox-Website ([www.matrox.com/environment/weee](http://www.matrox.com/environment/weee)) für Recycling Informationen.

### **(Italiano) Informazioni per gli utenti europei – Direttiva sui rifiuti di apparecchiature elettriche ed elettroniche (RAEE)**

Si prega di riferirsi al sito Web Matrox ([www.matrox.com/environment/weee](http://www.matrox.com/environment/weee)) per le informazioni di riciclaggio.

# Limited Warranty

Refer to the warranty statement that came with your product.

