

Specifications

Product name	Compact Controller for LED Light Units (Strobe Light Type)
Model	CC-ST-1024
Direct number	2000654
Drive method	Constant-voltage system
Light control method	PWM control, lighting time control
Applicable Light Units (rating)	24 V, 10 W
PWM frequency	100 KHz
Input overcurrent protection	A fuse cuts the circuit to protect the Controller from overcurrent.
Input voltage	24 VDC ±10%
Power consumption (typ.)	11.0 W (10-W LED Light Unit at maximum light intensity)
Output voltage (rating)	24 VDC
Output current (rating)	0.42 A
Operating environment (indoors only)	Temperature: 0 to 40°C, Humidity: 20% to 85% RH (no condensation)
Storage environment	Temperature: -20 to 60°C, Humidity: 20% to 85% RH (no condensation)
Vibration resistance	Acceleration: 19.6 m/s ² , frequency: 10 to 55 Hz, cycles: 3 minutes, for 1 hour each in X, Y, and Z directions
Impact resistance	Acceleration: 49.0 m/s ² , operation time: 30 ms, number of times: 3 times each in 6 directions
Cooling method	Natural air cooling
CE marking	Conforms to EMC standard EN 61326, Class A.
Environmental regulations	RoHS compliant
Materials	ABS
Weight	80 g
Accessories	Flat-blade screwdriver

Dimensional Diagram (mm)

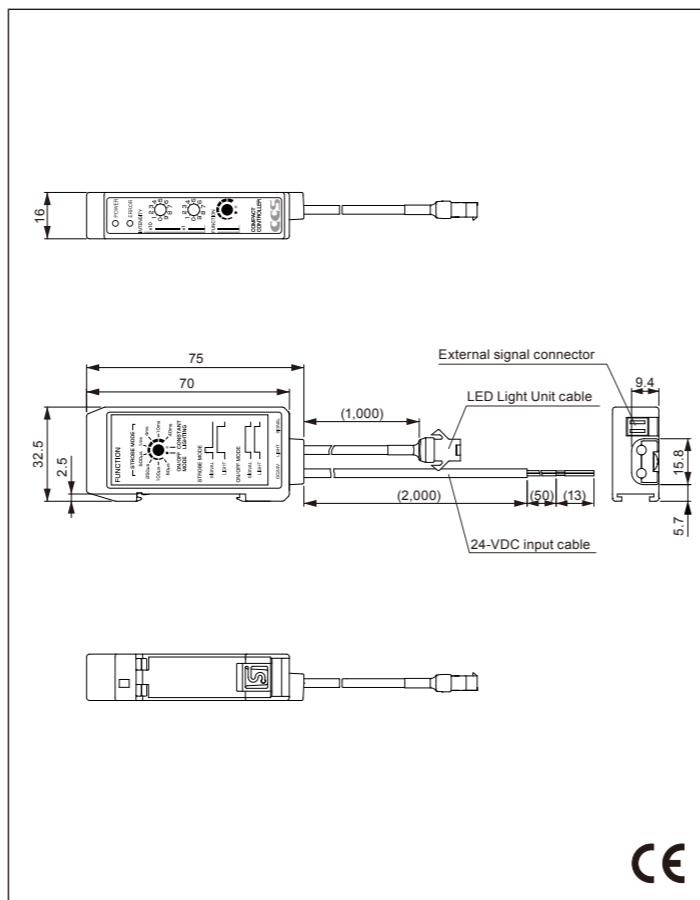

Dimensional Diagram (mm)

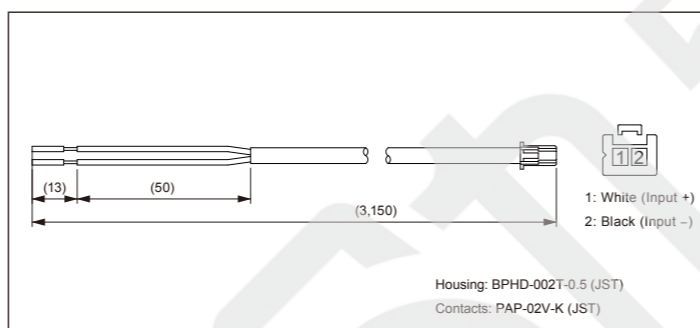

Option: NFCB2-CC-3

- External Signal Cable (3 m)



This cable is for external signals. Use it to input external signals into the Controller.

Precautions

To ensure safety, always read the Instruction Guide before attempting to use the Controller. In the interest of product improvement, specifications and designs are subject to change without notice.

CCS シーシーエス株式会社

■ 本社/テストングルーム

〒602-8011 京都市上京区烏丸通下立売上ル
TEL:075-415-8277 FAX:075-415-8278

■ 東京営業所/テストングルーム

〒141-0022 東京都品川区東五反田4-6-6 高輪台グリーンビル9F
TEL:03-5475-3681 FAX:03-5475-3682

■ 名古屋営業所/テストングルーム

〒450-0002 愛知県名古屋市中村区名駅4-6-23 第三堀内ビルディング6F
TEL:052-541-6550 FAX:052-541-6050

■ 仙台テストングルーム

〒980-0014 宮城県仙台市青葉区本町1-1-1 三井生命仙台本町ビル13F
TEL:022-224-9101 FAX:022-224-9102

URL: <http://www.ccs-inc.co.jp> E-mail: sales@ccs-inc.co.jp

Copyright © 2009 CCS Inc. All Rights Reserved.
記載内容は2009年12月現在のものです。 01002-00-0912-CC-ST

CCS
CREATIVE CUSTOMER SATISFACTION

LIGHTING SOLUTION
LIGHTING SOLUTION

Compact Controller CC-ST-1024

NEW

A Compact, Lightweight Controller for LED Light Units



(ACTUAL SIZE)

COMPACT CONTROLLER **CC-ST-1024**

NEW

シーシーエス株式会社

An LED Light Unit Controller That's the Size of a Sensor Amplifier

CC-ST-1024 Features 1 Compact Design

Smaller Than Ever Before:
An LED Light Unit Controller That's the Size of a Sensor Amplifier

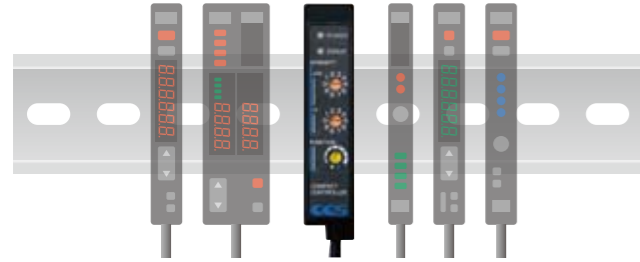

CC-ST-1024 Features 2 Ideal for Onsite Environments

With DIN rail mounting and 24-VDC input, this Controller is ideal for all types of onsite environments.

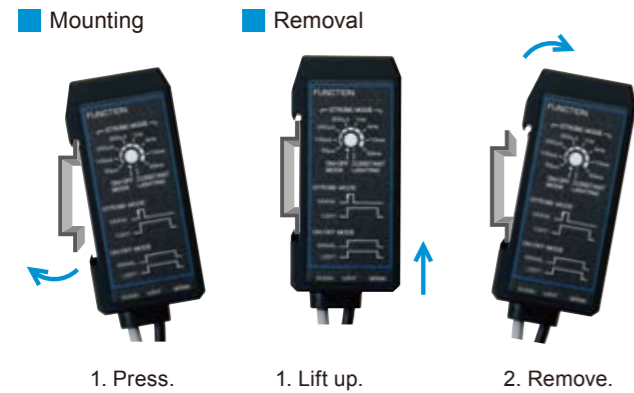

CC-ST-1024 Features 3 Easy Operation

Just set the three switches to easily control the LED Light Unit.

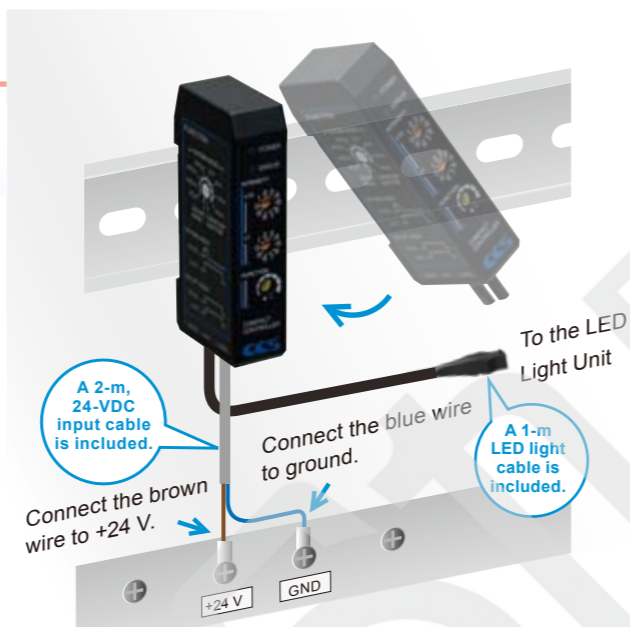
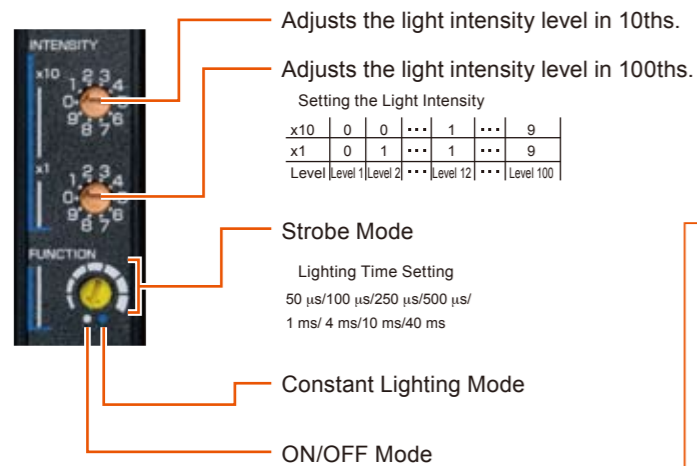

Control the LED Light Unit with Three Lighting Modes

- Strobe Mode**: In this mode, strobe lighting is synchronized with the trigger signal from the image processing device. The lighting time can be set.
- Constant Lighting Mode**: In this mode, the light is lit constantly. The intensity of the light can be set to any of 100 levels.
- ON/OFF Mode**: In this mode, lighting is synchronized with the high signal from the image processing device.

Installation Examples

Supports a Wide Range of Application Sites.

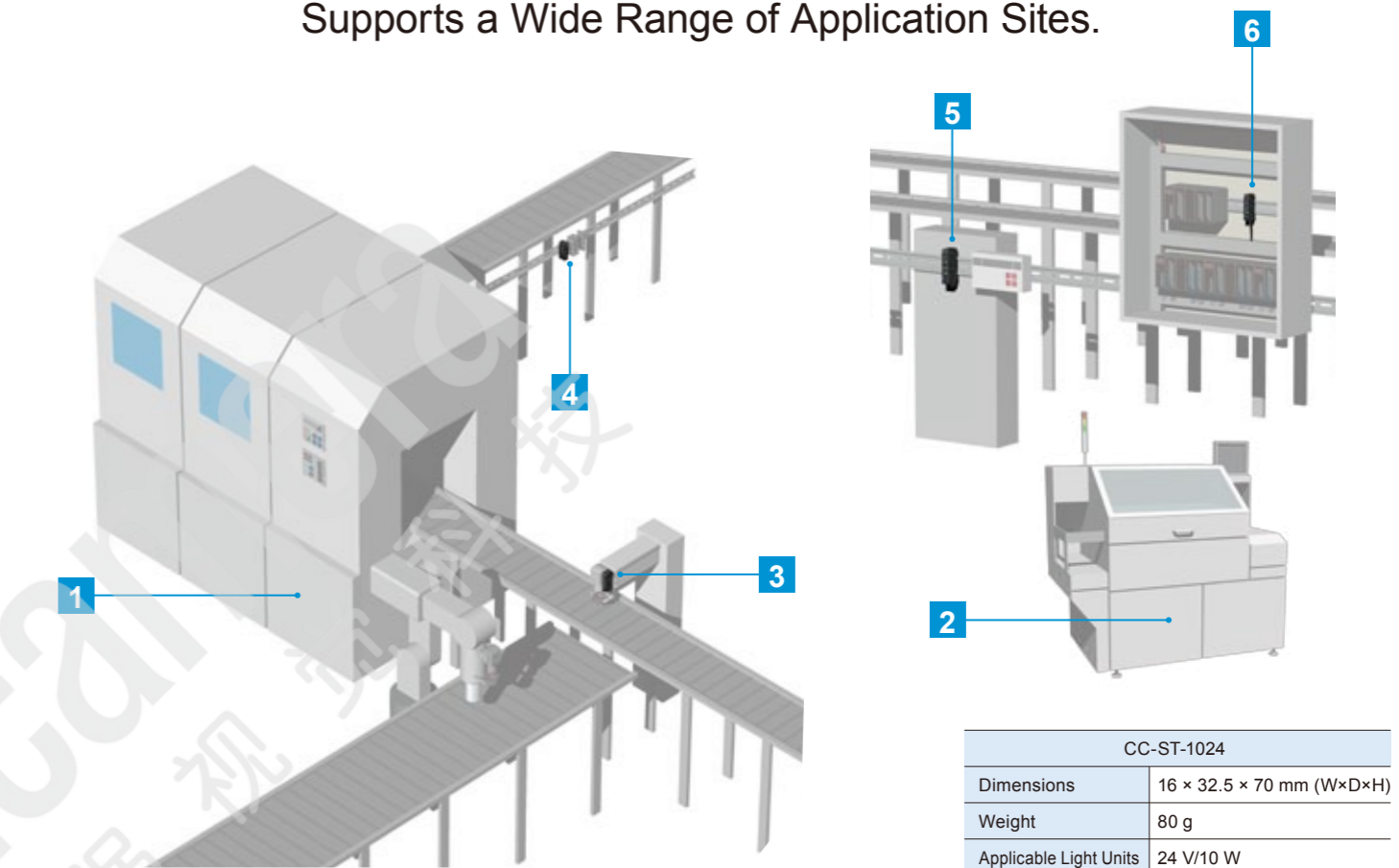

CC-ST-1024	
Dimensions	16 × 32.5 × 70 mm (W×D×H)
Weight	80 g
Applicable Light Units	24 V/10 W

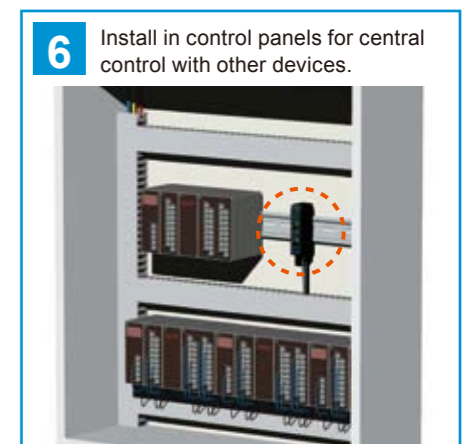
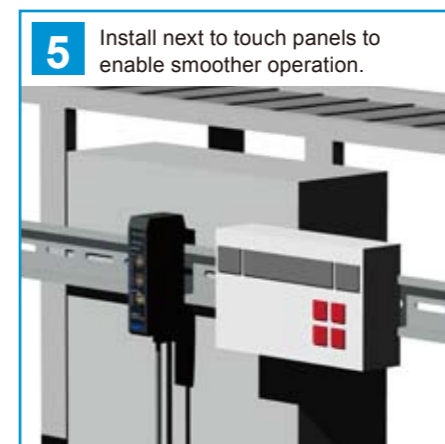
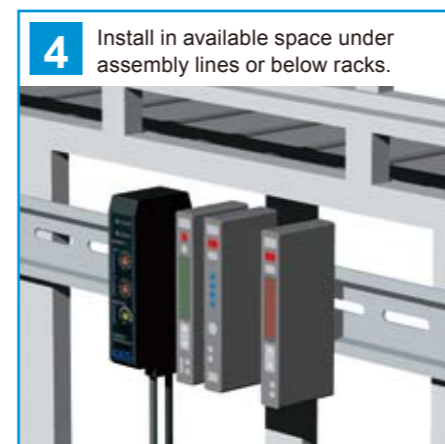
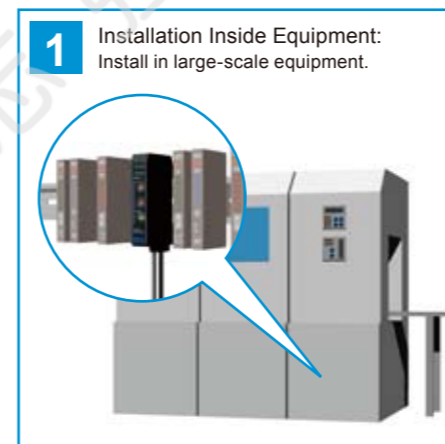

Note: These application examples are only conceptual. Actual application will depend on the installation environment.