

LNSD-200BL-HU

| | |
|-------------------|--|
| Model Name | LNSD-200BL-HU |
| LED Color | Blue |
| Input Voltage | DC24V(max.) |
| Power Consumption | 21W(max.) |
| Weight | 320g |
| Input Connector | ELP-02V x 1 (~1200mm) ELP-02V x 2 (1300mm~) |
| Polarity & Signal | 1: (+), 2: (-) |

Unit: mm

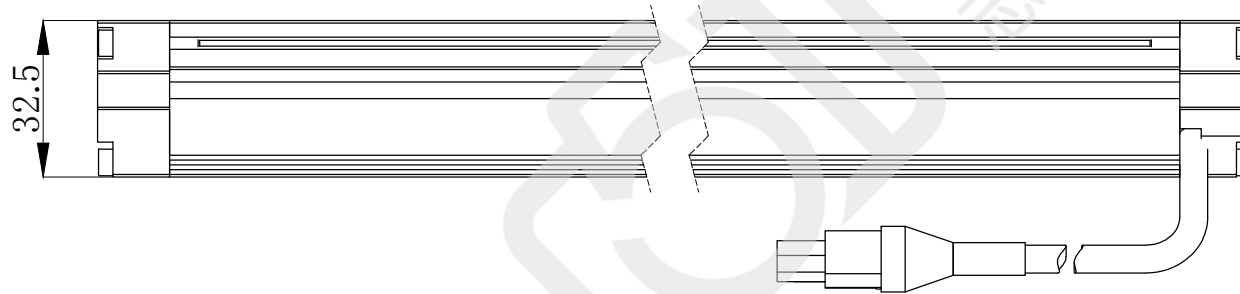
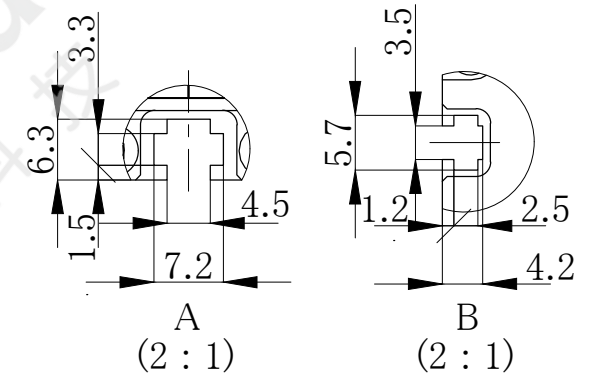
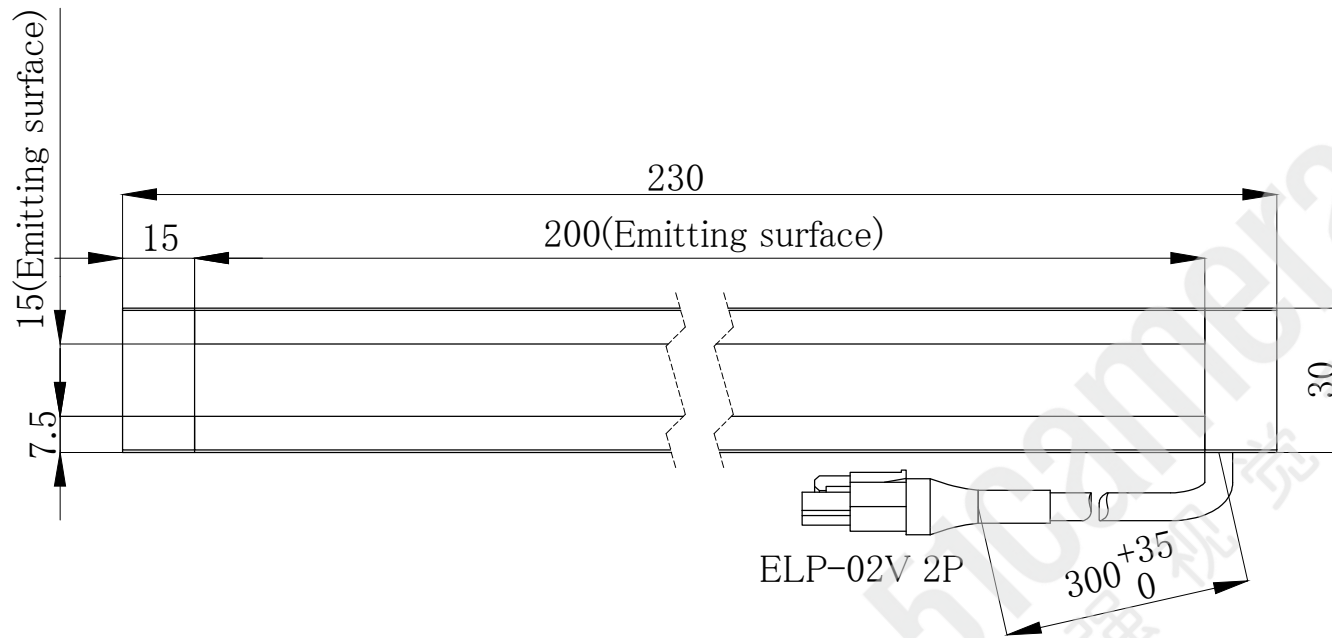

2xM3 Nut slot
(For installation)

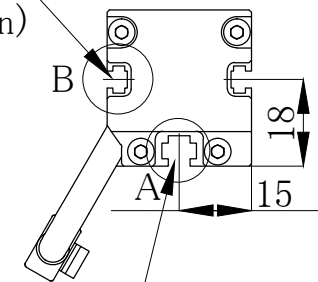

M4 Nut slot
(For installation)