

## What is Computational Imaging?

Also refer to our website.  
[www.computationalimaging.com](http://www.computationalimaging.com)

Computational Imaging (CI) refers to digital image capture and processing techniques that combine computation and optical encoding. Relying on data extracted and computed from a series of input images captured under different lighting or optical conditions, CI can improve the capability of a camera or introduce new features not previously possible. By creating an output image focused on the image properties most important to a particular machine vision task, CI offers powerful advantages over traditional one-shot imaging. Within this summary, we introduce the concept of Computational Imaging with an analogy from an every day trend in the consumer environment, and then explain how this technology is making an ever greater impact in high performance Machine Vision (MV) applications.

### Analogy with the consumer environment

Consumers want functionality such as the ability to hold up their cell phones and snap the perfect selfie with the sun setting over the beach behind them; they want to sweep them left to right in order to create panorama shots that challenge even the best of wide angle lenses!

In the case of the setting sun, the sun and sky are often thousands of times brighter than the subject of the selfie. The dynamic range of the small imagers used in cell phones is easily exceeded, yet the consumer expects to clearly see both their face and the brilliantly lit sky. To meet this expectation, many of the top cell phones now snap 2 or 3 pictures in rapid succession, each with a different exposure level. Invisible to the user, an algorithm in the background picks the most usable pixels in each image, weights them relative to each exposure level, and combines them into one single high dynamic range (HDR) image with a total dynamic range greater than possible with a single image capture.

Wide angle panorama images are created by grabbing many shots as the camera is swept left to right. An algorithm aligns each image to the last, merges the border between the two, and then repeats this for the next image in the sequence. The final wide angle panorama is a composite image created from the best pixels of all the aligned images and with a wider field-of-view (FOV) than would be possible with a single shot from a fixed imager and lens.

These techniques and many more are part of a trend to use multiple images to create a single computed output image and fit into an area called Computational Imaging. Computational imaging has slowly crept its way into the cameras on smart phones and other portable devices.

### Computational Imaging in Machine Vision

Advances in technology and the latest high speed CMOS cameras are making many computational imaging techniques viable for machine vision applications. With CI, system designers can start to think in new ways about creating solutions to difficult imaging problems. Unlike traditional image acquisition, which often requires substantial post-capture image processing and still falls short in producing the optimal image, CI — with its targeted feature extraction — directly outputs the image you need, allowing for more robust MV solutions. Better or previously impossible images for Machine Vision systems can be created at a lower cost.

By using multiple image captures and processing the computed “super image”, computational imaging directly outputs the image you need, shortening development time and allowing for more robust MV solutions.

Computational imaging is easier than ever to implement into almost any vision system. In the following pages we outline some of the typical functions that can be accomplished with applications that previously would have been difficult.

### Illumination for Computational Imaging

Computational Illumination is a necessary component of computational imaging. It refers to controlling illumination in a structured fashion, to encode the relevant information needed for digital processing. Typically, programmable lighting systems are used to create lighting sequences that vary application-specific parameters such as illumination direction or angle, wavelength, intensity, or focus.

Fundamental techniques include image-based relighting, image enhancement, image deblurring, geometry/material recovery and others. These methods are applied in numerous practical ways to enhance machine vision solutions.



## Principle of Operation

In this section we introduce the principle of Computational Imaging. The key principles of CI are:

- Computation is inherent in the image formation process
- Combines special optics and/or lighting along with image processing during image capture
- Typically involves a sequence of images with different illumination for each frame
- Covers a wide variety of techniques, all designed to output better images or images with unique characteristics
- Ends with the image acquisition process — does not involve image analysis

The illustrated example below uses Super-Resolution Color Image Capture as its theme. With this example, we can show the practical elements that comprise the steps of computational imaging. These steps can be generalized as computational illumination/optical encoding, image capture and image processing/decoding.

### Example using super-resolution color imaging

Using a monochrome camera with a CCS full-color ring light, which has 3-channel control of red, green, and blue output, the user can generate full resolution RGB color images at practical data rates. By grabbing a sequence of 3 monochrome images correlated to red, green, and blue strobes, a full color composite image at the full monochrome resolution can be created by aligning the images and using the red, green, and blue values for each pixel to create the color pixel.

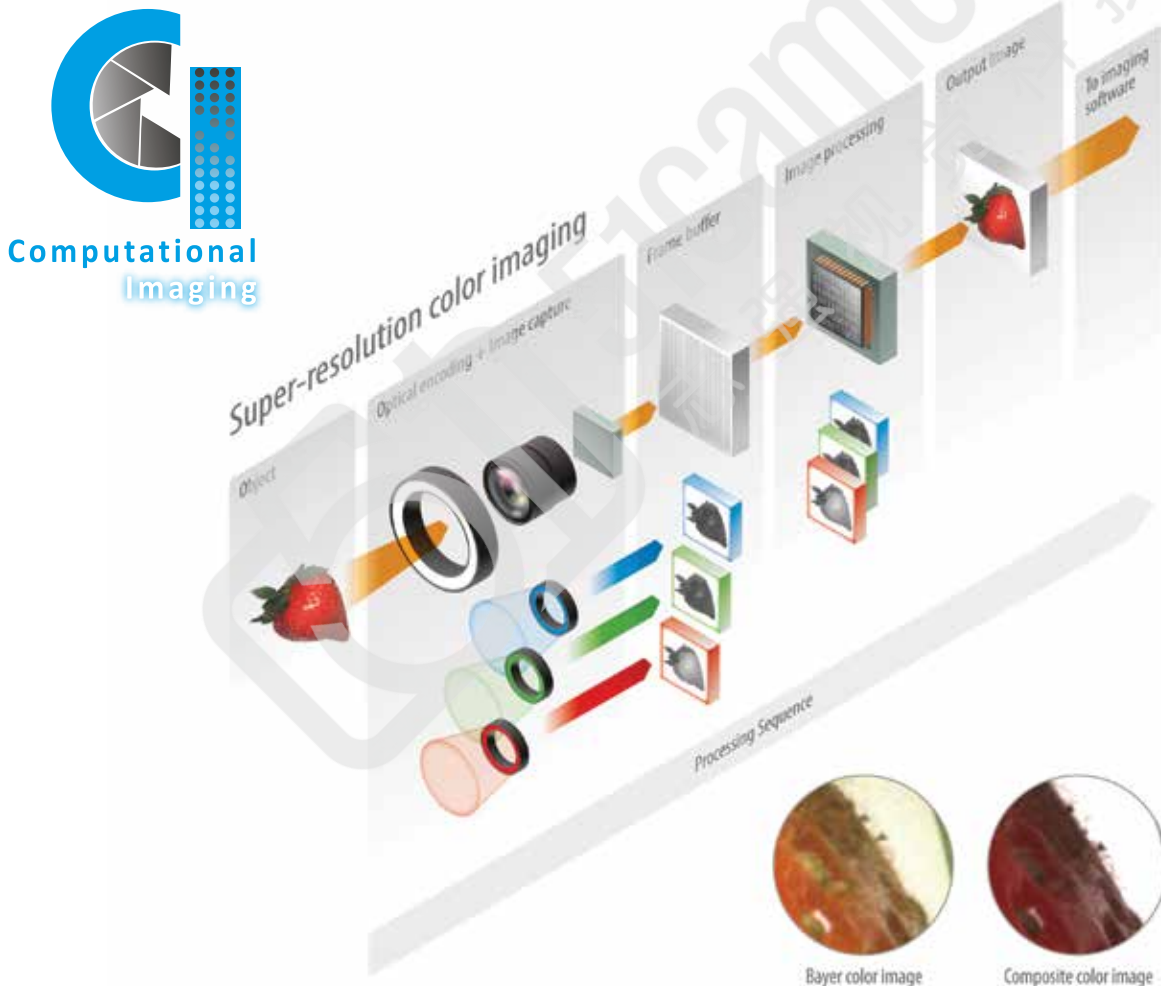

### Advantages of composite images

In this illustrated example, the resulting composite color images are much sharper than that of a single image capture with a Bayer or mosaic color camera. The images are similar to those from 3-CCD cameras without the expense, special prism or lens limitations, and at much higher resolutions than that of available 3-CCD cameras. The advantage of this method is the ability to have the best of both worlds; complete color information at the full pixel resolution of the imager. Due to the spatial effects of interpolation, Bayer color imagers capture the color information, but lose spatial resolution across several pixels.

## ▣ Practical Application Examples

### High resolution color (RGB)

Here we take a look at a practical example of the concept outlined in the previous section on the principle of Computational imaging.

Three monochrome full resolution images are captured. To get the color information, each image is strobed with a single color; Red, Green, or Blue. A color image with the full resolution of the monochrome camera can be created from the data of the 3 input images. In this example, 3 monochrome 8-bit 1600 x 1200 images are combined to make a 24-bit color 1600 x 1200 image.



### Composite color image

The advantages of this method to create composite color images becomes apparent as you zoom into feature details, as you might in a machine vision inspection.

In the zoomed image 1a, you can see the two exposed layers of the coil wire and the exit wire to the solder point. The edges are sharp and transitions are smooth with good contrast. In image 1b, the Bayer interpolation artifacts cause the wire to alias red + green along its length. Contrast to the background and between wire layers is reduced and noisy.

You can see similar effects in the 2a + 2b zoomed images. In the Bayer image 2b, the white silkscreen is almost completely Bayer noise. The red/gold/black boundaries of the test point in the lower corner become blurred and wider. In the 2a equivalent image, the silkscreen and test point are sharper, with good contrast and color.

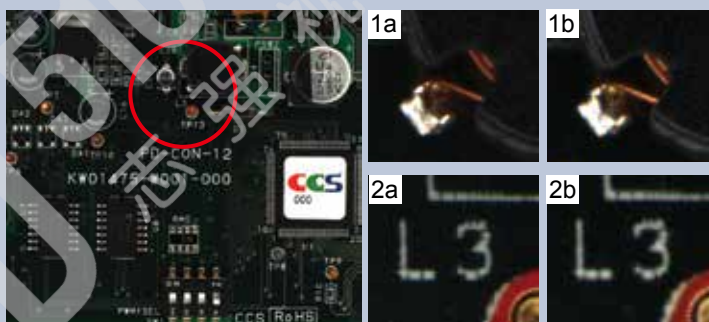

### Bright field + dark field

Bright field and dark field are two common methods of illumination for machine vision inspection. Normally, they are used independently, as most samples image best using one method or the other. But what if your sample contains some features that can only be seen with bright field, and other features that can only be seen with dark field?

Multishot imaging nicely solves this problem through the use of a combined bright field/dark field illuminator. The bright field image is combined with the dark field image to generate an output image which contains the features or defects found in both input images.

### Oil drop on scratched glass plate

The piece of glass in this example contains several types of common defects — microscopic particles, fine scratches, pits, and oil droplets on the surface.

Bright field imaging shows the droplets and larger particles, but not the fine surface details. Dark field imaging highlights all the surface details, readily showing the scratches, pits and microscopic particles. While neither bright field nor dark field lighting show everything, a CI process can produce an output image that does.

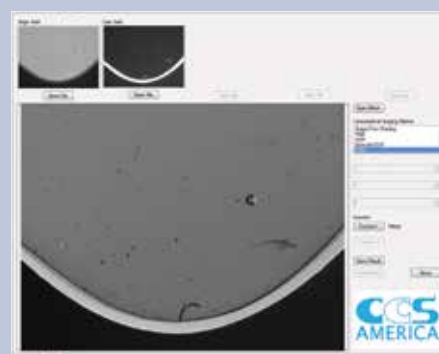

## Photometric Stereo (PMS)

Photometric stereo allows the user to separate the shape of an object from its 2D texture. It works by firing segmented light arrays from multiple angles and then processing the resulting shadows in a process called “shape from shading.” It is useful for the detection of small surface defects and 3D surface reconstruction. PMS is a height driven process which can enhance surface details like scratches, dents, pin holes, raised printing, or engraved characters. Because the final image is a computed surface based on the shading information surface coloring or features without height are removed. This can make visually noisy or highly reflective surfaces easier to inspect. This capability is rapidly becoming popular in the MV market. Numerous machine vision suppliers are offering photometric stereo tools.

A basic PMS system uses a ring light with four 90 degree quadrants to cast a directional shadow around raised features on an object. The feature map can be applied through different algorithms to show surface details that are hard to find or can't be detected in pure visual images.

### Tire inspection with PMS

The images in this example were captured with a ring light with four 90 degree quadrants. The quadrants were fired in sequence to create the West, North, South, and East images as shown on the right.

Images of the Tire Texture and Tire Shape are then created by combining these images in software as shown. The PMS routine removes the visual noise and leaves only the features of interest.



Tire - W



Tire - N

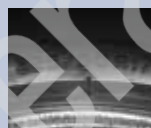

Tire - S

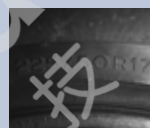

Tire - E

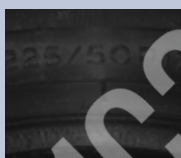

Tire Texture



Tire Shape

## CCS illumination for Computational Imaging systems

Computational Illumination from CCS provides illumination in a structured format — enabling high quality image capture in a controlled fashion. These systems are open-architecture so that they can be integrated with any GenICam cameras and many Smart cameras.

CCS provide Computational Illumination components and kits to allow for easy implementation. Please contact your CCS sales representative if you require any assistance in selecting relevant cameras and imaging software.



## LSS-2404 and segmented HPR2 Ring Light

The LSS-2404 Light Sequencing Switch is a special-purpose programmable LED Lighting controller designed to switch external +24 VDC power for up to 4 channels of lights. Upon receiving an external system trigger, the LSS-2404 executes a pre-programmed sequence of lighting on the 4 channels and outputs a set of correlated camera triggers, automatically synchronizing a series of external camera exposures to the programmed lighting sequence. Arbitrarily complex lighting sequences are possible to support any combination of Computational Imaging (multi-shot) and conventional (single-shot) image capture. Bundled software allows the user to configure the controller and update the firmware.

CCS also offers a range of segmented ring lights. The special version of HPR2 series is available in 4 segments, which is ideal in combination with the LSS-2404 for Photometric Stereo applications. All standard sizes are available in segmented form.

For more information, please visit [www.computationalimaging.com](http://www.computationalimaging.com) or contact your local CCS representative.



## Extended Depth of Field (EDOF)

All images have a depth of field (DOF), a distance over which objects appear in sharp focus. In any single image, DOF is limited by the magnification and aperture size used. In some machine vision applications, the DOF may not be great enough to focus sharply on all the objects in a scene. Conventional solutions for increasing DOF such as closing the aperture (higher  $f/\#$ ) come with substantial tradeoffs such as decreased light and less resolution.

The EDOF technique allows an image to be created with a DOF greater than any of the single images. Using EDOF image processing software and the CCS computational illumination kit, multiple images with various depths of field can be merged to return a clear, sharp result - without loss of light or resolution.

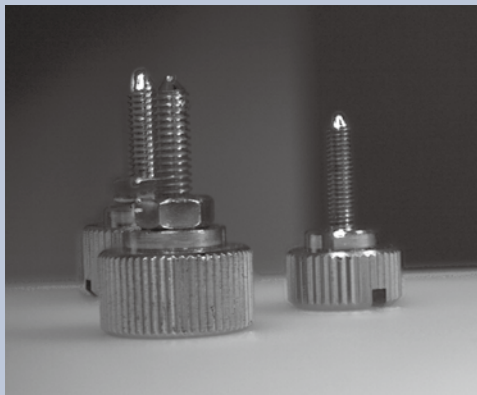

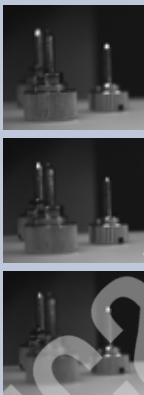

### How to get a lot more Depth of Field

To extend DOF, several input images captured at different focal planes are necessary. While there are a number of methods for EDOF imaging, two common ones are:

- Using motorized or liquid lenses to vary the focal point
- Using a chromatically uncorrected lens along with multiple wavelengths of light to induce focal plane shifts

The example to the left merged three separately focused images to produce an EDOF image with all three fasteners in sharp focus.

## High Dynamic Range (HDR)

All imagers have a limit to the ratio of the brightest object to the darkest object that can be distinguished in a single image. This is called the dynamic range. Many machine vision applications involve bright, shiny, or dark objects that challenge the dynamic range of the camera. To solve these cases, a series of images with different exposure levels can be captured to create a single HDR image with all the detail that needs to be included for the inspection.



### HDR imaging

This HDR image is created from 3 images with different exposures. Image 1 lets you see the LED die and surrounding package, but no other details are visible. Image 2 exposure allows the silkscreen and brightest parts of the components to be seen, but the LED is oversaturated.

Image 3 allows the barrel connector and other dark components to be seen, but the text and component leads are oversaturated; the LEDs are completely washed out. The HDR image allows correct exposure of the bright LEDs, proper saturation of the silkscreen and component leads, yet the dark components can still be seen.

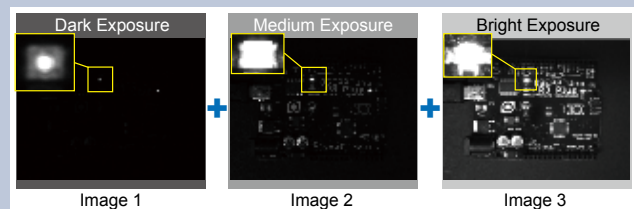

## Relevant Products

### LSS-2404 Specifications

<b>Description</b>	The LSS-2404 Light Sequencing Switch is designed to be the heart of any CI system and can switch external +24 VDC power for up to 4-channels of lights. Upon receiving an external system trigger, the LSS-2404 executes a pre-programmed sequence of lighting on the 4-channels and outputs a correlated camera trigger, automatically timing an external camera exposure to the programmed lighting sequence. May be set-up as master or slave in a system.
<b>Number of lighting channels</b>	4
<b>Input voltage</b>	10.8 – 28.8 VDC (absolute range); suitable for either 12 V or 24 V DC lighting.
<b>Power consumption</b>	5W maximum internal dissipation; excluding attached lighting and dependent on configuration.
<b>Trigger Out (to camera)</b>	Selectable to 5 V, 12 V, or 24 V via software. Voltage level tolerance +/- 15%. Maximum limited to ~93% Vin
<b>Trigger Input</b>	Voltage mode: Accepts 3.3 – 24 VDC logic level voltage with adjustable trigger level Switched Ground Mode: Use opto-isolators or closed contacts via direct connection without external components.
<b>Trigger Threshold</b>	Software programmable 1 - 24 VDC trigger level in 100 mV increments Default = 9.6 V threshold to work with 12 V or 24 V trigger logic
<b>Maximum Current Rating</b>	1 A/ch x 4-channels; 4 A maximum all channels.
<b>Communication Port</b>	RJ45 connector. 100BaseT Ethernet. TCP/IP protocol. Control via web-based GUI or TCP/IP command set.
<b>Firmware</b>	User upgradeable via GUI (included).
<b>Sequence Timing</b>	User programmable via GUI (included).
<b>Timing Resolution</b>	Maximum Trigger rate: 10,000 fps (100 $\mu$ S) Minimum output signal width: 100 $\mu$ S Timing resolution: 1 $\mu$ S Channel skew + jitter: $\leq$ 10 $\mu$ S
<b>Operating Temperature Range</b>	Range 0 to 40 $^{\circ}$ C
<b>Storage Temperature Range</b>	Range -10 to 50 $^{\circ}$ C
<b>Cooling</b>	Free air cooling (standard model)
<b>Dimensions</b>	4.13 x 6.15 x 1.57 inches L x W
<b>Weight</b>	442g

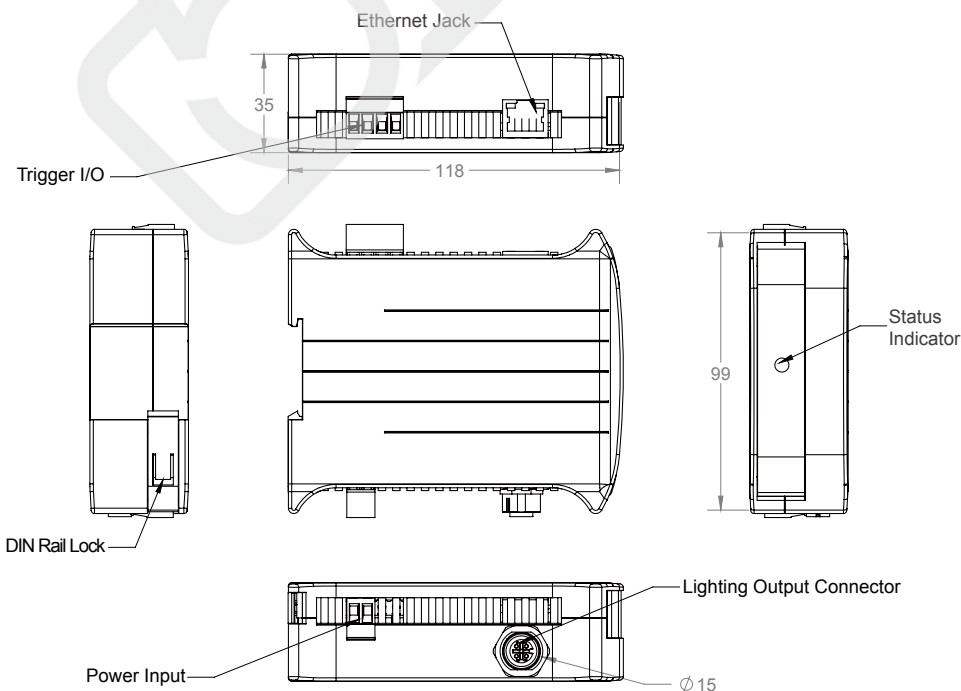

## Dimensions Segmented Ring Lights

HPR2-50SW-DV04M12-5

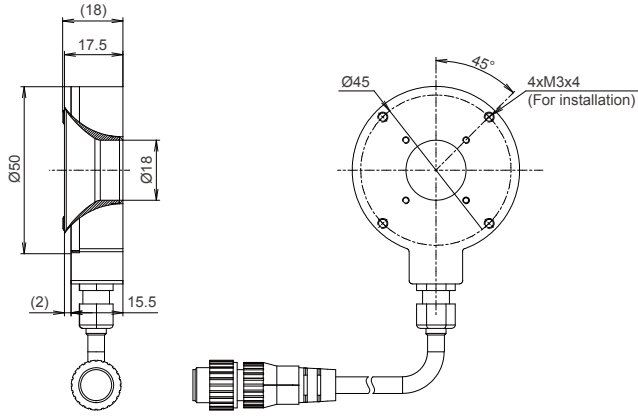

HPR2-75SW-DV04M12-5

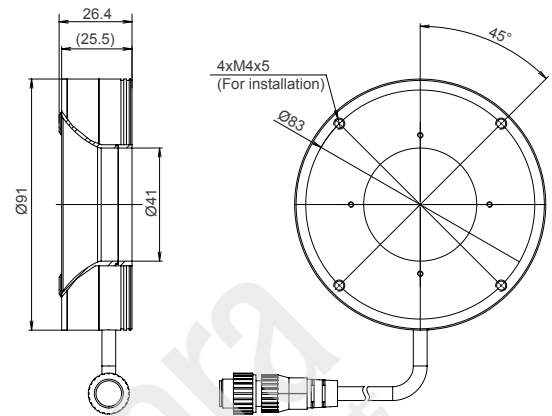

HPR2-100SW-DV04M12-5

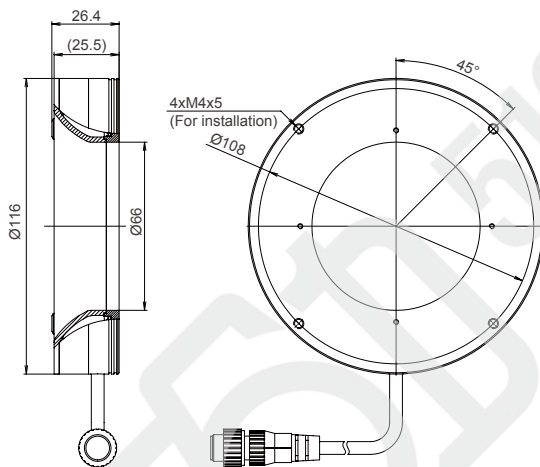

HPR2-150SW-DV04M12-5

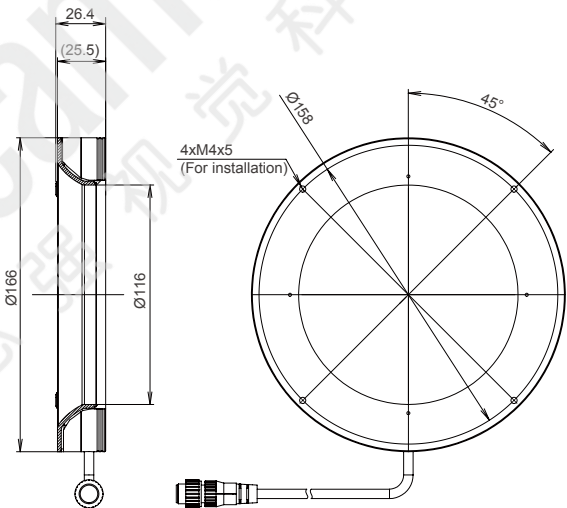

HPR2-200SW-DV04M12-5

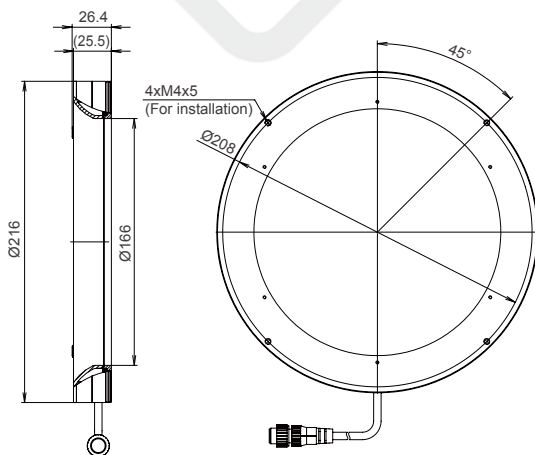

HPR2-250SW-DV04M12-5

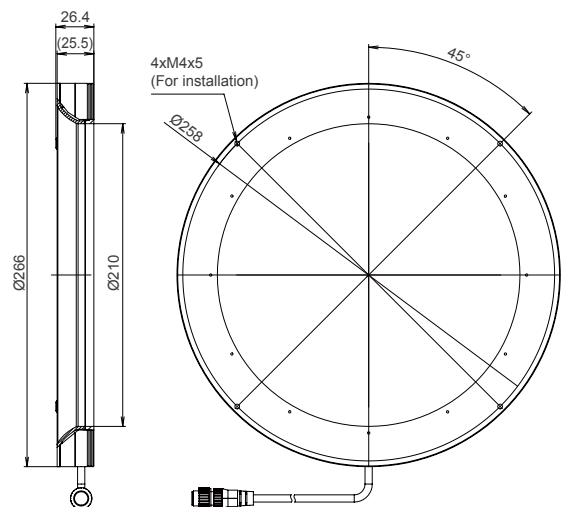

## CCS Illumination for Computational Imaging Systems

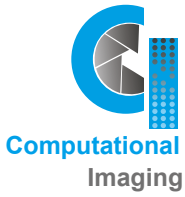

Computational Illumination from CCS provides illumination in a structured format – enabling high quality multi-shot image capture in a controlled fashion. These components are open-architecture so that they can be integrated with any machine vision camera and many smart cameras.

CCS provides a number of Computational Illumination products to allow for easy implementation. Please contact your local CCS Sales office, or CCS Partners, if you require any assistance in selecting compatible components, such as cameras, lenses and imaging software.

### CCS Computational Illumination Kit components

Item	Size	Part Number	Key specifications	Photo
Light Sequencing Switch	1.5x DIN Module	LSS-2404	The LSS-2404 Light Sequencing Switch is a programmable LED lighting controller designed to manage multi-shot image capture sequences for Computational Imaging.	
Ring Light (4 Quadrant)	50 mm 75 mm 100 mm 150 mm 200 mm 250 mm	HPR2-YYYxx-DV04M12-5  YYY=size: 50,75,100,150,200,250 mm xx=color: BL, RD, SW, IR	PMS - Photometric Stereo HDR - High Dynamic Range	
Bar Lights (4 Quadrant)	33-509 mm 300 mm 150-1500 mm  Universal	LDL2 Series LDLB Series HLDL2 Series  BK-QUADBAR-4C	PMS - Photometric Stereo HDR - High Dynamic Range  Corner Bracket Assembly w/mounting - Fits all sizes	
Full Color	33-509 mm 50-400 mm 27-500 mm 50-400 mm 13-200 mm	LDL2 Bar Lights HPR2 Ring Lights TH2 Panel Lights HPD2 Dome Lights LFV3(A) Coaxial Lights	URC - Ultra-Resolution Color CHDR - Color HDR EDOF - Extended DOF (chromatic dispersion)	
Multi-spectral	Wide Range	UV Series NIR Series Full Color Series	Wide range of form factors and sizes in UV, NIR, visible, and Full Color (RGB) lights available for any multi-spectral application.	
Segmented Full Color Light	50 mm 75 mm 100 mm 150 mm 200 mm 250 mm	HPR2 Series	Combo 4-segment + Full Color RGB 12-channel input for ultimate flexibility	
Breakout Cable	300 mm 900 mm	FCB-F-0.3-XS2-zzz FCB-F-0.9-XS2-zzz  zzz=Light Connector type: Blank=M12 (default) or SM3	4-way branch, 0.3 meters total length 4-way branch, 0.9 meters total length  Allows any four CCS lights to connect to the LSS-2404 controller.	
Extension Cables M12	1,3,5, or 9 meters	FCB-X-0.5SQM12-5M5F X=length of 1,3, 5, or 9 m	Straight extension cables for use between the LSS-2404 controller and breakout cables or lights with M12 connector.	
Extension Cables SM3	1,2,3,5, or 10 meters	FCB-XX XX=Length: 1,2,3,5, or 10 m	Straight extension cables for use between FCB-F-X-XS2 branches and CCS lights with SM3 connectors only.	
Adjustable Bracket	150 mm  Other sizes available	BK-HPR2-150-IS	Mounting bracket for camera and segmented or standard HPR2 ring light. The bracket has a slider mechanism, allowing for the camera working distance to be adjusted. Bracket mountable at either camera or light position.	
Software			Software support for Computational Imaging available through leading machine vision suppliers. Visit <a href="http://www.computationalimaging.com">www.computationalimaging.com</a> for details.	

Depending on the particular CI process, any standard light may be incorporated. CCS can create custom products such as integrated multi-spectral lights in one unit. Contact CCS for additional details.