

Lu171

1.3 Megapixel USB 2.0

Single-Board OEM Camera Module

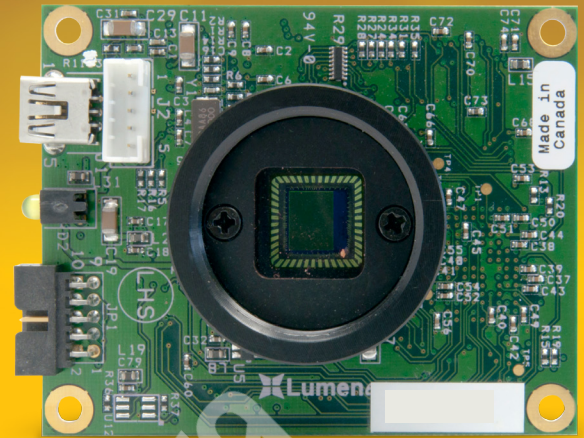

High Resolution for a Compact Size

Lumenera's Lu171 series of megapixel cameras are designed to be used in a wide variety of applications where high resolution is required. This single board camera with minimal depth will satisfy the smallest of space requirements. With 1280 x 1024 resolution and on-board processing these cameras deliver outstanding image quality and value for industrial and scientific imaging applications.

No Framegrabber Required

Uncompressed images in live streaming video and still image capture are provided across a USB 2.0 digital interface. No framegrabber is required. Advanced camera control is available through a complete Software Developer's Kit (SDK), with sample code available to quickly integrate camera functions into OEM applications.

Custom Form Factors

Hardware and software based synchronization trigger is provided standard. Lu171 model cameras are offered in board-level form although enclosure options can be made available. Custom form factor (sizes) can be provided.

Application

The Lumenera Camera SDK provides a full suite of features and functions that allow you to maximize the performance of your camera within your application. The SDK is compatible with all USB and GigE based cameras. Microsoft DirectX/DirectShow, Windows API and .NET API interfaces are provided allowing you the choice of application development environments from C/C++ to VB.NET or C#.NET. Full inline IntelliSense autocompletion and documentation is provided with the .NET API interface and is accompanied by a full API manual describing all the camera functions and properties.

Features

- Lower fixed pattern noise
- Stable, reliable camera drivers for running multiple cameras on a PC or other USB devices
- Monochrome, progressive scan, 1.3 megapixel image sensor
- 30 fps at full 1280x1024 resolution
100 fps at 640x480
- Auto white balance, auto exposure
- Snapshot mode for use with strobe
- GPI/Os for control of peripherals and synchronization of lighting (4in/4out)
- FCC Class B, CE Ready
- RGB Bayer video output
- Select 8 or 10-bit pixel data
- Simplified cabling - video, power and full camera control over a single USB cable
- CS-Mount provided
- DirectShow compatible
- Software compatible with Windows 10, Windows 8.1, Windows 7, Linux, 32 and 64-bit operating systems
- Complete SDK available
- Three (3) year warranty



Mechanical Drawings

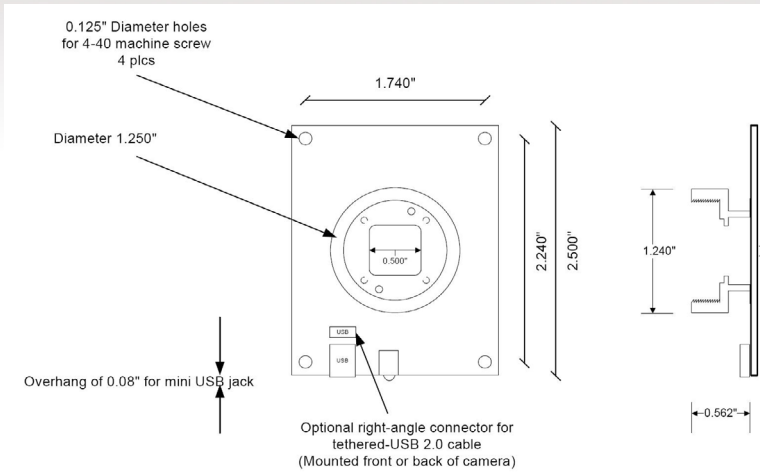

Monochrome Quantum Efficiency Curve

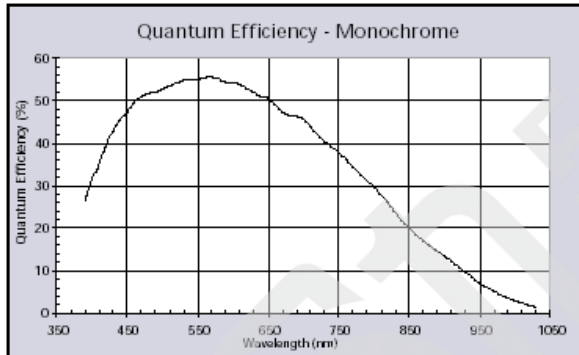

Sensor Specifications	
Image Sensor	Micron, MT9 M001, CMOS, mono progressive scan
Optical Format	1/2
Active Area	6.6 x 5.3 mm
Pixel Size	5.2 x 5.2 um
Resolution	1280 x 1024 pixels
Region of Interest Control	User selectable
Camera Specifications	
Frame Rate	30 fps @1280x1024
Bit Depth	8 or 10 bits
Binning Modes	2x2 and 4x4
Exposure Control	Manual and automatic control
Exposure Range	64us to 831ms (video), 0 to 4.16s (snapshot)
Gain Control	Manual
Gain Range	1 to 15.0 x
White Balance	Manual and automatic control
Camera Characteristics	
Sensitivity	1.3V/Lux sec
Dynamic Range	60 dB
Full Well Capacity	40,000 e-
Quantum Efficiency	55%
Read Noise	10 e-
Dark Current Noise	20 e-/s @ 25 °C
Mechanical Specifications	
Data Interface	Mini USB (or optional tethered USB cable with lock)
Lens Mount	CS-Mount (C-Mount and microlens option)
Dimensions (HxWxD)	21.59 x 50.8 x 63.5 mm (enclosed) 0.85 x 2.00 x 2.50 inch (enclosed)
Mass	~150 g (enclosed)
Operating Temperature	0 to 50 °C
Storage Temperature	-30 °C to 70 °C
Operating Humidity	0 to 95 %, non condensing
Shock / Vibration	50 g shock, 5 g (2 to 200 Hz) vibration
Onboard Memory	Camera has onboard non-volatile memory storage
Camera Software	
Operating Systems	Windows 10, Windows 8.1, Windows 7, Linux, 32 and 64-bit operating systems
Software Interfaces	Windows API, .NET, DirectX
Power and Emissions	
Power Consumption	~2.5 W
Power Requirement	USB bus power, or external 6 V DC, 500 mA
Emissions Compliances	FCC Class BE, CE Certified
Hazardous Materials	RoHS, WEEE Compliant
Warranty	Three (3) year
System Requirements	
Recommended PC Specs	<ul style="list-style-type: none"> • Pentium 4, 2.8 GHz or higher • 512 MB RAM • 60 MB hard drive free space or more • USB 2.0 Port • Windows 10, 8.1, 7; Linux
Ordering Options	
Lu171M	Mono Camera Module
LuSDK	Software Developer's Kit (Web download)
Camera Includes	
Lu802	2M USB 2.0 A to B cable
La20606	6 V DC power supply

