

Interfaces and Connectors

Data and Power Interface	10 Gigabit Ethernet	Transfer Rate	10.000 Mbits/sec
	5 Gigabit Ethernet	Transfer Rate	5.000 Mbits/sec
	2.5 Gigabit Ethernet	Transfer Rate	2.500 Mbits/sec
	Gigabit Ethernet	Transfer Rate	1.000 Mbits/sec
	Fast Ethernet	Transfer Rate	100 Mbits/sec
Connector:	M12 / 8-pol x-coded (SACC-CI-M12FS-8CON-L180-10G)		
Assignment:	1 - MX1+	2 - MX1-	
	3 - MX2+	4 - MX2-	
	5 - MX4+	6 - MX4-	
	7 - MX3-	8 - MX3+	

Process Interface	Connector:	M12/12-pin a-coded (SACC-CI-M12MS-12CON-L180)
Assignment:	1 - Power Vcc	2 - GND (Power)
	3 - IN1 (Line0)	4 - OUT1 (Line4)
	5 - IN2 (Line1)	6 - OUT2 (Line5)
	7 - OUT3 (Line6)	8 - RS232 TxD (Line2)
	9 - OUT4 (Line7)	10 - RS232 RxD (Line3)
	11 - GND (IO)	12 - Power (IO)

Lens Control Interface (located within support, reserved for future use)	Connector:	6 pin (JST BM06B-SRSS-TB)
Assignment:	1 - Power (lens)	2 - GND (lens)
	2 - UART RxD	4 - UART TxD
	5 - NC	6 - NC

Optical Data

Lens Mount	C-Mount
Optical Filter	IR cut filter

Mechanical Data

Housing	aluminum, hard anodized, IP40 (with mounted lens and 10 GigE cable) IP65/67 (with mounted tube and cable)
---------	---

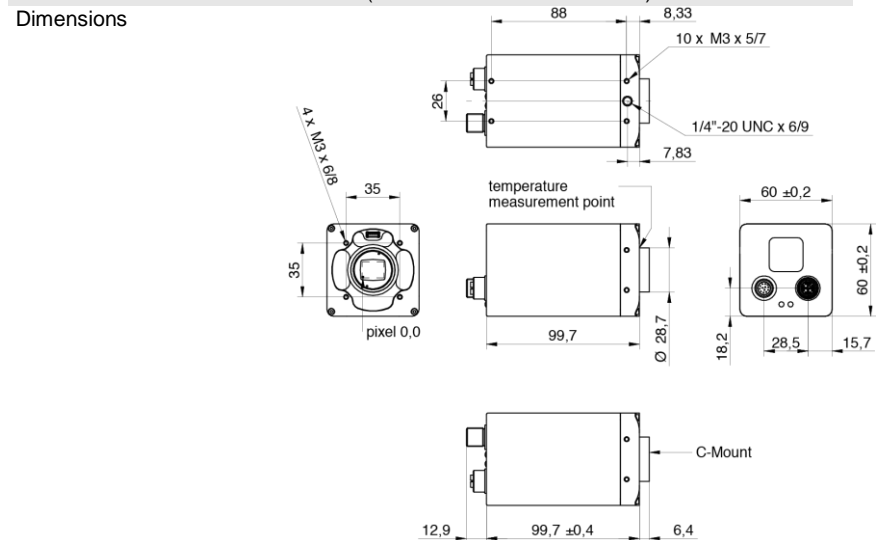

Weight	485 g
--------	-------