

C-Mount

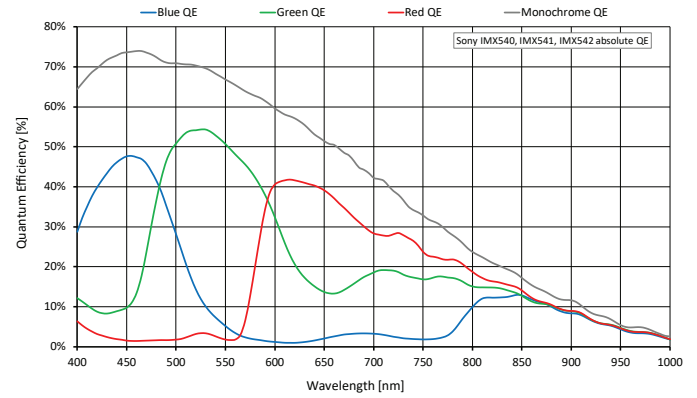
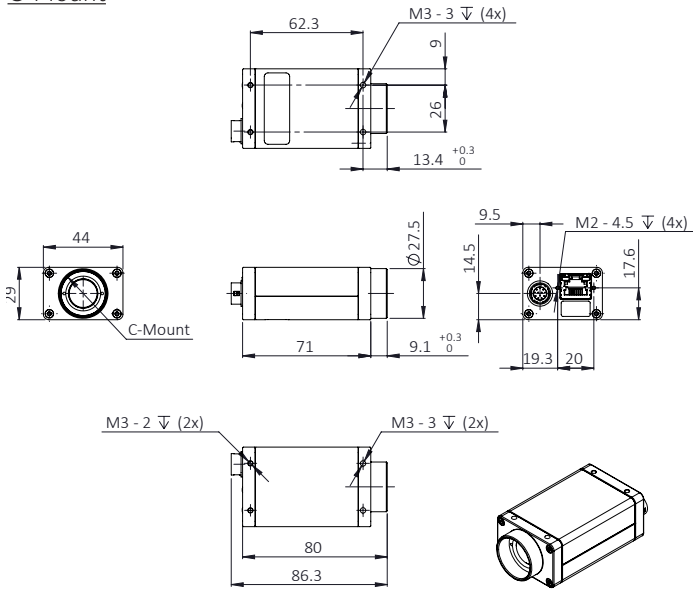

Applications

- // Industrial inspection including mobile display inspection, AR/VR display measurement, surface inspection, semiconductor packaging inspection, print inspection, 2D/3D metrology, laser beam profiling, and automated optical inspection (AOI)
- // Digital archiving of documents and films
- // Medical and life sciences applications including lab and biomedical imaging, pharma and cosmetic inspection, track and trace applications
- // Security and surveillance, aerial imaging, and remote sensing

Our All-around Offering

At Allied Vision, you get more than just a great camera. We help you find the best imaging solution for your application. Our selected accessories, such as optics and cables, ensure optimal performance. Our powerful Vimba Software Development Kit (SDK) makes the camera integration easy whatever platform you use. And our technical support experts are at your side during system integration and for the whole lifetime of your cameras.

Contact us! We will be pleased to advise you.

- // Save time and costs through easy integration into various machine vision applications
- // Benefit from the latest state-of-the-art sensor technologies
- // Rely on high-performance and stability
- // Enjoy the benefits of our platform-independent Vimba SDK for full compatibility with all popular image processing libraries