

外形尺寸

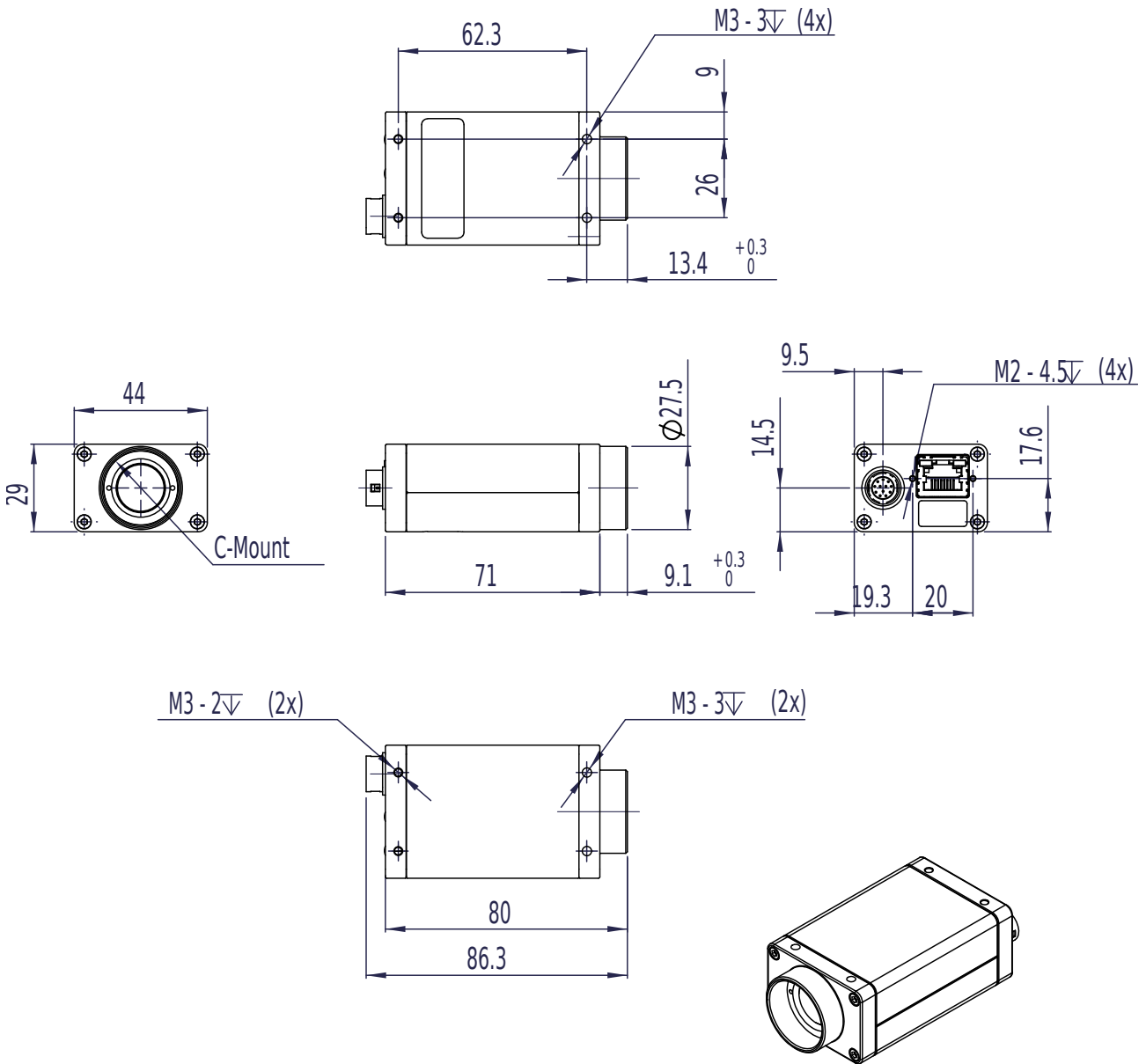

应用场景

The Manta G-040 is the perfect model for industrial applications that require accurate imaging of fast-moving subjects. Equipped with a Pregius global shutter function, the camera provides high-quality image capture that is not affected by focal plane distortion or flash bands. The Sony IMX287's 6.9 μm x 6.9 μm pixel size achieves sensitivity four times that of the IMX273. This means that the same