

VCXG-51M.I.XT

Gigabit Ethernet, 5,0 Megapixel, Monochrome

Article number: 11188955

Overview

- 2448 x 2048 px
- Sony IMX264
- 2/3" CMOS
- 24 fps
- Gigabit Ethernet
- available on request



GEN<i>i>CAM



Technical data

Sensor information

Sensor	Sony IMX264 Gen2
Mono/Color	Mono
Sensor type	2/3" CMOS
Shutter type	Global shutter
Resolution	2448 × 2048 px
Pixel size	3.45 × 3.45 μm
Exposure time	0.001 ... 60000 ms

Acquisition formats

Image formats, interface frame rate max.	Full Frame, 2448 × 2048 px, max. 24 fps Binning 2×2, 1224 × 1024 px, max. 36 fps Binning 2×1, 1224 × 2048 px, max. 36 fps Binning 1×2, 2448 × 1024 px, max. 36 fps
Image formats, acquisition frame rate max. (Burst Mode)	Full Frame, 2448 × 2048 px, max. 36 fps
Pixel formats	Mono8 Mono10 Mono12 Mono12 Packed

Image preprocessing

Analog controls	Gain (0 ... 48 dB) Offset (0 ... 255 LSB 12 Bit)
Color models	Mono

Camera features

Basic Functions	Exposure Gain Trigger / Exposure Active (Flash) Binning 2x2 Partial Scan Offset Free Running Mode (Live Image)
Auto Functions	Exposure Auto Gain Auto
Image Pre-processing	Image Flipping (X/Y) LUT / Gamma
Acquisition / Interface	Burst Mode Adjustable Framerate Short Exposure Time Enable Device Link Throughput Limit Internal Image Buffer
Synchronization	free running trigger
Trigger sources	Hardware Software ActionCommand
Trigger delay	0 ... 2 sec, tracking and buffering of up to 256 trigger signals

VCXG-51M.I.XT

Gigabit Ethernet, 5,0 Megapixel, Monochrome

Article number: 11188955

Technical data

Camera features

Process Synchronization	<ul style="list-style-type: none"> Events Timer Trigger Delay Debouncer Counter Sequencer Trigger via Action CMD (GigE) Additional Output Modes (e.g. Trigger Ready) PWM (PWM Duration / PWM Duty Cycle) 4 power outputs with up to 120 W (max. 48 V / 2.5 A) Selectable Output format (e.g. Tri State, Push Pull) Chunk data inside transferred image Encoder support via Counter End trigger source
Additional Functions	<ul style="list-style-type: none"> User Set Integrated temperature sensor Readable additional information (e.g. sensor information) Save Custom Data
Internal image buffer	<ul style="list-style-type: none"> 115 MB 8 images (Trigger Mode) 1 image (Free Running Mode)

Interfaces and connectors

Data interface	Gigabit Ethernet, Transfer rate 1000 Mbits/sec, Fast Ethernet, Transfer rate 100 Mbits/sec, Connector: M12 / 8 pol x-coded, screwable type
Process interface	M12 / 12 pins a-coded (SACC-CI-M12MS-12CON-L180)
Power supply	via M12/12 pins a-coded or Power over Ethernet (PoE)

Mechanical data

Lens mount	C-mount
Width	40 mm
Height	40 mm
Depth	50.8 mm
Weight	≤ 137 g
Material	aluminum, hard-anodized

Electrical data

Voltage supply range +Vs	12 ... 24 V DC (external power supply) 36 ... 57 V DC (Power over Ethernet)
Power consumption	approx. 2,3 W @ 12 VDC and 24 fps approx. 3,1 W @ 48 VDC (PoE) and 24 fps

Non-volatile memory

Flash memory size	128 kB
-------------------	--------

Environmental conditions

Operating temperature	-40 ... +70 °C @ T = measurement point
Humidity	10 ... 90 % (non-condensing)
Protection class	IP 40 IP 54 (with mounted tube and cable) IP 65 (with mounted tube and cable) IP 67 (with mounted tube and cable) IP 69K (with stainless steel housing accessory)

Digital I/Os

Lines	4 input lines 4 power output lines with pulse width modulation (PWM) (max. 48 V / max. 2,5 A)
-------	--

Conformity

Conformity	CE RoHS KC (R-R-BkR-VCXG-51MI) EAC
------------	---

VCXG-51M.I.XT

Gigabit Ethernet, 5,0 Megapixel, Monochrome

Article number: 11188955

Dimension drawing

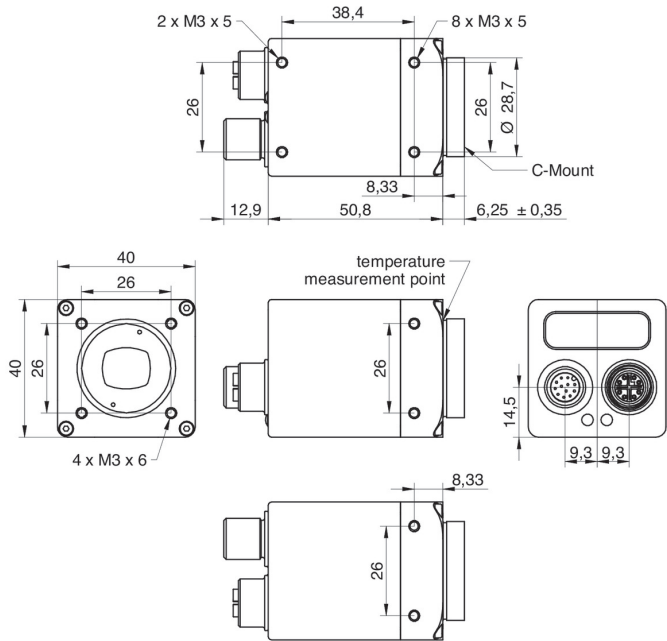

Principle

Optional accessories for protection class IP 65/67:

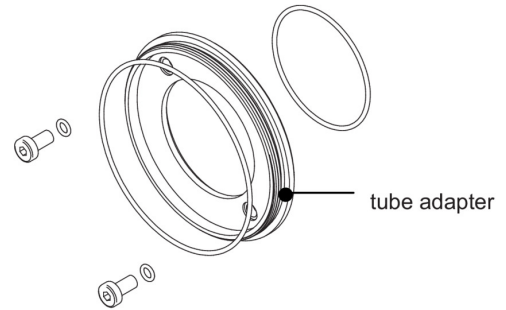

tube adapter

- hard-anodized, incl. sealing and screws
 Ø 49.5 mm (VCXG.I 11185373)
 Ø 65 mm (VCXG.I 11185377)
 Ø 65 mm (VLXT 11193125)

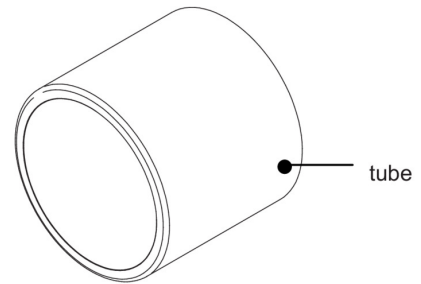

tube

- hard-anodized, cover glass PMMA
 Ø 49.5 mm, length 44 mm (11185370)
 Ø 65 mm, length 58 mm (11185374)
- hard-anodized, tempered laminated safety glass
 Ø 49.5 mm, length 44 mm (11701124)
 Ø 65 mm, length 58 mm (11701125)

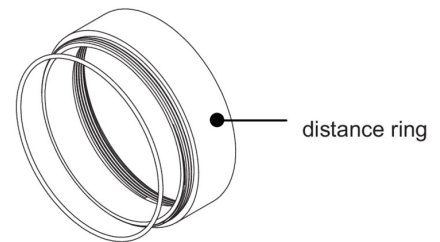

distance ring

- hard-anodized, incl. sealing
 Ø 49.5 mm, length 6 mm (11185372)
 Ø 49.5 mm, length 12 mm (11185371)
 Ø 49.5 mm, length 36 mm (11211571)
- Ø 65 mm, length 6 mm (11185376)
 Ø 65 mm, length 12 mm (11185375)
 Ø 65 mm, length 36 mm (111988906)

VCXG-51M.I.XT

Gigabit Ethernet, 5,0 Megapixel, Monochrome

Article number: 11188955

Principle

