

# Specification

## D-65A30-Kx/CXP-6

**Adimec**  
*Excellence in Imaging*

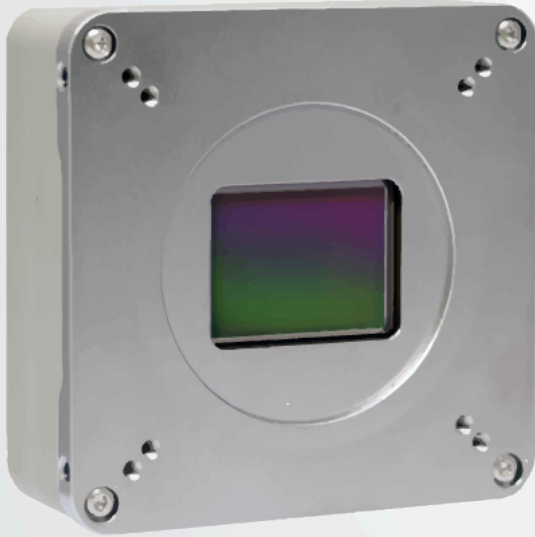

The D-65A30 is part of Adimec's DIAMOND Gentific™ camera series. The DIAMOND Gentific™ camera series are designed to offer an off the shelf solution for the most challenging in-line metrology and scientific healthcare image requirements.

The DIAMOND D-65A30 offers the next leap for ultra-high-resolution in-line display module inspection tools. It is optimized for LCD, OLED and MicroLED inspections. For De-Mura and display pixel calibration where multiple, very uniform, images are required, the D-65A30 combines 65 megapixel running up to 30 fps with a linear response. For Mura dark inspection the camera has superb sensitivity in combination with low noise performance at long exposure times without the need for active cooling.

The global shutter in combination with multi-exposure allows dark and bright inspection of LED-based displays without the need for complex mechanical and software system integrations to take care of the large difference in light conditions. With these functions and in combination with a 37mm optics and a high system throughput, the camera allows a cost effective display measurement.

The D-65A30 combines up to four CoaXPress connections to allow a throughput of 30 frames per second. Adimec Connect & Grab™ allows engineers to choose a variety of frame grabbers and start system development at camera arrival.

**CoaXPress**



9344 x 7000 at 30 fps



Pixel based dark field correction for all exposure times



Low frequency flat field correction in bright



Monochrome and color



Hirose 12pin I/O connector



CoaXPress V1.1.1

## Performance

Type	GPIXEL GMAX3265	
Architecture	CMOS progressive scan Global Shutter (PLS < 1/15000, angular dependent)	
Sensor diagonal	37.4 mm (29.9 x 22.4 mm)	
Pixel size	3.2 μm x 3.2 μm	
Active pixels	9344 (H) x 7000 (V)	
Microlenses	Yes	
	Maximum sensitivity for Mura dark	Maximum throughput for De-Mura
Dynamic range	59.7 dB** @ 12 bit - PGA gain 4	64.6 dB** (66 dB*) @ 12 bit - PGA gain 1.25
Full well	3 ke <sup>-**</sup> @ 12 bit - PGA gain 4	10.5 ke <sup>-**</sup> @ 12 bit - PGA gain 1.25
Dark noise	2.5 e <sup>-**</sup> @ 12 bit - PGA gain 4	5.2 e <sup>-**</sup> @ 12 bit - PGA gain 1.25
Sensitivity mono	268 DN <sub>12</sub> ·cm <sup>2</sup> /nJ @ 500 nm	

\* Sensor specification, \*\* Typical value

## Quantum Efficiency

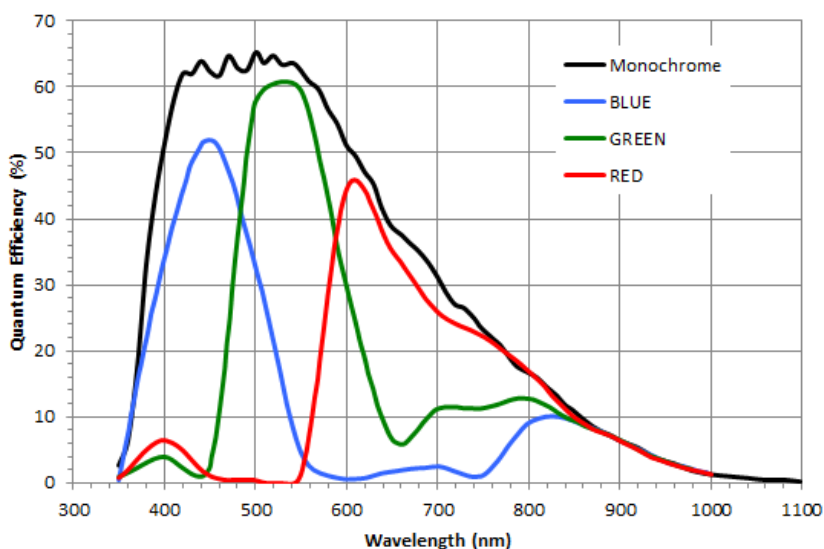

## Functionality

Image acquisition	Timed, TriggerWidth, SyncControl, TimedTriggerControl, TimedMultiExposure, TimedTriggerControlMultiExposure
Integration time control	Programmable between 9 μs and 5 s in steps of 1 μs
Multi-exposure mode	Multi-exposure image acquisition mode to avoid pixel saturation and to remove visible bands at short exposure times
Gain	Digital fine gain selectable between 1x and 32x in steps of 0.001 Programmable gain amplifier selectable between 0.75x and 6x in steps of 0.25
Video processing	Manual/One push White Balance - User programmable LUT - Programmable gamma curve
Region of interest	Programmable ROI; size and position of readout image - Increased frame speed via ROI - Digital binning
Defect pixel correction	On/Off switchable - Correction of clusters up to 3x3 pixels - Review and editing of defect pixel map - Factory calibrated
Uniformity correction	Up to 50 low frequency flat field correction sets can be saved in non-volatile memory (Mono only) - Up to 14 out of 50 can be live switched from frame to frame (Mono only) User calibratable pixel based dark field (DSNU) uniformity correction with temperature and exposure time compensation User calibratable column based bright field uniformity correction
Sensitivity Matching	Conversion gain calibrated per camera to achieve sensitivity matching between cameras
Test mode	Internal test pattern generator available to check the complete digital image chain
Mirroring	The output can be flipped in the horizontal and vertical direction
Miscellaneous functions	Programmable I/O polarity with deglitch function - 1 factory set and 10 user sets for storage of camera settings - Frame counter - Temperature readout - Camera type, build state and serial number can be read via software

## DSNU correction

	Available range for user calibrations
DSNU correction exposure time range	9 $\mu$ s - 5 s*
DSNU correction sensor temperature range	+/- 3°C around calibration temperature
*DSNU correction will correct for actual exposure time and is default calibrated at 1 s - 3 s	

## Interfacing

### Video

Video output	CoaXPress V1.1.1 CXP3/6 - 1, 2, 4 lanes configurable
External Sync	I/O or CXP controlled
Output resolution	8 / 10 / 12 bit
Connector	4 x DIN1.0/2.3

### Camera Control Protocol

Interface	GenICam (SFNC)*
Throughput	20 Mbps
Protocol	GenTL*
*Conform CoaXPress standard	

### I/O

Output	LVDS - Fully programmable flash strobe signal (duration, delay and polarity)
Input	LVDS - Trigger signal with programmable polarity
Connector	Hirose 12 pin HR10A-10R-12P(73)

### Power

Input voltage	24 Vdc nominal, range: 18.5 Vdc to 26 Vdc PoCXP
Power dissipation	< 13 W @ 24 Vdc full continuous operation at maximal framespeed
Power connector	DIN1.0/2.3 CoaXPress master connection

### Interface connectors

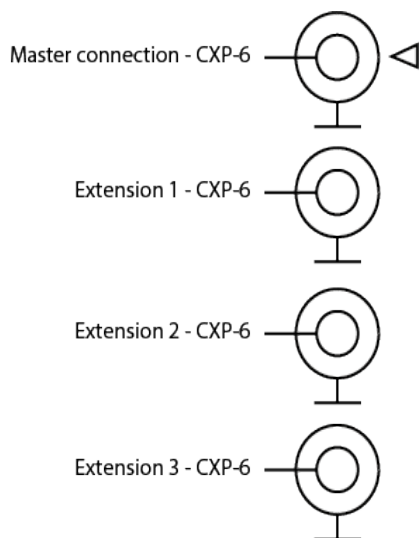

Figure 1. Quad CXP DIN1.0/2.3

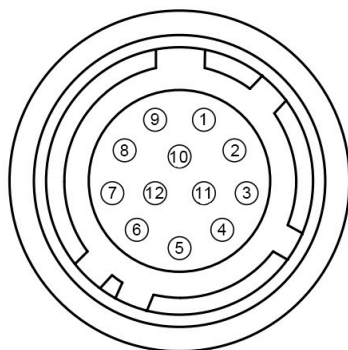

Figure 2. Hirose 12 pin HR10A-10R-12P(73) I/O connector

I/O pin connection table

1	Ground
2	Not in use
3	Flashstrobe out (-)
4	Flashstrobe out (+)
5	Not in use
6	Not in use
7	Not in use
8	Not in use
9	Ground
10	Not in use
11	Trigger in (-)
12	Trigger in (+)

# High Resolution Metrology Camera

## Mechanical

Mounting	2 x M4 mounting holes per side on camera front
Lensmount	4 x M3 at 60mm pitch - 4 x M3 at 54mm pitch - 50mm G7 reference (on request: F, TFL-II, T2, M42 )
Heatsink	4 x M3 at 70mm pitch on camera backplate (on request: Heatsink available)
Outline	See figure
Weight	400 g +/- 5% excl. lensmount and heatsink

## Mechanical outline

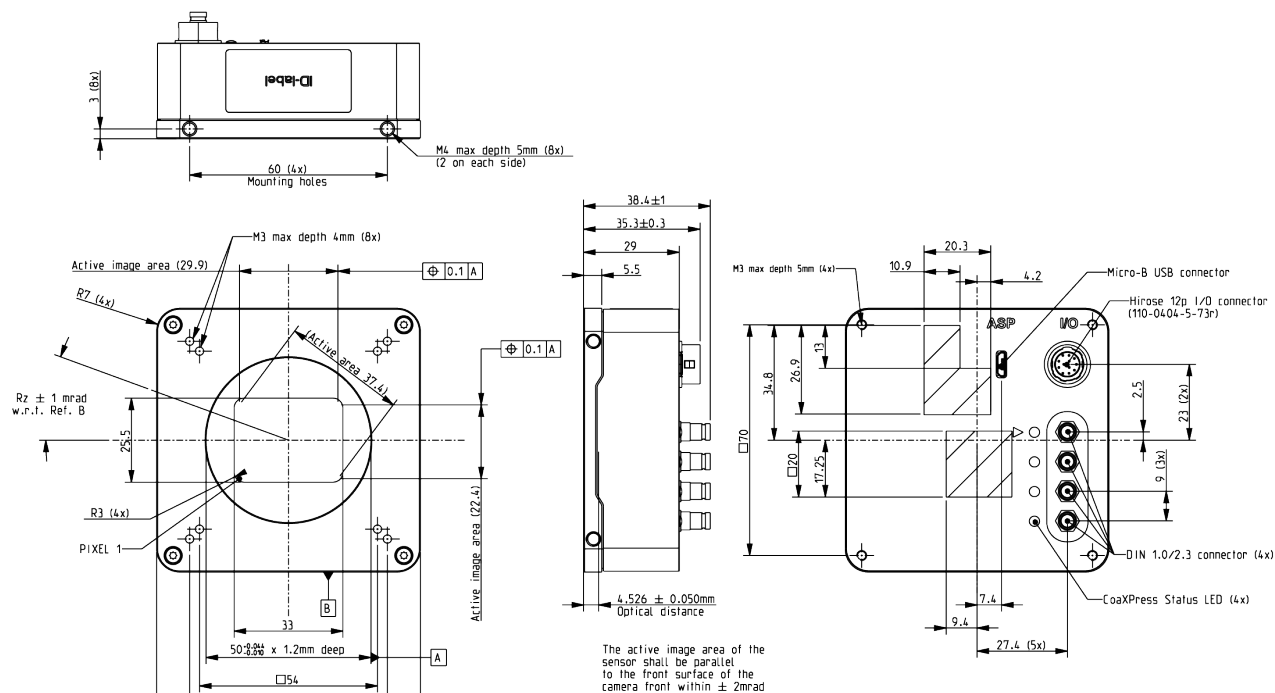

## Sensor Mounting Accuracy

XY-centering	$\pm 0.050$ mm
Rotation	$\pm 1$ mRad
Optical distance	$4.526 \pm 0.050$ mm
Perpendicularity	$\pm 2$ mRad

All specifications on the sensor alignment are with respect to the camera front without lensmount and lens

## Compliance

RoHS	RoHS directive 2011/65/EU (incl. amendment 2015/863)
Electromagnetic compatibility	2014/30/EU: EN61000-6-3 and EN61000-6-2
ESD	Contact discharge +/- 4 kV; Air discharge +/- 8 kV
Workmanship	In accordance with IPC-J-STD-001 class 2 and inspected according IPC-A-610 class 2

## Reliability

MTBF	> 75,000h @ 30 °C calculated according to the part stress analysis of MIL-HDBK-217F for ground fixed, uncontrolled environment
------	--

# High Resolution Metrology Camera

## Environmental

### Operating

Sensor temperature	+5 °C to +70 °C
Humidity (relative)	20% - 80% non-condensing
Shock	10 g, half sine shape, 6-10 ms duration in $\pm X$ , $\pm Y$ and $\pm Z$
Vibration	3 g sinusoidal vibration sweeps 5 - 150 Hz

### Storage

Ambient temperature	-25 °C to +65 °C
Humidity (relative)	5% - 95% non-condensing
Shock	25 g, half sine shape, 6-10 ms duration in $\pm X$ , $\pm Y$ and $\pm Z$
Vibration	10 g sinusoidal vibration sweeps 5 - 150 Hz

## Camera Types

Camera	Interface connector	I/O connector	Sensor	Type	Max. fps @ Full resolution
D-65A30-Km/CXP-6-1.1	4 x DIN1.0/2.3	Hirose 12 pin	GMAX3265 (monochrome)	Monochrome	30 fps
D-65A30-Kc/CXP-6-1.1	4 x DIN1.0/2.3	Hirose 12 pin	GMAX3265 (color)	Raw Bayer	30 fps

### Adimec

Adimec is the leading supplier of high-end cameras for machine vision, medical and outdoor imaging applications. Our Adimec True Accurate Imaging® technology forms the foundation for a broad range of camera products, and brings new levels of precision and accuracy to vision systems.

### Custom cameras

Adimec has the ability to offer additional camera functionality and create customer specific cameras even for small volume programs. Built from platforms, our standard line of cameras give us a flexible base that can be tailored to fit your specifications. Contact us to discuss these options in more detail. Visit: [www.adimec.com](http://www.adimec.com) for product details.



**For maximum image quality, performance, and reliability in demanding applications - Choose Adimec**

North America	Europe	Japan & Korea	Asia - Pacific	China
Phone: (+1)-781-279-0770	(+31)-40-2353900	(+81)3-5968-8377	(+65)-6334-1236	(+86)21-6266-1692
Fax: (+1)-781-279-0771	-	(+81)3-5968-8388	(+65)-6334-1436	-
E-mail: <a href="mailto:salesus@adimec.com">salesus@adimec.com</a>	<a href="mailto:saleseu@adimec.com">saleseu@adimec.com</a>	<a href="mailto:salesjp@adimec.com">salesjp@adimec.com</a>	<a href="mailto:salesap@adimec.com">salesap@adimec.com</a>	<a href="mailto:salescn@adimec.com.cn">salescn@adimec.com.cn</a>

Detailed information on request - Subject to change without notice - Actual products may differ from photos  
D-65A30-Kx/CXP-6 Revision 1.1

**Adimec**  
[www.adimec.com](http://www.adimec.com)