

CIS

**Camera Link I/F
VGA B/W Camera**

VCC-VCL3M

Product Specifications & Operational Manual

CIS Corporation

Table of Contents

	PAGE
1. Handling Precautions	2
2. Product Outline	3
3. System Configuration.....	3
3.1. Camera.....	3
3.2. Optional Accessories.....	3
3.3. Optional Function	3
3.4. Packaging	3
4. Specifications	4
4.1. General Specifications.....	4
4.2. Camera Input and Output Signals Specifications.....	5
4.3. CMOS Spectral Response	6
5. Function Settings	7
5.1. ROI and Frame Rate.....	10
5.2. Sub-sampling and Frame Rate	10
6. External Connector Pin Assignment	11
6.1. 6pins Circular Connector HR10-7R-6PA (HIROSE).....	11
6.2. 26pins Small Camera Link Connector 12226-1100-00 PL (SUMITOMO 3M)	11
7. Timing Chart.....	12
7.1. Horizontal Synchronous Timing	12
7.2. Vertical Synchronous Timing	13
7.3. Fixed Trigger Shutter Mode	13
7.4. Pulse Width Trigger Shutter Mode	14
7.5. Note for Trigger Shutter Mode.....	15
8. Serial Communication Function	16
9. Factory Settings	17
10. CMOS Optical Axis Accuracy	18
11. Dimensions	19
12. Cases for Indemnity (Limited Warranty).....	20
13. CMOS Pixel Defect.....	20
14. Product Support	20
15. Ordering Information.....	20

1. Handling Precautions

The camera must not be used for any nuclear equipments or aerospace equipments with which mechanical failure or malfunction could result in serious bodily injury or loss of human life. Our warranty does not apply to damages or defects caused by irregular and/or abnormal use of the product.

Please observe all warnings and cautions stated below.

Our warranty does not apply to damages or malfunctions caused by neglecting these precautions.

- Do not use or store the camera in the extremely dusty or humid places.
- Do not apply excessive force or static electricity that could damage the camera.
- Do not shoot direct images that are extremely bright (e.g., light source, sun, etc.), and when camera is not in use, put the lens cap on.
- Follow the instructions in Chapter 6, "External connector pin assignment" for connecting the camera. Improper connection may cause damages not only to the camera but also to the connected devices.
- Confirm the mutual ground potential carefully before connecting the camera to monitors or computers. Any AC leaks from the connected devices may cause damages or destroy the camera.
- Do not apply excessive voltage. (Use only the specified voltage.) Unstable or improper power supply voltage may cause damages or malfunction of the camera.
- The voltage ripple of camera power DC $+12V \pm 10\%$ shall be within $\pm 50mV$. Improper power supply voltage may cause noises on the video signals.
- The rising time of camera power supply voltage shall be less than $+10V$, Max 60ms. Please avoid noises like chattering when rising.

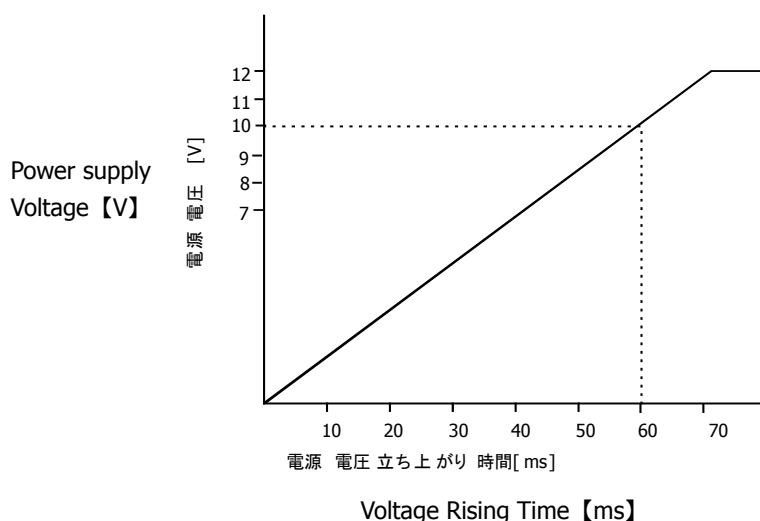

2. Product Outline

VCC-VCL3M is a Camera Link interfaced and VGA resolution, small industrial B/W video camera module. 0.3M pixels, 1/4 type CMOS sensor is utilized.

Features

- 29mm cubic in size
- Global shutter CMOS sensor
- Camera Link I/F
- ROI
- Sub-sampling
- External trigger

3. System Configuration

3.1. Camera

- Camera, VCC-VCL3M
- Lens cap

3.2. Optional Accessories

- None

3.3. Optional Function

- None

3.4. Packaging

- Individual carton
- Master carton (10pcs/carton)

Note) Master carton may vary depends on the quantity to be shipped.

4. Specifications

4.1. General Specifications

(1) Pickup device	Device Type	1/4 type Global Shutter CMOS Image Sensor	
	Effective pixel number	640(H) × 480(V)	
	Unit cell size	4.8μ m(H) × 4.8μ m(V)	
(2) Video output frequency	Pixel Clock	72.000 MHz	
	Frame rate	1Tap CL Clock 72MHz	133.8Hz
		2Tap CL Clock 36MHz	133.8Hz
		2Tap CL Clock 72MHz	267.7Hz ※2Tap 8Bit output (Factory setting)
3Tap CL Clock 72MHz		537.6Hz	
(3) Sync system	Internal Sync. System.		
(4) Video output	Camera Link / PoCL		
(5) Resolution	640 TV lines		
(6) Output format	8bit / 10bit		
(7) Sensitivity	F2.8 400 lx (Shutter speed 1/279s, Gain 0dB)	※2Tap 8Bit output (Factory setting)	
(8) Minimum illumination	F1.4 15lx (Shutter speed 1/279s, Gain+12dB)	※2Tap 8Bit output (Factory setting)	
(9) Dust or stains in optical system	No dust or stain shall be detected on the testing screen with setting the camera aperture at F11.		
(10) Power requirements	DC+12V±10%	※PoCL supported	
(11) Power consumption	Typ. 2.0W (at DC+12V IN) 2Tap 8Bit 72MHz ROI:OFF Gain: x1 Shutter:OFF		
(12) Dimensions	Refer to overall dimension drawing. (H:29mm W:29mm D:29mm excluding projection)		
(13) Weight	Approx. 50g		
(14) Lens mount	C Mount ※Refer to overall dimension drawing.		
(15) Optical axis accuracy	Refer to drawing for CMOS Optical Axis Accuracy.		
(16) Gain variable range	x1~x32	※image quality guaranteed range x1~x4	
(17) Shutter speed variable range	OFF(1/279s), 1/517s, 1/1069s, 1/2314s, 1/5524s, 1/10752s	※2Tap 8Bit output (Factory setting)	
(18) Trigger shutter mode	<ul style="list-style-type: none"> •Fixed Shutter Trigger Mode •Pulse Width Shutter Trigger Mode (Exposure time is set by the pulse width of the trigger signals.) 		
(19) Safety/Quality standards	UL: Conform to UL Standard including materials and others.		
	CE:	EN55022:2010 (Class A) for Emission EN61000-6-2:2005 for Immunity	
	RoHS:	Conform to RoHS.	
(20) Durability	Vibration	Acceleration	: 98m/s ² (10G)
		Frequency	: 20~200 Hz
		Direction	: X,Y, and Z 3 directions
		Testing time	: 120min for each direction
	Shock	No malfunction shall be occurred with 980m/s ² (100G) for ±X,±Y, and ±Z, 6 directions. (without package)	
(21) Operational environment	Temperature:	Performance guaranteed temperature: 0°C~+40°C Camera operation guaranteed temperature: -5°C~+45°C	
	Humidity:	RH 20~80% with no condensation.	
	※All the specifications specified in this manual is guaranteed under performance guaranteed temperature. ※All the camera functions operate normally under operation guaranteed temperature.		
(22) Storage environment	Temperature:	-25°C~+60°C	
	Humidity:	RH 20~80% with no condensation.	

4.2. Camera Input and Output Signals Specifications

(1) Video output data	Effective Video Output	1280(H) x 1024(V)	At full frame scan mode
(2) Sync. Signal input and output	FVAL output	LVDS	Camera Link connector
	LVAL output	LVDS	
	DVAL output	LVDS	
	EEN output	Open collector	6pins Circular connector
	Trigger Input	Photo Coupler	
(3) Trigger Input	The minimum width of the trigger pulse	Within 110μ S ~ 45mS	
	Camera Link Input	LVDS : CC1 input	Camera Link connector
	TTL input		6pins Circular connector

【Reference】 Trigger IN terminal of 6pins circular connector for external control is electronically insulated. Trigger IN terminal (TRIG_IN in the drawing below) shall be capable for 10mA~20mA current. And, EEN OUT terminal (EEN_OUT in the drawing below) needs power (3.3V ~ 20V) so that 0.5mA~5mA shall be added for load resistance.

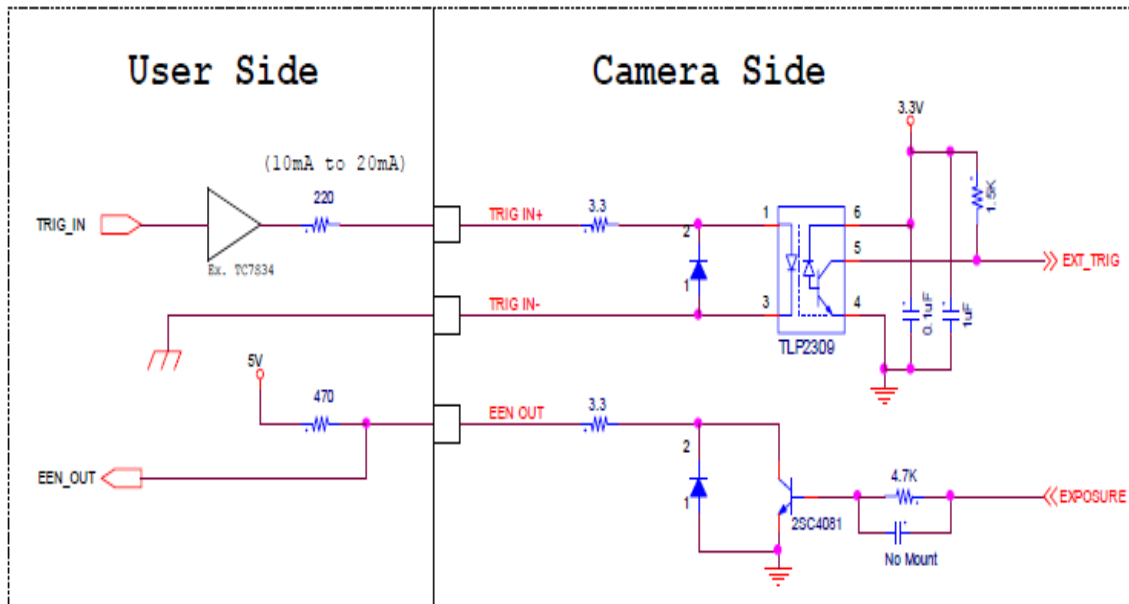

※3 seconds shall be waited after turning on power to get proper camera operation.

4.3. CMOS Spectral Response

※The lens characteristics and illuminant characteristics are excluded.

Spectral Response Curve

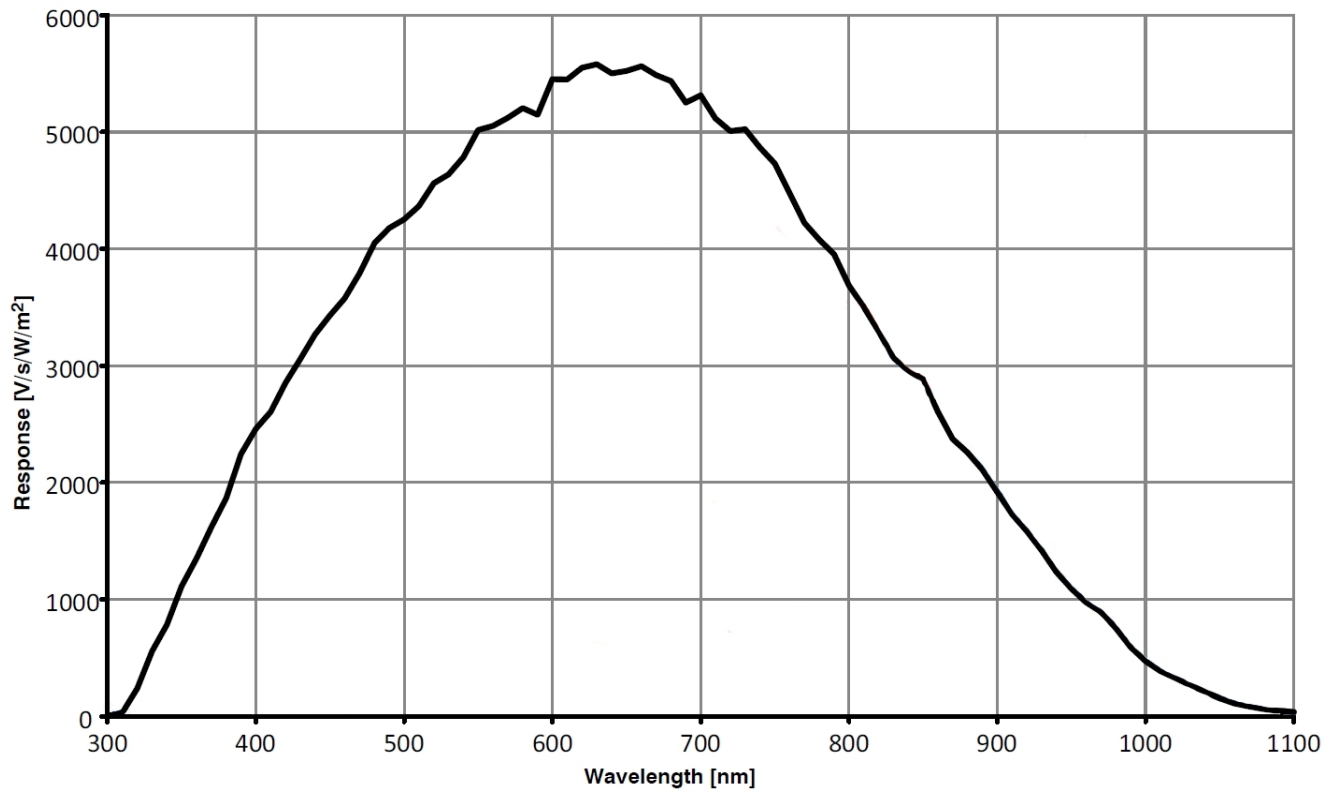

5. Function Settings

(Camera functions can be set with serial communications.)

Function	Address	Data				
Output bit length and tap width	2	0: 1Tap 8bit Output CLK:72MHz 640 (H)×480 (V)				
		1: 1Tap 10bit Output CLK:72MHz 640 (H)×480 (V)				
		2: 2Tap 8bit Output CLK:36MHz 320×2Tap(H)×480(V)				
		3: 2Tap 10bit output CLK:36MHz 320×2Tap(H)×480(V)				
		4: 2Tap 8bit Output CLK:72MHz 320×2Tap(H)×480(V)				
		5: 2Tap 10bit output CLK:72MHz 320×2Tap(H)×480(V)				
		6: 3Tap 8bit Output CLK:72MHz 212×3Tap(H)×480(V)				
Trigger shutter mode	3	0: Normal shutter mode (Trigger shutter mode OFF)				
		1: Fixed trigger shutter mode (Shutter speed can be set with address 23.)				
		2: Pulse width trigger shutter mode (Shutter speed can be set with trigger pulse width.)				
Trigger input settings	4	0: Camera Link CC1 Positive polarity input				
		1: Camera Link CC1 Negative polarity input				
		2: 6pin Connector Trig + Positive polarity input				
		3: 6pin Connector Trig + Negative polarity input				
		4: 6pin Connector Trig - Positive polarity input				
		5: 6pin Connector Trig - Negative polarity input				
Black level control values	7	0~15: Output black level (8bit) = (setting value) Factory setting Output black level (10bit) = (setting value) x 4				
Defective pixel correction	13	0: Defective pixel correction OFF				
		1: Defective pixel correction ON				
Gain control mode	20	0: 0dB X1 Factory setting				
		1: 3.5dB X1.5				
		2: 6dB X2				
		3: 9.5dB X3				
		4: 12dB X4				
		5: 15.5dB X6				
		6: 18dB X8				
		15: Manual gain control (Gain can be set with address 21.)				
Manual gain control	21	0~124: 0~30dB				
Shutter time settings	23	At normal shutter mode				
		1Tap & 2Tap 36MHz				
			ROI_0	ROI_1	ROI_2	SUB
		0:	1/139s	1/158s	1/317s	1/376s
		1:	1/534s	1/533s	1/535s	1/522s
		2:	1/1154s	1/1152s	1/1153s	1/1093s
		3:	1/2752s	1/2660s	1/2662s	1/2413s
		4:	1/4229s	1/4228s	1/4228s	1/4229s
		5:	1/11560s	1/11568s	1/11560s	1/11560s
		15: Manual shutter control (Manual shutter can be set with the address 24.)				

Function	Address	Data				
Shutter time settings	23	2Tap				
		ROI_0	ROI_1	ROI_2	SUB	
		0:	1/279s	1/319s	1/675s	1/735s
		1:	1/517s	1/517s	1/675s	1/735s
		2:	1/1069s	1/1066s	1/1070s	1/1044s
		3:	1/2309s	1/2304s	1/2306s	1/2187s
		4:	1/5505s	1/5321s	1/5325s	1/4831s
		5:	1/10727s	1/10723s	1/10727s	1/10727s
		15:	Manual shutter control (Manual shutter can be set with the address 24.)			
		3Tap	ROI_0	ROI_1	ROI_2	SUB
		0:	1/566s	1/638s	1/1326s	1/1495s
		1:	1/566s	1/638s	1/1326s	1/1495s
		2:	1/1032s	1/1032s	1/1326s	1/1495s
		3:	1/2143s	1/2138s	1/2133s	1/2088s
		4:	1/4576s	1/4572s	1/4575s	1/4375s
		5:	1/15048s	1/14923s	1/10405s	1/12610s
		15:	Manual shutter control (Manual shutter can be set with the address 24.)			
		At trigger shutter mode (Non-overlapped)				
		1Tap & 2Tap36MHz		2Tap		3Tap
		0:	1/137s	1/274s		1/556s
		1:	1/503s	1/501s		1/501s
		2:	1/1014s	1/1007s		1/1004s
		3:	1/2057s	1/2028s		1/2016s
4:	1/4237s	1/4115s		1/4065s		
5:	1/11627s	1/10725s		1/10416s		
15:	Manual shutter control (Manual shutter can be set with the address 24.)					
Manual shutter control	24	1Tap & 2Tap 36MHz	11~710	Set value (16bit) x 10us -13.6 μ s		
		2Tap	11~710	Set value (16bit) x 10us -6.8 μ s		
		3Tap	11~365	Set value (16bit) x 10us - 3.4 μ s		
ROI	50	0:	640 (H) x 480 (V)		At 3Tap ⇒ 636 (H) x 480 (V)	
		1:	512 (H) x 480 (V)		At 3Tap ⇒ 510 (H) x 480 (V)	
		2:	320 (H) x 240 (V)		At 3Tap ⇒ 318 (H) x 240 (V)	
Sub-sampling mode	56	0:	Sub-sampling OFF 640(H) x 480(V)		At 3Tap ⇒ 636 (H) x 480 (V)	
		1:	Sub-sampling ON 320(H) x 240(V)		At 3Tap ⇒ 318 (H) x 240 (V)	

※Note). At normal shutter mode, the followings shall be carefully considered with manual shutter control.

1 Tap & 2 Tap (36MHz)

ROI Setting	Manual Shutter Setting Value	Formula for Long Exposure Time
640 (H) x 480 (V)	11~34	Setting Value (16bit) x 10us -13.6μ s
512 (H) x 480 (V)	11~36	
320 (H) x 240 (V)	11~44	
Sub-sampling mode	11~30	

ROI Setting	Manual Shutter Setting Value	Formula for Long Exposure Time
640 (H) x 480 (V)	35	328.4μ s
512 (H) x 480 (V)	37	349.0μ s
320 (H) x 240 (V)	45	433.4μ s
Sub-sampling mode	Refer to the chart below.	Refer to the chart below.

ROI Setting	Manual Shutter Setting Value	Formula for Long Exposure Time
640 (H) x 480 (V)	36~710	Setting Value x 10us – 124.4μ s
512 (H) x 480 (V)	38~645	Setting Value x 10us – 124.4μ s
320 (H) x 240 (V)	46~315	Setting Value x 10us – 124.4μ s
Sub-sampling mode	31~275	Setting Value x 10us – 79.9μ s

(There is a minus jitter for 1H with the calculated value).

2Tap

ROI Setting	Manual Shutter Setting Value	Formula for Long Exposure Time
640 (H) x 480 (V)	11~17	Setting Value (16bit) x 10us – 6.8μ s
512 (H) x 480 (V)	11~18	
320 (H) x 240 (V)	11~22	
Sub-sampling mode	11~20	

ROI Setting	Manual Shutter Setting Value	Formula for Long Exposure Time
640 (H) x 480 (V)	—	Refer to the chart below.
512 (H) x 480 (V)	—	Refer to the chart below.
320 (H) x 240 (V)	—	Refer to the chart below.
Sub-sampling mode	21	200.5μ s

ROI Setting	Manual Shutter Setting Value	Formula for Long Exposure Time
640 (H) x 480 (V)	18~365	Setting Value x 10us – 62.2μ s
512 (H) x 480 (V)	19~320	Setting Value x 10us – 62.2μ s
320 (H) x 240 (V)	23~155	Setting Value x 10us – 62.2μ s
Sub-sampling mode	22~140	Setting Value x 10us – 39.9μ s

(There is a minus jitter for 1H with the calculated value).

3Tap

ROI Setting	Manual Shutter Setting Value	Formula for Long Exposure Time
640 (H) x 480 (V)	—	Refer to the chart below.
512 (H) x 480 (V)	—	Refer to the chart below.
320 (H) x 240 (V)	11	105.7s.
Sub-sampling mode	—	Refer to the chart below.

ROI Setting	Manual Shutter Setting Value	Formula for Long Exposure Time
640 (H) x 480 (V)	11~180	Setting Value x 10us – 31.1μ s
512 (H) x 480 (V)	11~160	Setting Value x 10us – 31.1μ s
320 (H) x 240 (V)	12~79	Setting Value x 10us – 31.1μ s
Sub-sampling mode	11~69	Setting Value x 10us – 20.0μ s

(There is a minus jitter for 1H with the calculated value).

5.1. ROI and Frame Rate

Setting modes	Output conditions and the corresponding frame rate			
		1Tap	2Tap	3Tap
ROI 0 (ROI OFF)	Pixel number	640 x 480	640 x 480	636 x 480
	Frame rate	133.8fps	267.7fps	537.6fps
	Entire CLK count for 1Line	952 CLK	476 CLK	238 CLK
ROI 1	Pixel number	512 x 480	512 x 480	510 x 480
	Frame rate	150.6fps	301.3fps	604.0fps
	Entire CLK count for 1Line	824 CLK	412 CLK	206 CLK
ROI 2	Pixel number	320 x 240	320 x 240	318 x 240
	Frame rate	299.8fps	599.6fps	1203.0fps
	Entire CLK count for 1Line	632 CLK	316 CLK	158 CLK

5.2. Sub-sampling and Frame Rate

Setting mode	Output conditions and the corresponding frame rate			
		1Tap	2Tap	3Tap
Sub-sampling OFF	Pixel number	640 x 480	640 x 480	318 x 480
	Frame rate	133.8fps	267.7fps	537.6fps
	Entire CLK count for 1Line	952 CLK	476 CLK	238 CLK
Sub-sampling ON	Pixel number	320 x 240	320 x 240	318 x 240
	Frame rate	340.0fps	654.7fps	1364.6fps
	Entire CLK count for 1Line	632 CLK	316 CLK	158 CLK

6. External Connector Pin Assignment

6.1. 6pins Circular Connector HR10-7R-6PA (HIROSE)

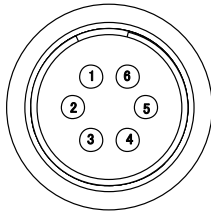
HR10-7R-6PA
(HIROSE)

Pin No.	Signal Name	Description
1	Power IN	non-PoCL: Power Input (DC 12V typical)
2	NC	Not used
3	EEN OUT	Exposure Enable Output (Open Collector)
4	Trigger IN-	Trigger Input- (Isolated)
5	Trigger IN+	Trigger Input+ (Isolated)
6	GND	GND (for Pin 1)

6.2. 26pins Small Camera Link Connector 12226-1100-00 PL (SUMITOMO 3M)

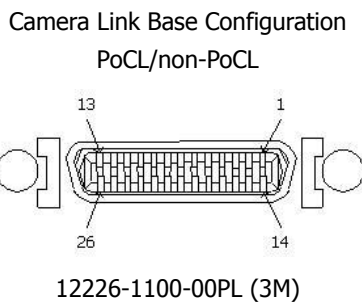

Pin No.	Signal Name	Description
1,26	Power IN or GND	PoCL : DC 12V Power Input non-PoCL: GND
13,14	GND	GND
2,15	X0-, X0+	X0_OUT0 differential pair for transmission
3,16	X1-, X1+	X1_OUT1 differential pair for transmission
4,17	X2-, X2+	X2_OUT2 differential pair for transmission
5,18	Xclk-, Xclk+	CLK OUT differential pair for transmission
6,19	X3-, X3+	X3_OUT3 differential pair for transmission
7,20	SerTC+, SerTC-	RXD Input differential pair for reception
8,21	SerTFC-, SerTFC+	TXD Output differential pair for transmission
9,22	CC1-, CC1+	Trigger Input differential pair for reception
10,23	CC2+, CC2-	Reserve differential pair for reception
11,24	CC3-, CC3+	Not used
12,25	CC4+, CC4-	Not used

※Never supply power via both 6pins circular connector and 26pins small Camera Link connector at the same time.
It may cause malfunction of the camera.

7. Timing Chart

7.1. Horizontal Synchronous Timing

1Tap output

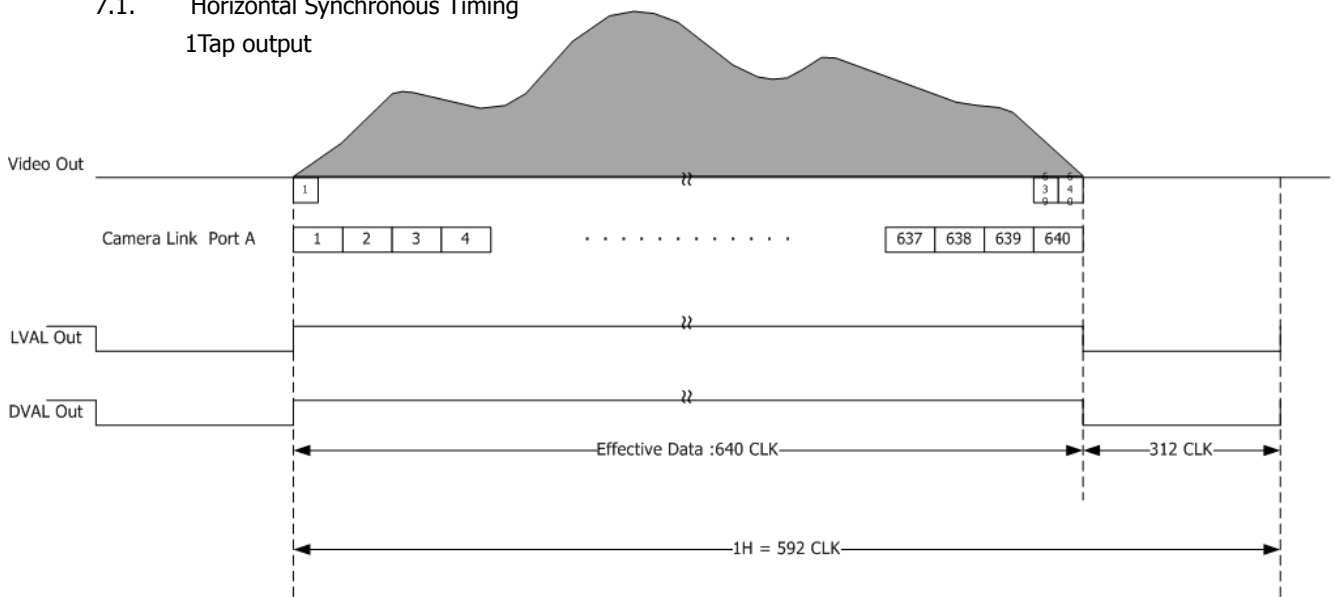

2Tap output

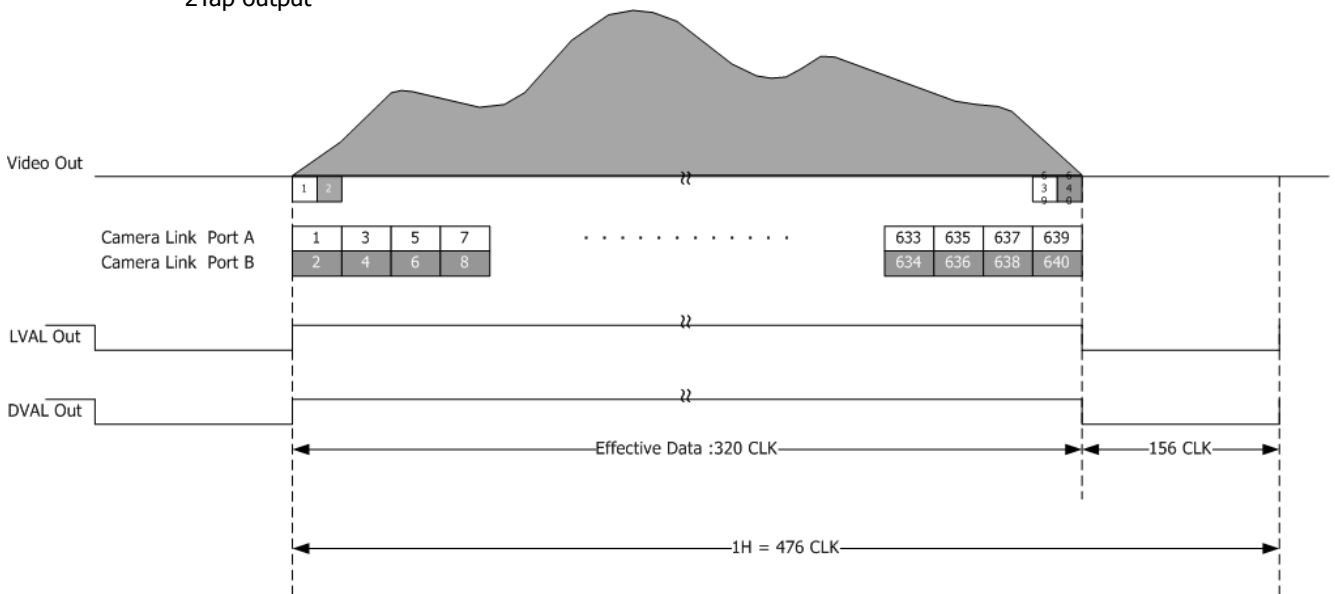

3Tap output

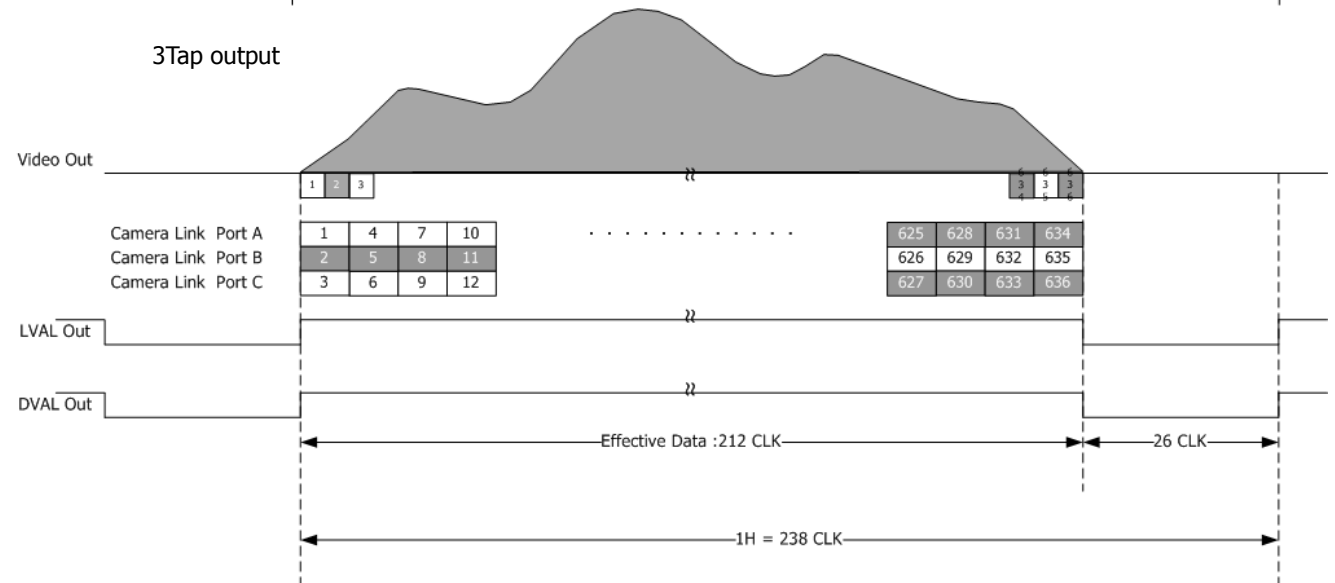

7.2. Vertical Synchronous Timing

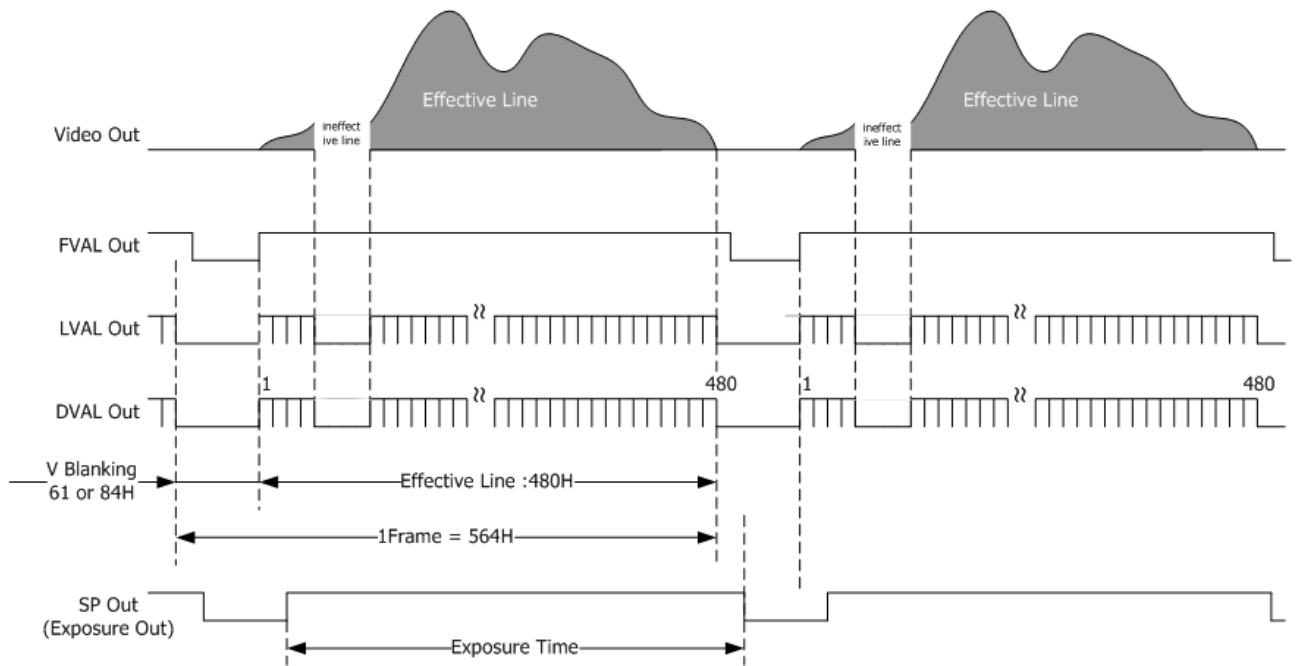

7.3. Fixed Trigger Shutter Mode

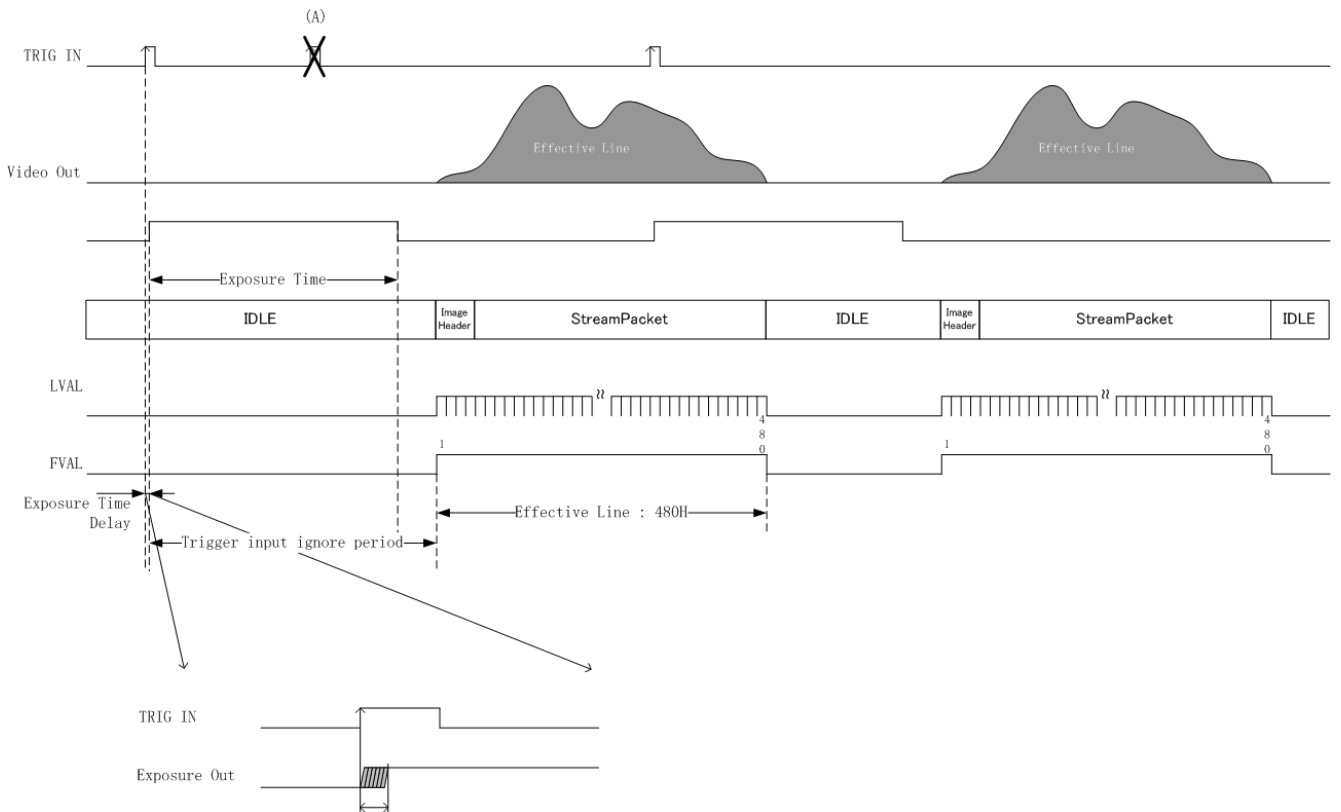

- 1Tap: 13.72μS delay
- 2Tap: 6.89μS delay
- 3Tap: 3.51μS delay

7.4. Pulse Width Trigger Shutter Mode

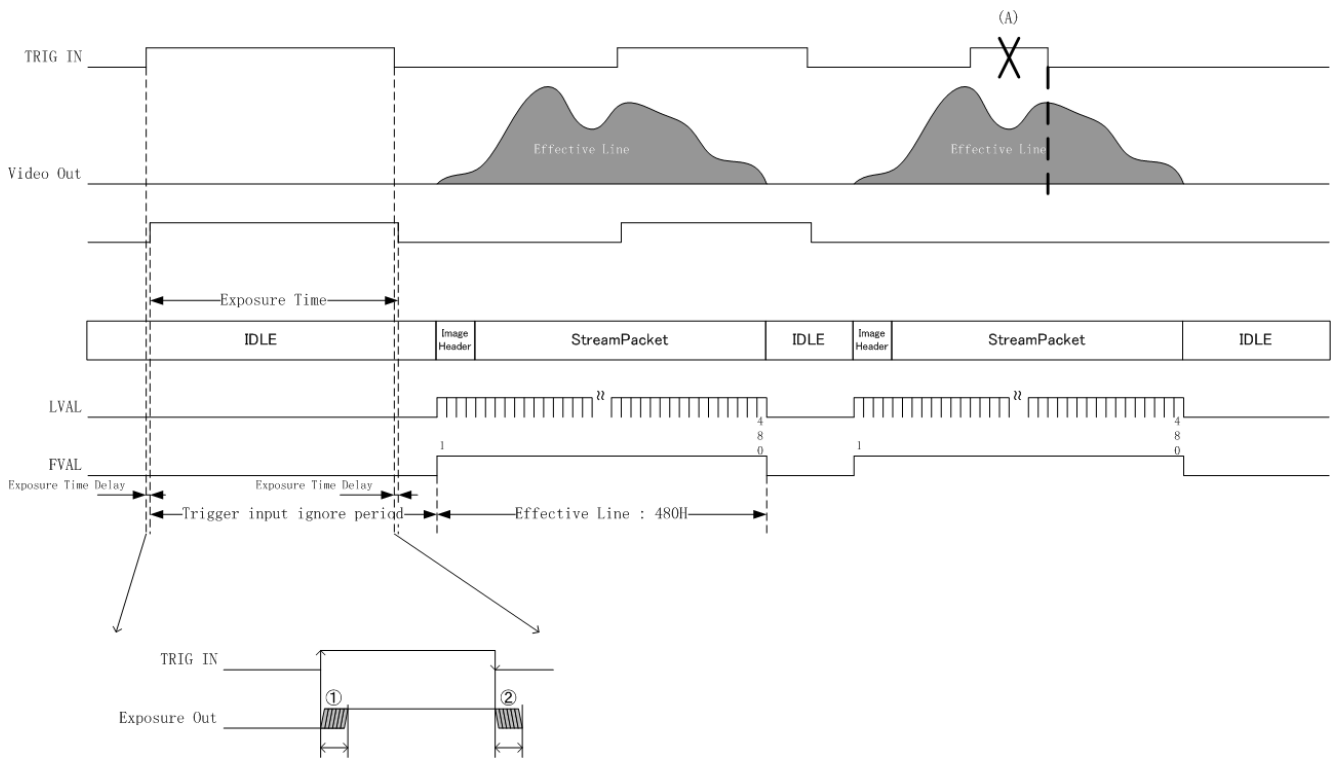

※The minimum pulse width 110µs

①

- 1Tap: 13.72µS delay
- 2Tap: 6.89µS delay
- 3Tap: 3.51µS delay

②

- 1Tap: 198nS delay
- 2Tap: 138nS delay
- 3Tap: 116nS delay

7.5. Note for Trigger Shutter Mode

- ① When the camera is initialized with trigger mode, dummy trigger signals shall be input 3times and more to make the operation of CMOS stable.
- ② At trigger shutter mode, if the next trigger is input with a timing to complete exposure within 3H after FVAL became "L", the camera may stop outputting its images. When the camera stops operating, or when proper image data cannot be output, send "SRST" command to re-start the camera.
 - ※ There is a case that output images become black (black out).

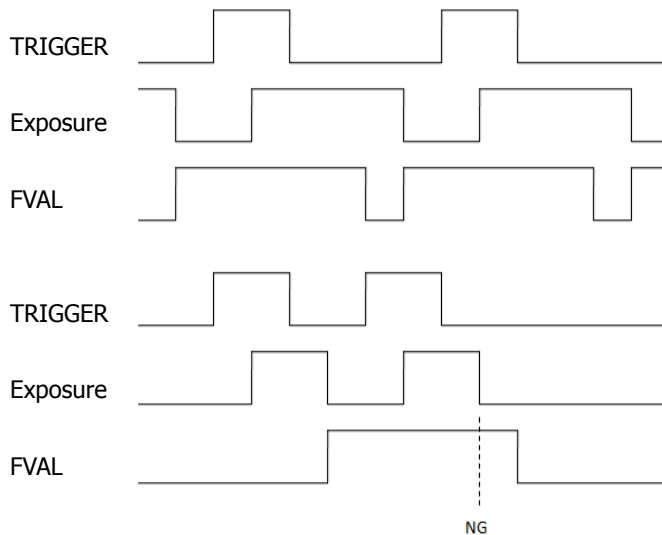

- ③ At trigger shutter mode, please be carefully noted the reduction of exposure time when the next trigger is overlapped. Refer to the Notes for Manual shutter control at normal shutter mode in the Section 5. Function Settings.
- ④ The next trigger during exposure time shall not be input like (A) in the timing chart of the Section 7.3. The exposure of the next trigger shall not end while reading out the prior images like (A) in the timing chart of the Section 7.4. (The next exposure can be started while reading out the prior images).
- ⑤ Do not change the output Tap at trigger shutter mode. Change the mode to normal shutter mode first to change output Tap.
- ⑥ Ineffective lines occur when exposure starts during outputting images at trigger mode. (Refer to the timing chart for vertical sync timing in the Section 7.2.).

8. Serial Communication Function

The camera can be controlled externally via Camera Link serial communication function.

(1) The settings for RS232C

Baud rate : 115200bps or 9600bps
 Data : 8bit
 Stop bit : 1bit
 Parity : None
 XON/XOFF : No control

(2) Control code

- The control code is ASCII code.
- The Camera setting data (including changes made) can be obtained by executing commands such as command, parameter, and CR (0x0d) or LF (0x0a) from PC to the Camera.

Command	Parameter 1	Parameter 2~7	Function
GU	Address	not used	Obtain a setting data
SU	Address	Data	Change a camera setting
SRST	not used	not used	Reset the sensor (Refer to the Section 7.5. ②).
INIT	not used	not used	Restore to the initial settings
SAVE	not used	not used	Save the settings to the camera.
GSI	not used	Data	Camera information received Data 1: Model name

(3) How to set a Command

{Command Name} {Parameter 1} {Parameter 2} {Parameter 3}...

- Input {Parameter n}
 - With hexadecimal notation.
 - Start inputting with "0x" or "0X".
 - Case-insensitive (Either a~f or A~F can be input).
 - Input range: 0x0000~0xFFFF
 - With decimal notation.
 - Only "0" ~ "9" can be input.
 - Input range: 0~65535
- At initialization, Prompt ">" is indicated after command is processed.
- Input command in capital letters following to the Prompt.
- Letters can be input up to 80 characters.
- Separate between a command and a parameter by one space.
- From the head of input character to the linefeed code CR (0x0d) or LF (0x0a) is analyzed as one command.
- Refer to the Section 5., Function Settings, for the detailed settings of address and data.
- The command from the PC will be received by the camera, and then echoed back.

【Example for Get Command】

To get the information of the address 10

[Send] GU[sp]10[¥r] or[¥n]

[Returned value] 50[¥r] [¥n] [Acquired data + Linefeed]

[Returned value] [¥r] [¥n] [Linefeed]

[Returned value] >[sp] [Prompt + Space]

【Example for Set Command】

To set 30 to the address 10

[Send] SU[sp]10[sp]30[¥r]or[¥n]

[Returned value] [¥r] [¥n] [Linefeed]

[Returned value] >[sp] [Prompt + Space]

【Example for SAVE Command】

[Send] SAVE[¥r]or[¥n]

[Returned value] [¥r] [¥n] [Linefeed]

[Returned value] >[sp] [Prompt + Space]

[¥r]=CR(0x0D)

[¥n]=LF(0x0A)

[sp]=Space(0x20)

9. Factory Settings

Function	Address	Data												
Output bit length and Tap width	2	4: 2Tap 8bit Output ※ CLK:72MHz 320 x 2Tap (H) x 480(V)												
Trigger shutter mode	3	0: Normal shutter mode (Trigger shutter mode OFF)												
Trigger input settings	4	0: Camera Link CC1 ※Input Polarity positive												
Black level control value	7	0: Output black level (8bit) = (Setting value)												
Defective pixel correction	13	1: Defective pixel correction ON												
Gain control mode	20	0: X1												
Manual gain control	21	0: X1												
Shutter time settings	23	At normal shutter mode												
		At trigger shutter mode												
		<table border="1"> <thead> <tr> <th></th> <th>1Tap & 2Tap 36MHz</th> <th>2Tap</th> <th>3Tap</th> <th>1Tap & 2Tap 36MHz</th> <th>2Tap</th> <th>3Tap</th> </tr> </thead> <tbody> <tr> <td>0:</td> <td>1/139s</td> <td>1/279s</td> <td>1/566s</td> <td>1/137s</td> <td>1/274s</td> <td>1/556s</td> </tr> </tbody> </table>		1Tap & 2Tap 36MHz	2Tap	3Tap	1Tap & 2Tap 36MHz	2Tap	3Tap	0:	1/139s	1/279s	1/566s	1/137s
	1Tap & 2Tap 36MHz	2Tap	3Tap	1Tap & 2Tap 36MHz	2Tap	3Tap								
0:	1/139s	1/279s	1/566s	1/137s	1/274s	1/556s								
Manual shutter control	24	11	1Tap & 2Tap 36MHz	96µ s										
		:	2Tap	103.2µ s										
			3Tap	76.3µ s										
ROI	50	0: 640 (H) x 480 (V) At 3Tap ⇒ 636 (H) x 480 (V)												
Sub-sampling mode	56	0: 640 (H) x 480 (V) At 3Tap ⇒ 636 (H) x 480 (V)												

10. CMOS Optical Axis Accuracy

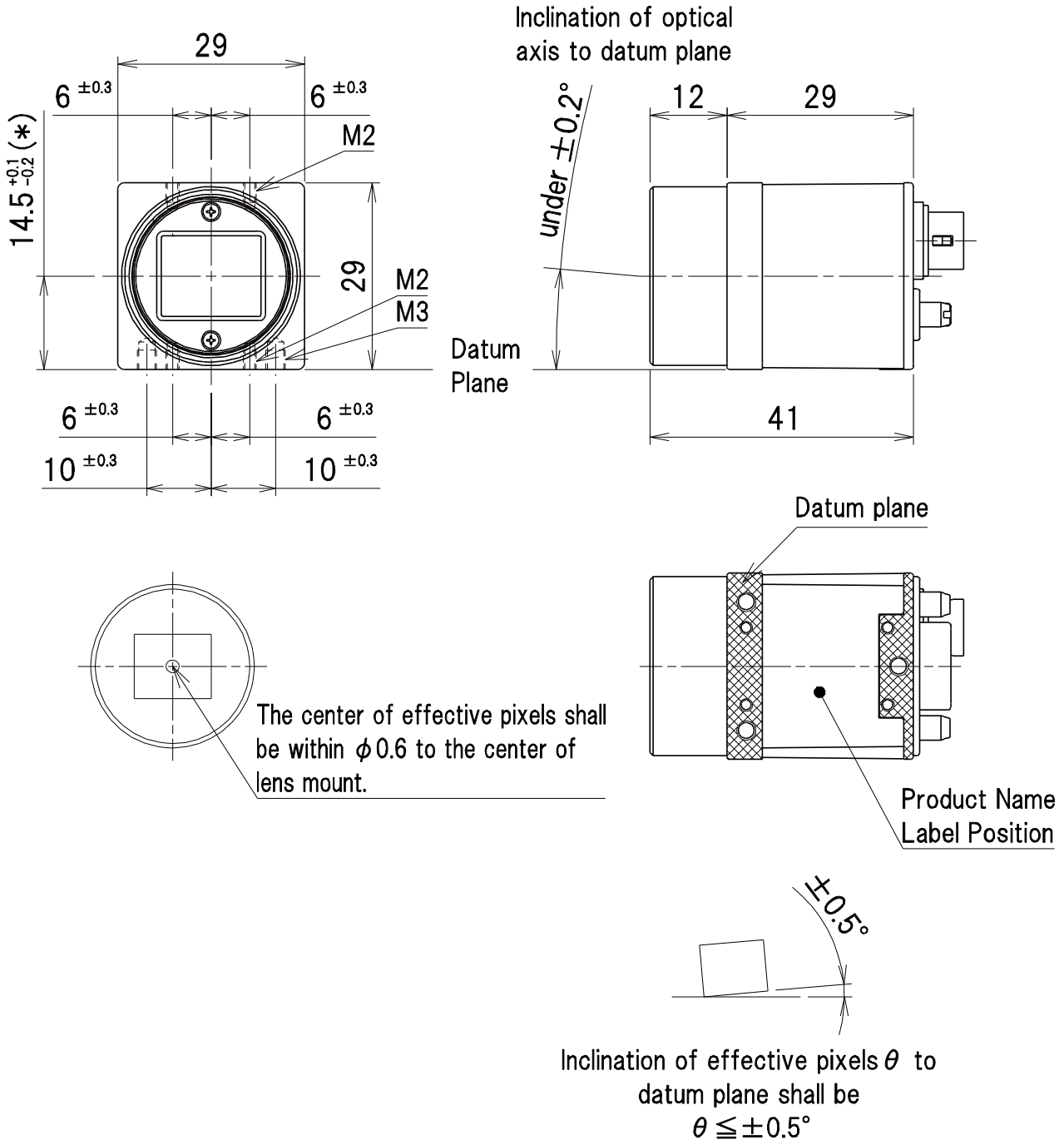

(*)Dimension from datum plane to the center of lens mount.

937-0009-01
(Unit:mm)

11. Dimensions

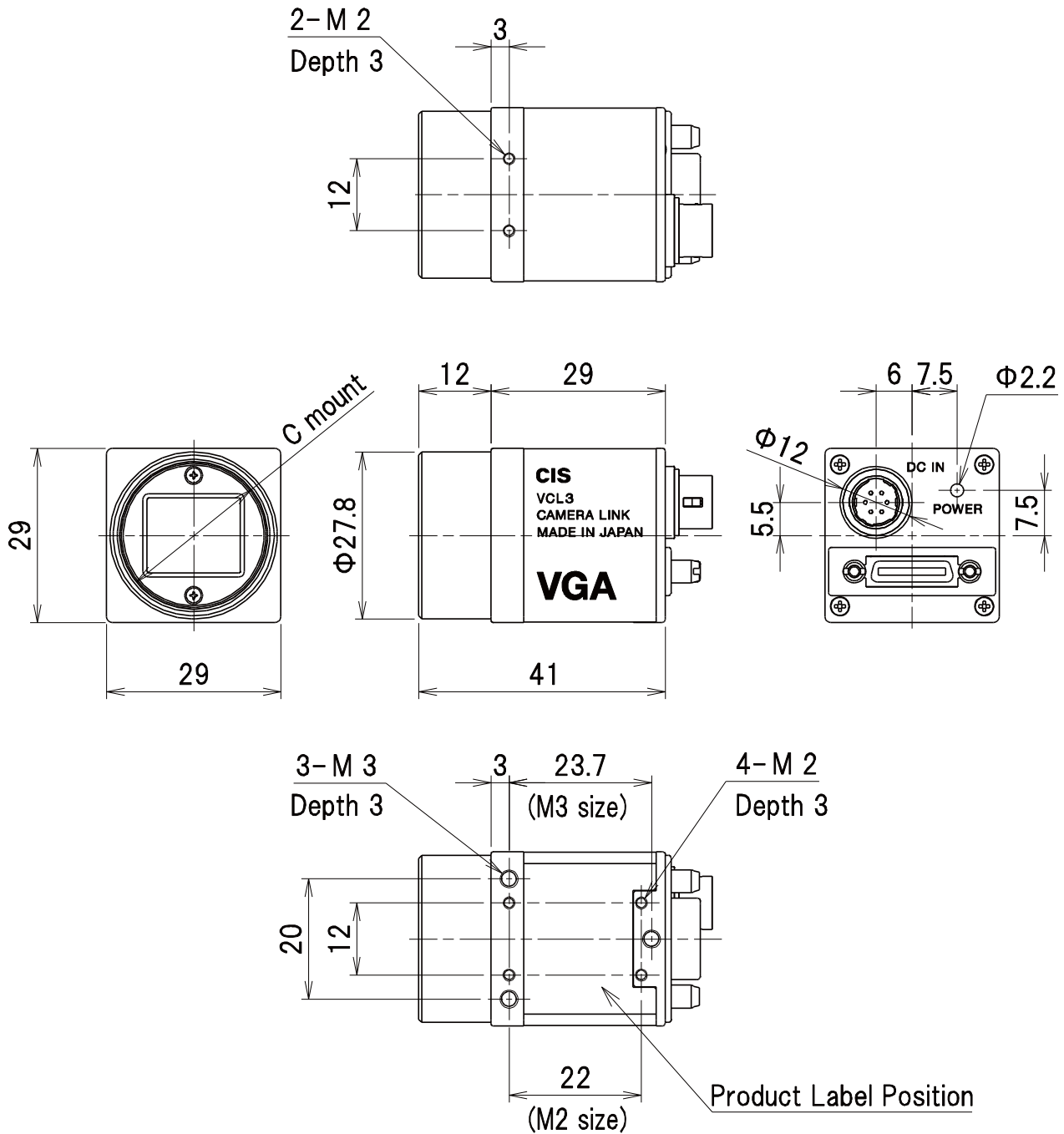

2) C mount screws comply with ANSI/ASME B1.1, 1-32UN(2B).

1) Screw length from the lens mount surface shall be less than 6mm. And protruding portion of the C mount lens shall be less than 10mm.

935-0040-00
(Unit:mm)

12. Cases for Indemnity (Limited Warranty)

The term of warranty of this product is within 3 years from the date of shipping out from our factory.

If you use the product properly and discover a defect during the warranty period, and if that was caused by designing or manufacturing, CIS Corporation, at its option, repairs or replaces it at no charge to you. Products out of warranty period will be subject to charge. CIS repairs the products as long as it is repairable.

CIS shall be exempted from taking responsibility and held harmless for damages or losses incurred by the following cases.

- In case damages or losses are caused by earthquake, lightning strike, fire, or other acts of God.
- In case damages or losses are caused by deliberate or accidental misuse by the user, or failure to observe the information contained in the instructions in this Product Specification and Operational Manual.
- In case damages or losses are caused by repair or modification conducted by the customer or any unauthorized party.

13. CMOS Pixel Defect

CIS compensates the noticeable CMOS pixel defects found at the shipping inspection prior to our shipment. On very rare occasions, however, CMOS pixel defects might be noted with time of usage of the products.

Cause of the CMOS pixel defects is the characteristic phenomenon of CMOS sensor itself and CIS is exempted from taking any responsibilities for them. Should you have any questions on CMOS pixel defects compensation, please contact us.

14. Product Support

Should you have any problems in function of the product you purchased, and if you need our further analysis and/or repair, please contact your distributors you purchased from.

15. Ordering Information

Serial communication speed to control camera is selectable at the factory.

Model name	Baud rate (bps)
VCC-VCL3M-1	115,200
VCC-VCL3M-9	9,600