

# CIS

**CoaXPress I/F  
2M CMOS B/W Camera**

# **VCC-2CXP6M**

## **Product Specifications & Operational Manual**

**CIS Corporation**

## Table of Contents

1.	Handling Precautions .....	1
1.1.	Camera Handling Precautions.....	1
1.2.	Restrictions on Applications.....	1
1.3.	Disclaimers (Exception Clause).....	1
2.	Product Outline .....	2
2.1.	Features.....	2
2.2.	System Configuration .....	2
3.	Specifications.....	3
3.1.	General Specifications .....	3
3.2.	Camera Input and Output Signals Specifications .....	4
3.2.1	6pins Circular Connector No.5 pin: TRIGGER_IN Circuit.....	4
3.2.2	6pins Circular Connector No.3 pin: SIGNAL_OUT Circuit .....	4
3.3.	External Connector Pin Assignment.....	5
3.3.1	6pins Circular Connector HR10-10R-12PA(73) (Hirose) or equivalent.....	5
3.3.2	75Ω BNC Connector .....	5
3.3.3	LED Indicator .....	6
3.4.	Spectral Response.....	6
4.	Output Timing.....	7
4.1.	Horizontal Sync. Timing .....	7
4.2.	Vertical Sync. Timing .....	8
5.	Camera Function .....	9
5.1.	Settings .....	9
5.2.	How to Save and Initialize the Settings .....	9
5.3.	Link Speed and Link Count.....	9
5.4.	Pixel Format .....	10
5.5.	Sync. System.....	10
5.5.1	Internal Sync. Mode (Free run mode) .....	10
5.5.2	External Trigger Sync. Mode.....	10
5.6.	Trigger Sync. Mode and Delay Time to Start Exposure .....	12
5.7.	Restrictions on Trigger Pulse Input Timing.....	12
5.8.	Fixed Trigger Shutter Mode (LineSync) H Sync. Trigger.....	13
5.9.	FAST Fixed Trigger Shutter Mode (ClockSync) CLK Sync. Trigger.....	14
5.10.	Pulse Width Trigger Shutter Mode (LineSync) H Sync. Trigger .....	15
5.11.	FAST Pulse Width Trigger Shutter Mode (ClockSync) CLK Sync. Trigger .....	16
5.12.	Exposure Time.....	17
5.13.	Formula to Calculate Manual Shutter Values with H Sync. Mode.....	18
5.14.	Manual Shutter Settings with CLK Sync. Mode (FAST Trigger Mode).....	18
5.15.	Gain.....	18
5.16.	Gamma Correction .....	18
5.17.	Partial Scan (ROI).....	19
5.18.	2×2 Binning Mode.....	21
5.19.	Black Level Adjustment.....	22
5.20.	Image Quality Selection Mode .....	22
5.21.	Defective Pixels Correction.....	22
5.22.	Test Pattern Indication.....	26
5.23.	Cursor Indication .....	26
5.24.	LED Operational Mode.....	26
5.25.	Camera Timing Output .....	26

---

5.26.	User ID Save .....	27
5.27.	Temperature Indication.....	27
6.	Factory Settings .....	28
7.	Dimensions.....	29
7.1.	Camera Dimensions.....	29
7.2.	Optical Axis Accuracy.....	30
8.	Case for Indemnity .....	31
8.1.	Product Warranty .....	31
8.2.	CMOS Pixel Defect.....	31
8.3.	Product Support.....	31

## 1. Handling Precautions

### 1.1. Camera Handling Precautions

- Do not use or store the camera in the extremely dusty or humid places.
- Do not apply excessive force or static electricity that could damage the camera. Handle the camera with care.
- Do not shoot direct images that are extremely bright (e.g., strong light source, sun, etc.). When strong light such as spot light was shot, blooming or smear may occur. Put the lens cap on when camera is not in use.
- Follow the instructions in Chapter 3.3, "External Connector Pin Assignment" for connecting the camera module. Improper connection may cause damages not only to the camera module but also to the connected devices.
- Confirm the mutual ground potential carefully before connecting the camera to monitors or computers. Any AC leaks or coupling noises from the connected devices may cause damages or destroy the camera.
- Do not apply excessive voltage. (Use only the specified voltage.) Unstable or improper power supply voltage may cause damages or malfunction of the camera assembly.
- Our warranty does not apply to damages or defects caused by irregular and/or abnormal use of the product.

### 1.2. Restrictions on Applications

- The camera must not be used for any nuclear equipment or aerospace equipment with which mechanical failure or malfunction could result in serious bodily injury or loss of human life.
- The camera must not be used under conditions or environments other than specified in this manual.

### 1.3. Disclaimers (Exception Clause)

CIS shall be exempted from taking responsibility and held harmless for damages or losses incurred by the following cases.

- In case damages or losses are caused by earthquake, lightning strike, fire, flood, or other acts of God.
- In case damages or losses are caused by deliberate or accidental misuse by the user, or failure to observe the information contained in the instructions in this Product Specification and Operational Manual.
- In case damages or losses are caused by repair or modification conducted by the customer or any unauthorized party.

## 2. Product Outline

VCC-2CXP6M is a CoaXPress interfaced and 2M resolution camera module. 1/1.7 type B/W CMOS sensor is utilized.

### 2.1. Features

- Small footprint: 29mm(H) x 29mm(W) x 55mm(D)
- Global shutter type CMOS sensor
- CoaXPress CXP-3, CXP-6 are supported.
- Exposure and Gain settings
- External trigger mode (Fixed trigger shutter mode / Pulse width trigger shutter mode)
- GenICam complied
- C mount

### 2.2. System Configuration

- Camera
  - ◆ Camera VCC-2CXP6M
- Packaging
  - ◆ Master carton may vary depends on the quantity to be shipped.

## 3. Specifications

## 3.1. General Specifications

<b>Electrical Specifications</b>			
Pick up device	Device type	1/1.7 type Global shutter CMOS	
	Effective pixel number	1632(H) × 1248(V)	
	Unit cell size	4.5μm(H) × 4.5μm(V)	
Video output mode		CoaXPress Ver,1.1.1 complied, CXP-6/CXP-3 x1 complied	
Video output frequency	Pixel clock frequency	74.25MHz	
Video output format		Mono8/Mono10/Mono12	
Frame rate	CXP-3 8bit/10bit/12bit 1 lane	119.5fps/97.3fp/82.7fps	
	CXP-6 8bit/10bit/12bit 1 lane	239fps/194.5fps/165.5fps	
Sync. system		Internal sync. system	
Resolution (The maximum pixel size)		1632(H) × 1248(V)	
Video signals (Gain 0dB)	White clip level	255	At Mono8
	Set up level	0~2	At Mono8
	Dark shading	Under 4dig for both horizontal and vertical.	At Mono8
Sensitivity		F11 400lx (Shutter speed 1/30s, Gain 0dB, Mono8 ) F5.6 400lx (Shutter speed 1/30s, Gain 0dB, Mono10,12 )	
Minimum illumination		F1.4 0.5lx (Shutter speed 1/30s, Gain+18dB, Mono8, level=50%) F1.4 2.0lx (Shutter speed 1/30s, Gain+18dB, Mono10, 12, level=50%)	
Gain variable range		x1~x64 (0dB~+36dB) [Warranty coverage]	
Shutter speed		Manual settings	
Trigger mode		Free run mode (Camera internal trigger) Trigger mode (Host, External terminal) · Fixed trigger shutter mode · Pulse width trigger mode	
Partial scan		Vertical 8 areas can be set.	
Power requirements		PoCXP: 18.5~26V	
Power consumption		3.4W(CXP-3), 3.6W (CXP-6), [At free run]	
<b>Mechanical Specifications</b>			
Dimensions		H:29mm W:29mm D:55mm (Without protruding portion)	
Weight		Approx. 66g	
Lens mount		C mount	

Environmental Specifications			
Safety/Quality standard			
UL: Conform to UL for all materials. CE EMC 2014/30/EU EN61000-6-4:2007+A1:2011 for Emission EN61000-6-2:2005 for Immunity RoHS 2011/65/EU, 2015/863/EU EN50581 (RoHS2)			
Durability	Vibration	Acceleration	: 98m/s <sup>2</sup> (10G)
		Frequency	: 20 ~ 200Hz
		Direction	: X, Y, and Z 3 directions
		Testing time	: 120min for each direction
	Shock	No malfunction shall be occurred with 980m/s <sup>2</sup> (100G) for ±X,±Y, and ±Z, 6 directions without packaging.	
Operation guaranteed temperature		0 ~ +45°C Humidity: 20 ~ 80%RH with no condensation.	
Storage temperature		-25 ~ +60°C Humidity: 20 ~ 80%RH with no condensation.	

3.2. Camera Input and Output Signals Specifications

3.2.1 6pins Circular Connector No.5 pin: TRIGGER\_IN Circuit

- 5.0V, 3.3V CMOS level / TTL level
- Input voltage Low: 0.5Vdc (Max.), High: 2.1Vdc (Min.)

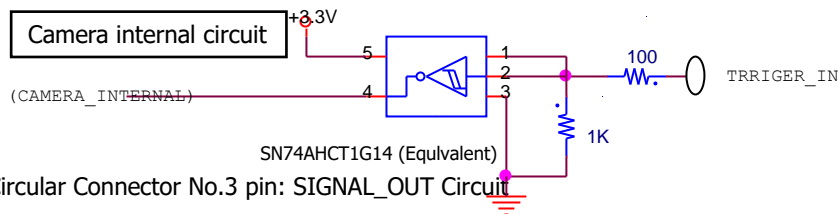

3.2.2 6pins Circular Connector No.3 pin: SIGNAL\_OUT Circuit

- 5.0V CMOS logic level output
- Output voltage Low: 0.35Vdc (Max), High: 4.5Vdc (Min)

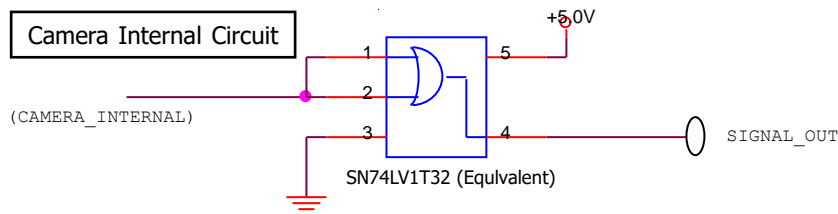

3.3. External Connector Pin Assignment

3.3.1 6pins Circular Connector HR10-10R-12PA(73) (Hirose) or equivalent

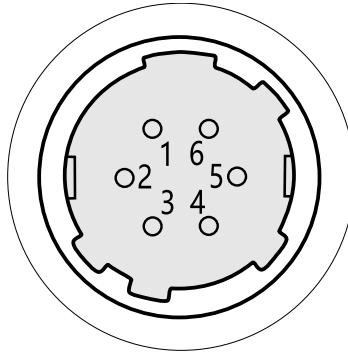

HR10A-7R-6PB (Hirose) or equivalent

Pin No.	Signals	Description
1	NC	
2	NC	
3	SIGNAL_OUT	Exposure/FVAL/LVAL/LinkTrigger
4	NC	
5	TRIGGER_IN	Trigger input
6	GND	Conduction with camera module

※NC=Non-Connection. Do not connect anything to the terminal.

3.3.2 75Ω BNC Connector

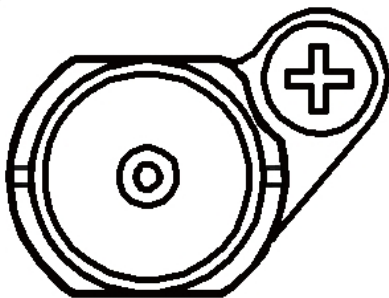

(BCJ-BPLHA Canare)



### 3.3.3 LED Indicator

- When the LED indicator is set to Active, lighting patterns of LED shows the camera status by the way of its lighting.

OFF	No Power supplied
Green lighting	Confirmed connection of the device and the host.
Green fast blinking [12.5Hz] ※	Transmitting video data.
Orange slow blinking [1Hz]	Waiting for the trigger input.
Red fast blinking [12.5Hz]	System error occurred.

- ※ The LED blinks by 12.5Hz when TriggerMode is Off. When TriggerMode is On, LED blinks by the trigger cycle. (It may appear as lighted status, not blinked status at fast trigger.)

### 3.4. Spectral Response

- ※ The lens characteristics, IR cut filter characteristics, and the illuminant characteristics are excluded.

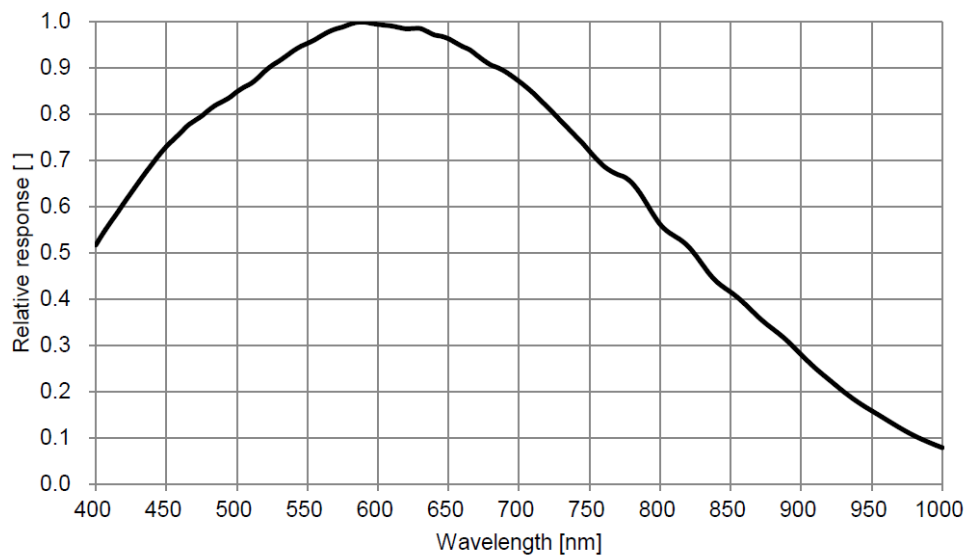

4. Output Timing

4.1. Horizontal Sync. Timing

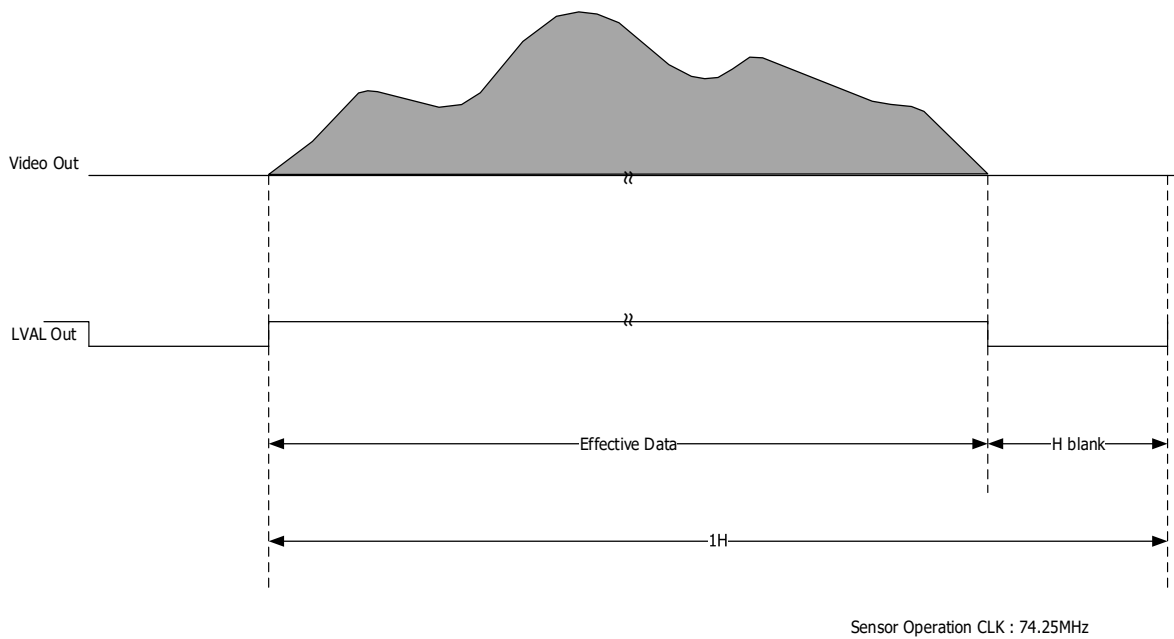

※ The time for 1H shall be changed depends on the link rate and video output format.

※ The blanking pixel number for 1H shall be changed depends on the link rate and video output format.

Effective pixel numbers and blanking pixel numbers

Link rate	Video output format	Effective data	H blank	1H total pixel numbers	Time for 1H[us]
CXP-3	Mono8	204	268	472	6.36
	Mono10	204	376	580	7.81
	Mono12	204	480	684	9.21
CXP-6	Mono8	204	32	236	3.18
	Mono10	204	86	290	3.91
	Mono12	204	138	342	4.61

Sensor Operation clk 74.25 MHz

4.2. Vertical Sync. Timing

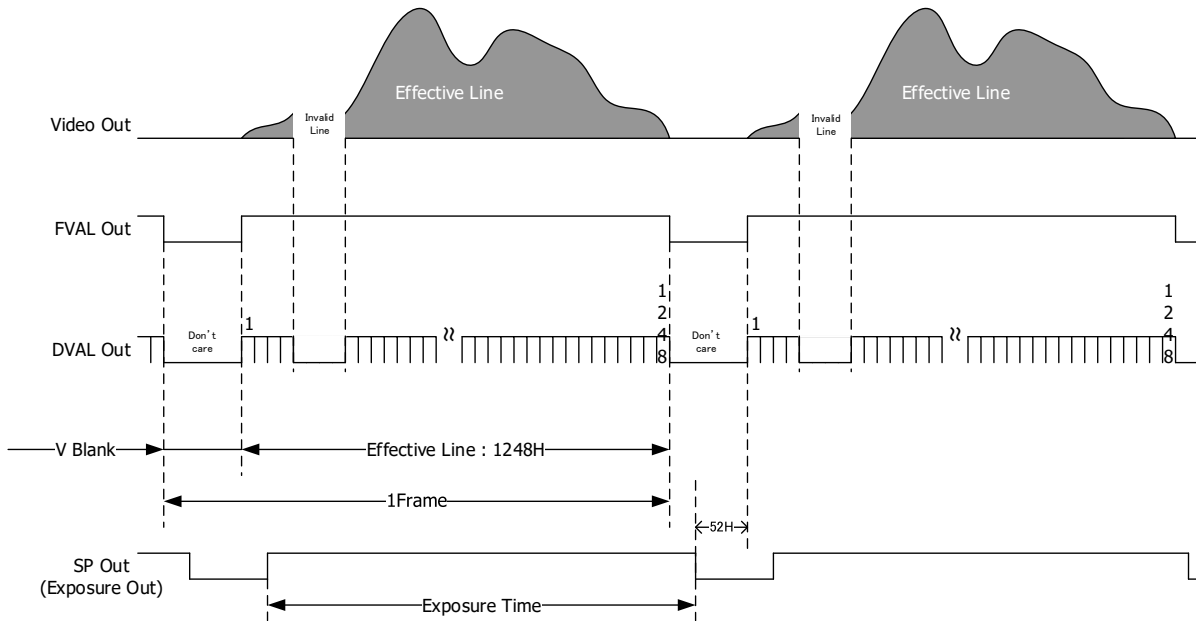

※ The time for 1frame shall be changed depends on the link rate and video output format.

※ The blanking line number for 1frame shall be changed depends on the link rate and video output format.

Effective line numbers and blanking line numbers

Link rate	Video output format	Effective line	V blank	1 frame total line number	Time for 1H [us]	Time for 1 frame [ms]
CXP-3	Mono8	1248	68	1316	6.36	8.37
	Mono10	1248	68	1316	7.81	10.28
	Mono12	1248	64	1312	9.21	12.08
CXP-6	Mono8	1248	68	1316	3.18	4.18
	Mono10	1248	68	1316	3.91	5.15
	Mono12	1248	64	1312	4.61	6.05

Sensor Operation clk 74.25 MHz

5. Camera Function

5.1. Settings

Conform to CoaXPress.

5.2. How to Save and Initialize the Settings

UserSets	
UserSetSelector	Default UserSet0
UserSetLoad	Execute
UserSetSave	Execute

- If you wish to save the setting values, execute "UserSetSave" by selecting UserSet0 (User save area) of UserSetSelector. Doing so, the setting values shall be saved in the camera non-volatile memory.
  - ※ The value cannot be saved to Default (Factory settings).
  - ※ The value of UserSetSelector cannot be saved by UserSetSave. Please set the value before executing UserSetLoad / UserSetSave.
  
- Default (Factory settings) selected by UserSetSelector or UserSet0 (User save area) can be loaded by UserSetLoad.
  - ※ Please do not execute UserSetLoad when grabbing (acquiring image).
  
- Defective pixels correction value and UserID are to be saved when UserSetLoad of Default is executed.
  
- Even executing UserSetLoad, ConnectionConfig, PixelFormat, and Image Quality Mode shall maintain the settings of when executing. Please set the values by command.

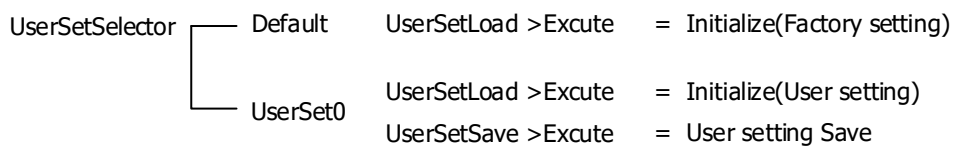

5.3. Link Speed and Link Count

Transfer Control	
ConnectionConfig	CXP3_X1 CXP6_X1

- ◆ CXP-3: Link speed=3.125Gbps, Link count=1
- ◆ CXP-6: Link speed=6.250Gbps, Link count=1

※ Please do not change ConnectionConfig while grabbing (acquiring image).

## 5.4. Pixel Format

ImageFormatControl	
PixelFormat	Mono8 Mono10 Mono12

- ◆ Mono8 : Monochrome 8bit
- ◆ Mono10 : Monochrome 10bit
- ◆ Mono12 : Monochrome 12bit

※ Please do not change PixelFormat while grabbing (acquiring image).

## 5.5. Sync. System

## 5.5.1 Internal Sync. Mode (Free run mode)

- This is a mode to use triggers continuously made in the camera. No external trigger shall be used.
- Set TriggerMode to Off, and set TriggerSelector to AcquisitionStart.
- Frame rate (fps) when ROI is invalid are as follows.

PixelFormat	CXP6_X1	CXP3_X1
Mono8	239.0	119.5
Mono10	194.5	97.2
Mono12	165.4	82.7

## 5.5.2 External Trigger Sync. Mode

- This is a mode to input external trigger signals to capture images by any preferred timings.
- Please set TriggerSelector to AcquisitionStart, and set TriggerSource one out of Software/LinkTrigger0/Line0 and turn On TriggerMode.

Acquisition Control	
TriggerMode	On/Off
TriggerSyncMode	LineSync ClockSync
TriggerSelector	AcquisitionStart FrameStart
TriggerActivation	RisingEdge FallingEdge LevelHigh LevelLow
TriggerSource	Software LinkTrigger0 Line0
TriggerSoftware	Execute

- ◆ TriggerMode : Trigger mode
  - ◆ On : Validate the trigger selected by TriggerSource. (TriggerSelector = FrameStart)
  - ◆ Off : Invalidate the trigger selected by TriggerSource. (TriggerSelector = AcquisitionStart)

※ Please do not change TriggerMode while grabbing (acquiring image).

- ◆ TriggerSyncMode : Trigger sync. mode
  - ◆ LineSync : H sync. trigger mode (Exposure time is controllable per line)  
Fixed/Pulse width trigger shutter mode  
Overlapping operation (Exposure while reading out image) is valid.
  - ◆ ClockSync : CLK sync. trigger mode (Exposure time is controllable per sensor clock)  
FAST fixed/FAST pulse width trigger shutter mode  
Overlapping operation (Exposure while reading out image) is invalid.

※ Please change TriggerSyncMode while there is no trigger input.  
 ※ Please set Free run mode (internal sync. mode) after set itself to LineSync mode.

- ◆ TriggerSelector : Trigger selector  
This is to select how to start capturing the image out of following.
  - ◆ AcquisitionStart : Free run mode [Internal sync. mode]
  - ◆ FrameStart : External trigger mode

※ Please do not change TriggerSelector while grabbing (acquiring image).

- ◆ TriggerActivation : Trigger activation  
This is to select the external signal format and the polarity out of following.
  - ◆ RisingEdge : Fixed trigger shutter mode: Rising edge (Timed)
  - ◆ FallingEdge : Fixed trigger shutter mode: Falling edge (Timed)
  - ◆ LevelHigh : Pulse width trigger shutter mode: High Active (TriggerWidth)
  - ◆ LevelLow : Pulse width trigger shutter mode: Low Active (TriggerWidth)

- ◆ TriggerSource : Trigger source  
This is to select where to input the external trigger.
  - ◆ Software : TriggerSoftware
  - ◆ LinkTrigger0 : External trigger input from CoaXPress Host Device  
Please refer to the product specifications & operational manual of the Host Device (ex. grabber board) to use for how to generate the trigger.
  - ◆ Line0 : Input the external trigger via 6pins circular connector.

※ Software Trigger is valid at Rising Edge.

- ◆ TriggerSoftware : Software trigger  
A trigger is generated in the camera and capture images for 1 frame when this command is executed.  
Please make sure to set TriggerSource to Software.

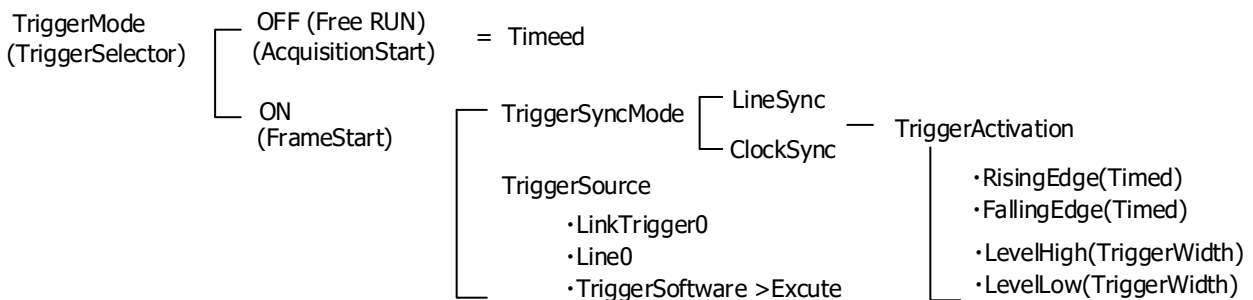

5.6. Trigger Sync. Mode and Delay Time to Start Exposure

- H sync. trigger mode (LineSync): 1H of jitter may occur from inputting trigger to exposure.  
(Overlapping operation is valid.)
- CLK sync. trigger mode (ClockSync): Less delay time from trigger input, and the precise trigger operation is valid.  
(Overlapping operation is invalid.)

Trigger sync. mode and delay time to start exposure

	CXP6_X1	CXP3_X1
Exposure delay to start exposure at H sync. trigger (LineSync)	Approx. 4H~5H	Approx. 4H~5H
Exposure delay to start exposure at CLK sync. trigger (ClockSync)	Approx. 0.13us	Approx. 0.13us

5.7. Restrictions on Trigger Pulse Input Timing

- The next trigger pulse can be input while reading out signals (Readout). However, please do not input a trigger pulse which ends its exposure while reading out the prior signals. In other words, a trigger pulse, while reading out signals for the prior frame and starts reading out signals for the next frame, cannot be input.

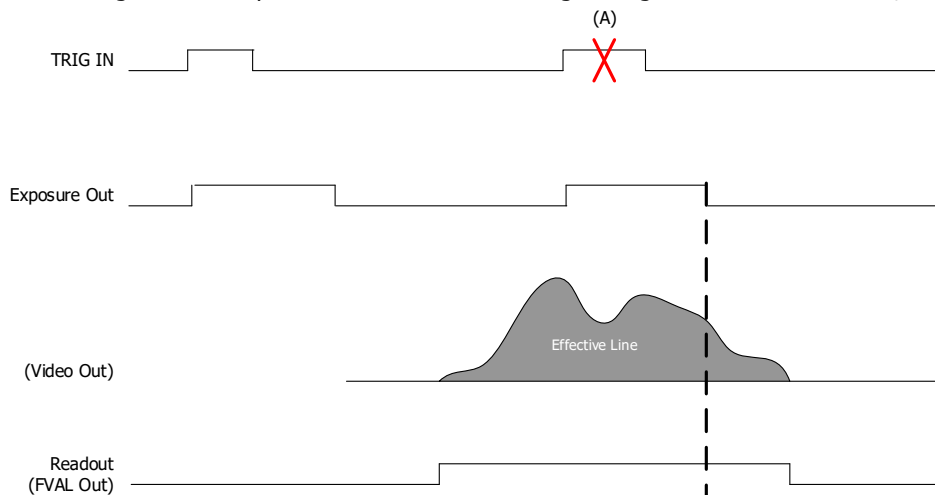

- When a trigger is input with the restricted timing explained the above, "IllegalTriggerFlag" becomes "1".

Acquisition Control	
IllegalTriggerFlag	0 or 1

※ Since overlapping operation is invalid at CLK sync. mode, the trigger at this timing shall be masked and "IllegalTriggerFlag" will not become "1".

Device Control	
ErrorFlagReset	Execute

This is to reset IllegalTriggerFlag to "0".

5.8. Fixed Trigger Shutter Mode (LineSync) H Sync. Trigger

(TriggerMode=On, TriggerSyncMode=LineSync, TriggerActivation= RisingEdge)

- This is the mode to start exposure by the input trigger signals. Exposure time is the set time with "Exposure Time".
- Trigger operation is H sync., V-sync. reset system.
- The delay time (Exposure Time Delay) from detecting the trigger edge in the camera to actually starting exposure is 2H~3H.
- 1H jitter would occur to Exposure Time Delay since the external trigger signal shall synchronize with H inside the camera.

The trigger pulse with the minimum 1H and more shall be input (Please refer to the 1line for each mode in the table below).

Link rate	Video output format	Time for 1H [us]
CXP-3	Mono8	6.36
	Mono10	7.81
	Mono12	9.21
CXP-6	Mono8	3.18
	Mono10	3.91
	Mono12	4.61

- There is an exposure time period for approx. **4.997μs** at the edge right after exposure time.

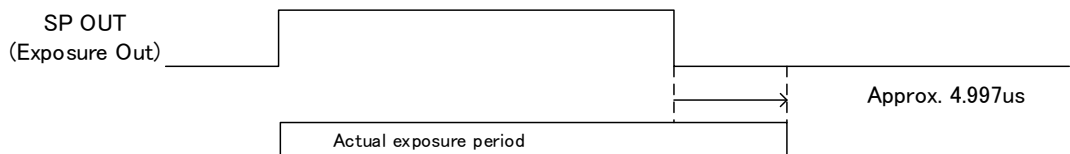

- The next trigger while outputting video for the prior trigger can be accepted. However, do not input a trigger signal to start the next video outputting before completion of outputting the prior images.
- Trigger input while exposure period (Exposure Time) shall be ignored in the camera. ((A) in the drawing below)  
Please note that a trigger shorter than 1 frame cycle shall not be used.



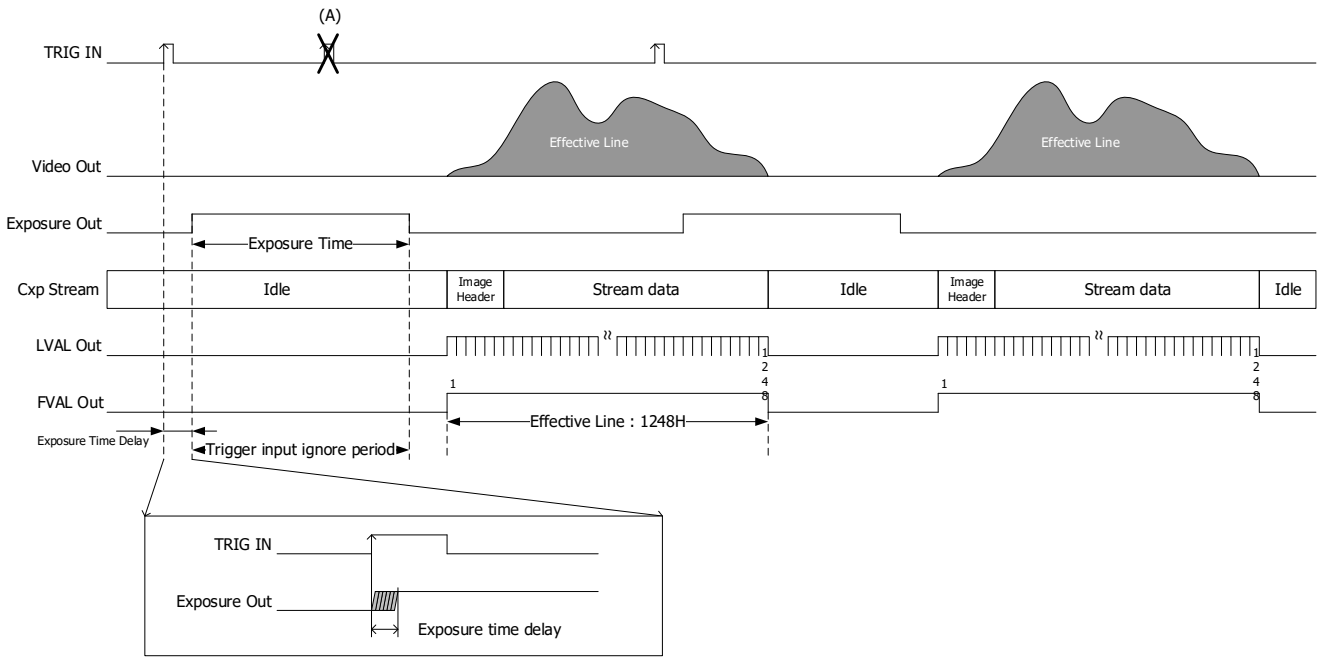

5.9. FAST Fixed Trigger Shutter Mode (ClockSync) CLK Sync. Trigger

(TriggerMode=On, TriggerSyncMode=ClockSync, TriggerActivation= RisingEdge)

- This is the mode to start exposure with external input trigger signals, and execute exposure for set period.
- Trigger operation is CLK sync., V-sync. reset system.

The delay time (Exposure Time Delay) from detecting the trigger edge in the camera to actually starting exposure is approx. **0.13μs**. Please input more than 1μs of pulse to the trigger.

- There is an exposure time period for approx. **4.997μs** at the edge right after exposure time.

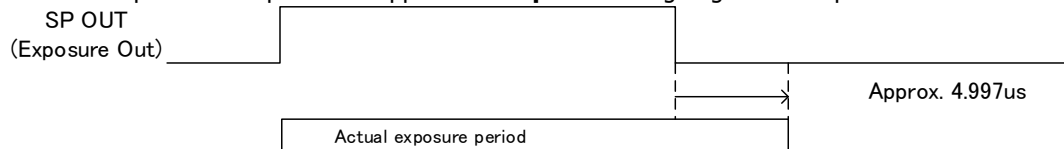

- The next trigger while outputting video for the prior trigger cannot be accepted.

Trigger input while exposure period and reading out period shall be ignored in the camera. (Refer to (A) and (B) in the drawing next page.)

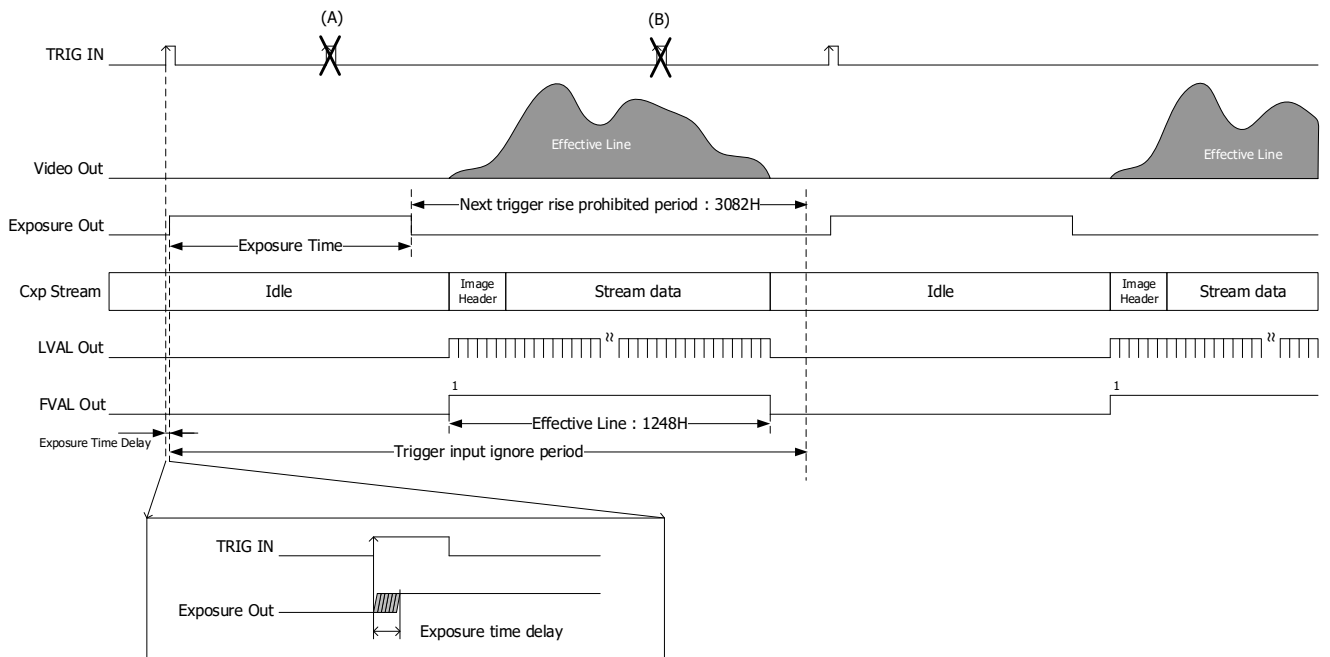

5.10. Pulse Width Trigger Shutter Mode (LineSync) H Sync. Trigger  
 (TriggerMode=On, TriggerSyncMode=LineSync, TriggerActivation=LevelHigh)

- This is the mode to start exposure with external input trigger signals, and set the exposure time with pulse width of the trigger signals.
- Trigger operation is H sync., V-sync. reset system.

The delay time (Exposure Time Delay①) from detecting trigger edge in the camera to actually starting exposure is 4H~5H.

The delay time (Exposure Time Delay②) from detecting trigger edge in the camera to end exposure is

**4H~5H+4.997μs.**

- Since the external trigger signals synchronize with camera internal H signals, approx. 1H jitter occurs to Exposure Time Delay ① and ②. In case of pulse width trigger mode, jitters may occur at both start and end edges of exposure. At this time, exposure time would change so that flicker might be noticeable in the image, especially when high-speed shutter is set. This flicker sometimes can be eliminated when fixed trigger shutter mode is used. However, this problem can be solved by inputting a trigger pulse with synchronizing it to the camera internal H cycle (LVAL).

- Pulse width 1H(Min.) ~ Approx. 2 frames

Functionally, there is no upper limitation, but noises such as dark noises shadings may be noticeable at long time exposure.

- There is an exposure time period for approx. **4.997μs** at the edge right after exposure time.

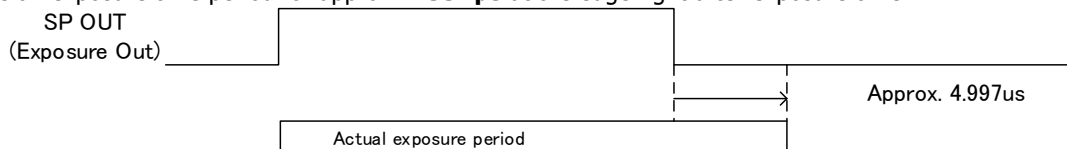

- Trigger input during exposure time shall be ignored in the camera. However, a trigger shorter than 1 frame cycle should not be used.
- Triggers can be accepted while outputting video output images. However, please be noted that a trigger signal to start the next video outputting should not be input before completion of outputting the prior images. (Please refer to (A) in the drawing below).

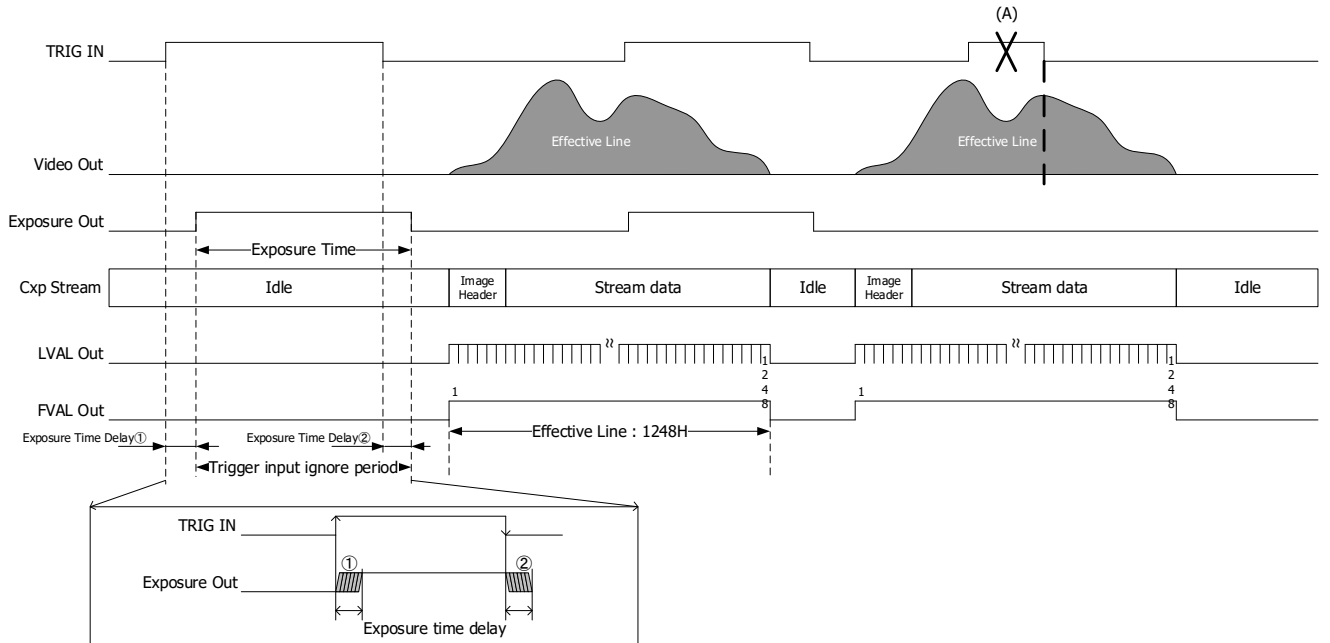

5.11. FAST Pulse Width Trigger Shutter Mode (ClockSync) CLK Sync. Trigger

(TriggerMode=On, TriggerSyncMode=ClockSync, TriggerActivation=LevelHigh)

- This is the mode to start exposure with external input trigger signals, and set the exposure time with pulse width of the trigger signals.
- Trigger operation is CLK sync., and V-sync. restart system.

The delay time (Exposure Time Delay①) from detecting trigger edge in the camera to actually starting exposure is **approx. 0.13μs**. The delay time (Exposure Time Delay②) from detecting trigger edge in the camera to end exposure is **approx. 4.997μs**.

- Pulse width **0.74μs** (Min.) ~ Approx. 2 frames

Functionally, there is no upper limitation, but noises such as dark noises shadings may be noticeable at long time exposure.

- There is an exposure time period for **approx. 4.997μs** at the edge right after exposure output.

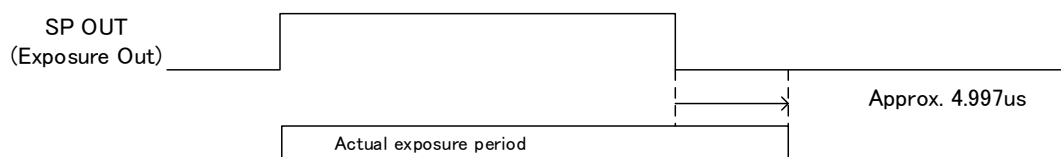

☐ Trigger input during readout time shall be ignored in the camera. (Please refer to (A) in the drawing below).

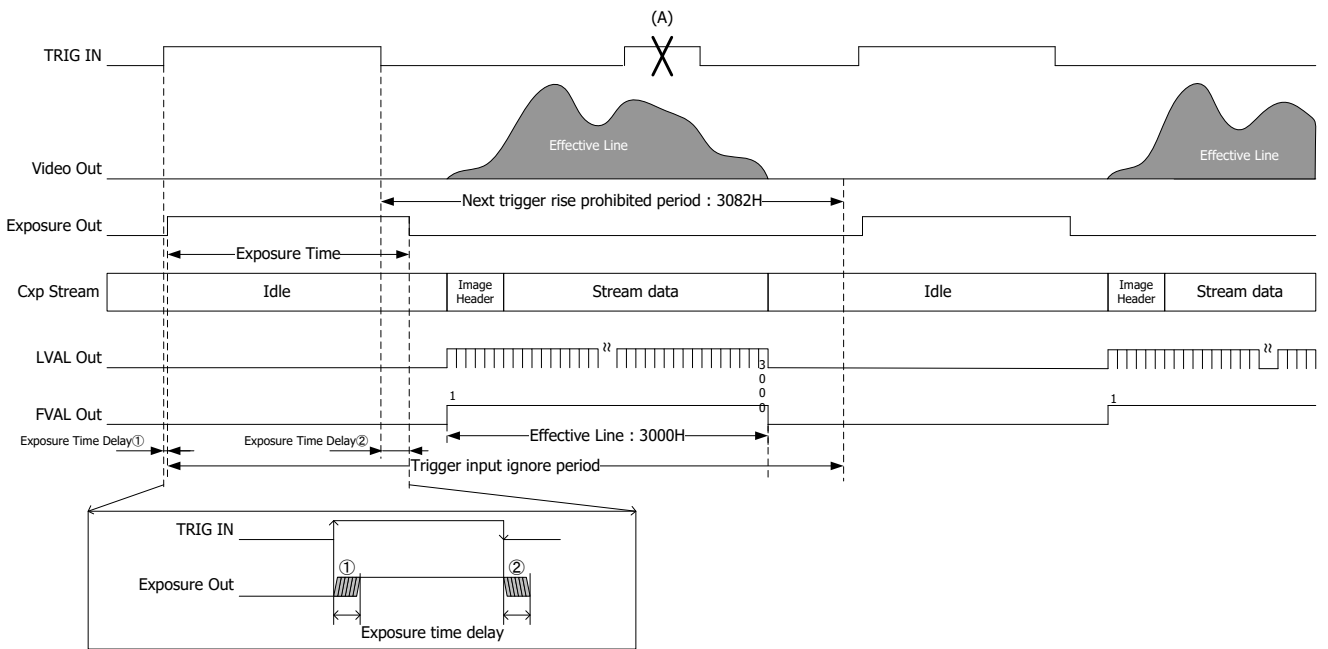

5.12. Exposure Time

Acquisition Control	
ExposureMode	Timed TriggerWidth
ExposureTime (us)	5us~Max. exposure time: LineSync 10us~200ms: ClockSync
ExposureTimeMax	(ReadOnly)

ExposureMode (Read only): This is to check if the current mode is at Timed or TriggerWidth (PWC).

ExposureTime: Exposure time (Valid when ExposureMode is at Timed)

- Please set per 1H at H sync trigger. It shall return the value (us) rounded by 1H per Min. 1H mode.
- It can be set per approx. 1us at CLK sync. trigger.

ExposureTimeMax: Max. exposure time

- Please set the smaller value than ExposureTimeMax at internal sync. mode.
- It shall depends on partial scan (ROI) settings, PixelFormat, and link rate.

- ※ The maximum of H sync. trigger mode (LineSync) shall be clipped with effective line count (Including at partial).
- ※ CLK sync. trigger mode (ClockSync) can be set from CLK 10us~200ms. It shall not be clipped with effective line count.

## 5.13. Formula to Calculate Manual Shutter Values with H Sync. Mode

The values shall be corrected correspond to the formula below.

Formula: Exposure time = Time for 1 line (Please refer to the table below) × Exposure line count + **4.997μs**

Link rate	Video output format	Time for 1H [us]
CXP-3	Mono8	6.36
	Mono10	7.81
	Mono12	9.21
CXP-6	Mono8	3.18
	Mono10	3.91
	Mono12	4.61

- ※ The Min. setting value shall be clipped with 1, and the Max. value shall be clipped with 1248 or with the total line count at partial mode.

## 5.14. Manual Shutter Settings with CLK Sync. Mode (FAST Trigger Mode)

Exposure time = Setting value + **4.997μs**

- Min. setting value: **10μs** (Approximate value)
- Max. setting value: **200ms** (Approximate value)
  - ※ Unlike H sync. mode, clipping shall not be executed by total line count, etc.
  - ※ Bright point may be noticeable at long time exposure.
- Setting unit: 1μs (Approximate value) ※ Slight differences may occur since it is generated by 74.25MHz clock.

## 5.15. Gain

AnalogControl	
Gain	Manual

Functionally, up to 256 times of the value can be set. However, image degradation cannot be avoided at high gain. We recommend you to evaluate it first.

## 5.16. Gamma Correction

- This is to execute gamma correction.

AnalogControl	
Gamma	Settings for the coefficient of 0.10~1.80

Gamma: This is to set the gamma correction value per 0.01step.

[Note] Gamma table shall be updated at image output timing. It shall be applied at image output after the completion of rewriting the gamma table (Approx. 20ms: Command ACK is the rough standard.) at continuous operation mode. In case the gamma coefficient is changed while waiting trigger to be input, the gamma updated image shall be output with the trigger after the completion of rewriting the table.

## 5.17. Partial Scan (ROI)

- This is to increase its frame rate by cutting out and reducing the read out area.
- This function cannot be used with 2×2 Binning mode.
- It shall be Idle output in case the RegionMode of Region 1~8 is all off.
- Max. 8 partial areas can be set.

<b>ImageFormatControl</b>	
RegionSelector	EffectiveRegion, Region1~8
RegionMode	On/Off
RegionDestination	Stream0
Width	1632
Height	8~1248 (Multiples of 8)
OffsetX	0
OffsetY	0~1240 (Multiples of 8)

- RegionSelector: This is to select the region to be set.  
8 partial areas can be set with Region1~8.  
Width and Height of the effective partial area can be checked by selecting EffectiveRegion.  
  
※Please do select EffectiveRegion to start acquiring images.  
※Please do select EffectiveRegion when selecting 2×2 binning mode.
- RegionMode: This is to set valid/invalid of selected Region.  
Valid can be set to each Region with Region1~8. Effective Region can be checked by EffectiveRegion.  
※This function cannot be turned ON in case Width, Height, OffsetX, and OffsetY are not set to effective settings.
- RegionDestination: This is to select the Stream to be output. This model VCC-2CXP6M is fixed to Stream0.
- Width: This is to set the width of Region. This model VCC-2CXP6M is fixed to 1632.
- Height: This is to set the height of Region.  
※Please make sure that the Height setting does not overlap with other Regions correspond to OffsetY setting.
- OffsetX: This is to set the Offset settings for X direction of the Region. This model VCC-2CXP6M is fixed to 0.
- OffsetY: This is to set the Offset settings for Y direction of the Region.  
  
※Please make sure that the OffsetY setting does not overlap with other Region correspond to Height setting.

Example: 3 partial areas to be set.

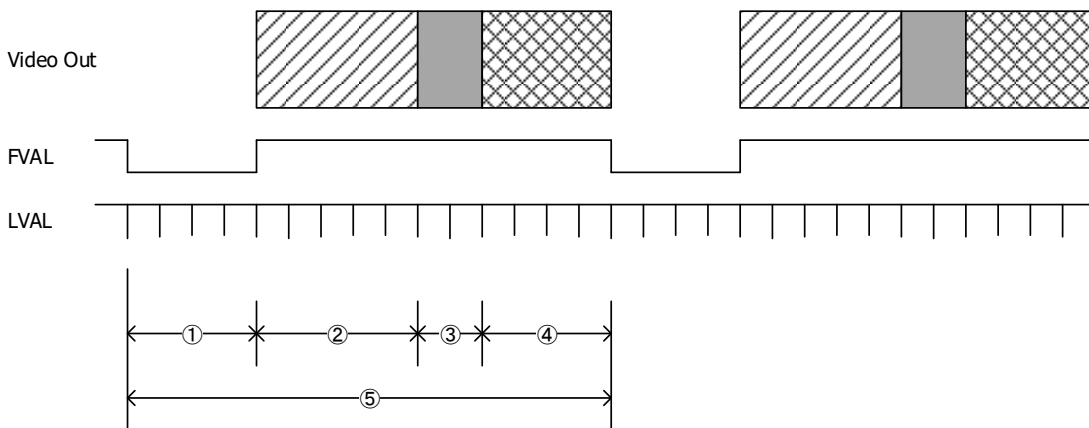
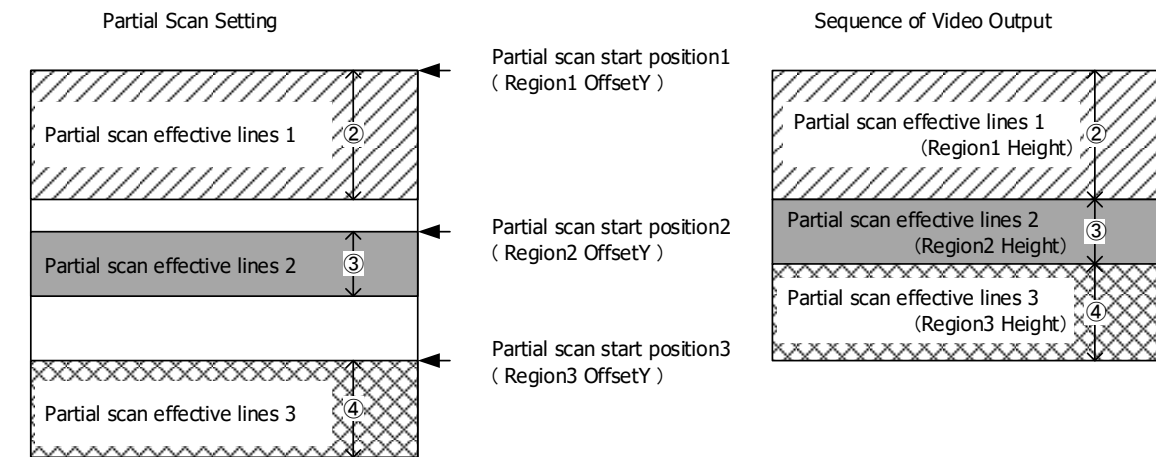

- ① : V blanking line
- ② : Partial area 1
- ③ : Partial area 2
- ④ : Partial area 3
- ⑤ : Frame total line count

When setting several partial scan areas, please set the start position and effective lines trying not to overlap the areas.

$8\text{Total line count per frame} = \text{V blanking lines} + \text{Partial effective line 1} + \text{Partial effective lines 2} + \dots + \text{Partial effective lines 8}$

Please note that sum total of partial effective line numbers from 1~8 (except V blanking lines) has to be less than 1248.

V blanking lines at partial mode is **64 or 68H**.

- Frame rate = 1 / (Total line count per frame × Time for 1 line)

Time for 1 line

Link rate	Video output format	Time for 1H [us]
CXP-3	Mono8	6.36
	Mono10	7.81
	Mono12	9.21
CXP-6	Mono8	3.18
	Mono10	3.91
	Mono12	4.61

- The line numbers at partial scan setting can be set from 8 lines. Only multiple numbers of 8 can be set. The effective line numbers of the manual shutter setting value at partial scan setting become the maximum (except at ClkSync trigger).
- When you switch between Full Frame Scan Mode and Partial Scan Mode or when you change Partial scan settings, the first one frame right after the changes shall be invalid.  
**\*Especially at fixed trigger shutter mode and pulse width trigger shutter mode, input a dummy Trigger first, and use the next trigger as an actual video signal.**

5.18. 2×2 Binning Mode

ImageFormatControl	
BinningHorizontalMode	Sum
BinningHorizontal	1~2
BinningVerticalMode	Sum
BinningVertical	1~2

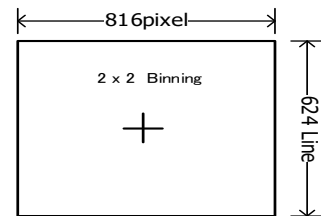

- Since the settings for Horizontal and Vertical are linked, 2x2 binning mode is executed when either is set to 2.
  - ※ This cannot be set unless DefectPixelCorrection is OFF. Defective pixels correction shall be invalid at this mode.
  - ※ BinningHorizontal and BinningVertical cannot be changed unless RegionSelector is at EffectiveRegion.
- 4 pixels of horizontal and vertical shall be mixed and output as 1 pixel. The sensitivity shall be 4 times higher. This is fixed to simple addition (Sum).
- Frame rate can be increased with the field angle at full resolution since the vertical line shall be 1/2.
- This mode cannot be used with partial scan (ROI) function.

Frame rate at Bining mode [fps]

2x2Bining mode (Number of pixels)	PixelFormat	Link rate (fps)	
		CXP6_X1	CXP3_X1
(816x624)	Mono8	796.1	398.0
	Mono10	662.3	331.1
	Mono12	521.8	260.9



## 5.19. Black Level Adjustment

- This is the function to adjust black level of image sensor.

AnalogControl	
BlackOffset	-64~63

[Note] This function is not the function to set the absolute value of black level.

This function can change the black level settings of the image sensor relatively.

This value is 12bit converted. In case of 10bit, the value shall be equivalent to  $\pm 16$ , and in case of 8bit, the value shall be equivalent to  $\pm 4$ .

Settings can be changed while capturing images. However, image may be distorted.

## 5.20. Image Quality Selection Mode

- This is to select image quality of output image.

AnalogControl	
Image Quality Mode	StandardMode LowNoiseMode LowFrameRateMode

- ♦ Image Quality Mode: Image quality selection mode
- ♦ StandardMode: Standard mode
- ♦ LowNoiseMode: SN shall be improved compared to StandardMode, however the sensitivity shall be decreased.
- ♦ LowFrameRateMode: SN shall be improved more compared to LowNoiseMode, however the frame rate and the sensitivity shall be decreased. Valid only at Mono8.

## 5.21. Defective Pixels Correction

- This is the function to detect and correct the defective pixels in the data output from the sensor.
- Data are categorized into two types and controlled.
  - Data at Ex-Factory
    - The detected data of white pixel defects and black pixel defects at Ex-Factory are saved.
    - Basically, these data cannot be erased.
  - Data registered by users
    - Data increased after shipment or the one registered by users.
    - These data can be entirely erased anytime by DefectPixelDefault.
- The number of data registerable by users is 128 points. (Note: Up to 32 points per CH.)

[CH (Channel)]

Images are processed by 4CH interleave in the camera.

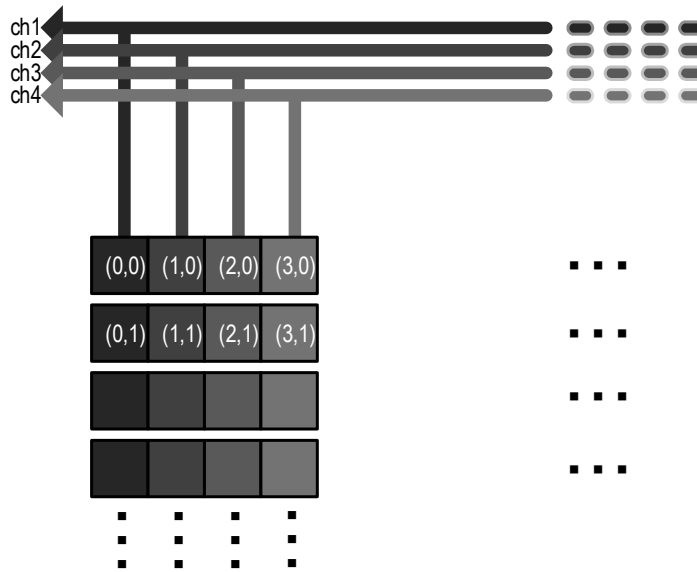

X pixel value shall be calculated by referring pixel values of X1, X2, X3, and X4 as the left drawing. When X1, X2, X3, and X4 are already registered as defected pixels, X can be added to be registered, but it cannot be corrected.

Defective pixels correction control

This is to select ON/OFF of defective pixels correction processing.

Data at Ex-factory and data registered by users are both controlled at the same time.

AnalogControl	
DefectPixelCorrection	On/Off
DefectPixelAdd	(Execute)
DefectPixelAddOffsetY	0~1247
DefectPixelAddOffsetX	0~1631
DefectPixelDelete	(Execute)

Defective pixels registered by users

This is to add the specified X and Y coordinate.

Any preferred pixels can be registered and deleted as defective pixels by specifying coordinate.

- DefectPixelCorrection: This is to select valid/invalid of defective pixels correction.
- DefectPixelAddOffsetY: This is to specify Y coordinate
- DefectPixelAddOffsetX: This is to specify X coordinate
- Please execute DefectPixelAdd to register the specified coordinate as a defective pixels correction point.
- Please execute DefectPixelDelete to delete the specified coordinate as a defective pixels correction point.

- ◇ Defective pixels correction cannot not be valid while binning.
- ◇ In case the coordinate same as the defective data at ex-factory is specified, it shall be ignored.
- ◇ Only the added pixels by "Defective pixels detection registered by user" or "Defective pixels added by user" can be deleted. Data at ex-factory cannot be deleted by this command.

Defective pixels detection registered by user

This is to detect and register the correction data of white defect caused by the image sensor.

<b>AnalogControl</b>	
DefectDetectionThesholdValue	0~4095
DefectDetection	(Execute)
DefectDetectionStatus	(ReadOnly)
DefectPixelDefault	(Execute)
DefectCorrectMode	Reacquire/Add

- ♦ DefectDetectionThesholdValue: This is to set the threshold value (0~4095: 12bit equivalent) of defective pixels detection registered by user. The data with luminance level more than the specified level here shall be registered.
  - ※ 16times more value of the image signal level shall be specified as the threshold value with 8bit images.
- ♦ DefectDetection: This is to detect the defective pixels registered by user.
 

This is the function to register the pixels automatically if a pixel exceeds the level specified at DefectDetectionThresholdValue. Please be noted that no lights should be in the sensor surface to use this function.

The defective pixels correction registered by user shall be reflected right after the execution.

In case UserSetSave is executed after defective pixels detection registered by user, the data will be saved in non-volatile memory.

  - ♦ DefectDetectionStatus: This is to indicate the result of the defective pixels correction detection registered by user.

0	None defective pixels correction data registered by user
Value (128 or less)	When operating correctly (Detected number of defective pixels registered by user)
0x000e0001(917505)	Defective pixels correction data exceeds the maximum number (128 points) registerable.
0x000e0002(917506)	Defective pixels correction data exceeds the maximum number (32 points) registerable in one CH.

If the 129 points or more is indicated, please check the threshold value (DefectDetectionThesholdValue) of defective pixels detection registered by user is correct.

※ Please note that the error indication may appear in decimal depends on frame grabber board to use.

- ♦ DefectPixelDefault: This is to delete entire defective pixels correction data registered by user.
- ♦ DefectCorrectMode: This is to set the detection mode of defective pixels.
  - In case Reacquire is selected, other than defective pixel added by one point addition shall be deleted, and reacquire the defective point again.
  - In case Add is selected, the defect point is additionally acquired for the current defect point.

[Note]

- ♦ Correction data shall be acquired only when the camera is in operation. When camera is not outputting anything, white defect detection cannot be performed.
- ♦ When detecting defects, partial scan, binning mode, and shading shall be OFF. (Size shall be set to 1632 x 1248)
- ♦ When changing the threshold value of DefectDetectionThresholdValue and acquiring the defective pixels correction data, please execute DefectPixelDefault and delete the defective pixels correction data registered by user to reacquire it.

- ♦ The registerable number of pixel defects and the correctable number of pixel defects may not be always the same because of the following reasons.
  - (1) With white defects detection, if one of the strip reed reached the maximum number, correction could not be performed. In such case, the data up to that point are registered, error is output, and operation ends.
  - (2) If no effective pixel exists up next, down next, right next, or left next to the pixel to be corrected, this pixel can be registered but cannot be corrected.

Defective pixels indication

This is to indicate the coordinate of defect registered by user.

<b>AnalogControl</b>	
RegisteredDefectSelector	UserState/InitialState
DefectPixelNumber	1~128/1~384
DefectPixelOffsetY	(ReadOnly)
DefectPixelOffsetX	(ReadOnly)
DefectPixelType	(ReadOnly)

- ♦ RegisteredDefectSelector: This is to select the type of defect.
- ♦ DefectPixelNumber: This is to set the number to the registered defect.  
The table number of the defect data at ex-factory and the defect registered by user shall be specified.
- ♦ DefectPixelOffsetY: This is to indicate the Y coordinate of the defect specified at DefectPixelNumber.  
65535 shall be indicated for the number of the table which does not have defect data.
- ♦ DefectPixelOffsetX: This is to indicate the X coordinate of the defect specified at DefectPixelNumber.  
65535 shall be indicated for the number of the table which does not have defect data.
- ♦ DefectPixelType: This is to indicate the defect type specified at DefectPixelNumber.
  - 1: White defect at ex-factory
  - 2: Black defect at ex-factory
  - 6: Defect registered by user
  - 7: Defect additionally registered by user
  - 65535: The table which does not have defect data

<b>AnalogControl</b>	
ChannelNumber	1~4
DefectPixelChannelCount	(ReadOnly)

- ♦ ChannelNumber: This is to specify the channel number of defect processing.
- ♦ DefectPixelChannelCount: This is to indicate the number of defects of channel number specified at ChannelNumber. The specified number of the defect of the channel number is the sum total of the defects at ex-factory and the number of defects registered by user.

5.22. Test Pattern Indication

- Test pattern can be output from the camera. It is useful to check if your system is operating properly.

ImageFormatControl	
TestPattern	Off GrayHorizontalRamp

※ This function cannot be set when cursor indication is ON.

5.23. Cursor Indication

- This is to indicate the cursor on the screen.

ImageFormatControl	
CursorPattern	Off/On
CursorOffsetX	X coordinate
CursorOffsetY	Y coordinate
CursorColor	White/Black

※ This function cannot be set when test pattern indication is ON.

- CursorPattern: Specify if the cursor shall be indicated or not.
- CursorOffsetX: This is to specify the X coordinate of vertical cursor.
- CursorOffsetY: This is to specify the Y coordinate of horizontal cursor.
- CursorColor: This is to specify the color of the cursor. (White/Black)

5.24. LED Operational Mode

- When it is ON, lighting patterns of LED shows the camera status by the way of its lighting.

DeviceControl	
DeviceIndicatorMode	Active ErrorStatus Inactive

- Active : This is to indicate the communication status of CoaXPress.
- ErrorStatus : Lights OFF at normal status. Lights only when there was a system error.
- Inactive : ALL LED OFF.

5.25. Camera Timing Output

- The signals below can be output from 3pin of 6pins circular connector by LineSource settings.

Digital IO Control	
LineSelector	Line0
LineMode	Output
LineSource	OFF ExposureActive FrameActive LineActive TriggerPacketActive

- LineSource
  - ExposureActive : This is to indicate exposure period of image sensor by Hi Active.
  - FrameActive : This is to indicate effective period of frame by Hi Active.
  - LineActive : This is to indicate effective period of line by Hi Active.
  - TriggerPacketActive : This is to output uplink trigger packet signal from frame grabber by decoding.

## 5.26. User ID Save

- This is the function to set data with up to 16 letters. (Including NUL character ( )) By executing "UserSetSave", data shall be saved in the non-volatile memory. This item shall maintain the set value even execute "UserSetLoad" at "Default".

DeviceControl	
DeviceUserID	Manual

## 5.27. Temperature Indication

- This is to indicate the temperature of the image sensor. (Indicate by  C)

DeviceControl	
DeviceTemperature	ReadOnly

[Note] This value shall not be calibrated. Please regard this value as a reference value

## 6. Factory Settings

Function	Data	Description
TriggerSelector	AcquisitionStart	Equivalent to TriggerMode=Off
TriggerMode	Off	Link to TriggerSelector
TriggerSyncMode	LineSync	Horizontal sync. mode
TriggerSource	LinkTrigger0	CXP UPLink trigger
TriggerActivation	RisingEdge	Rising edge
ExposureTime	7938.0	7.938ms
Gain	1.00	x1.00
Gamma	1.00	Gamma coefficient=1.00
DefectPixelCorrection	On	Defective pixels correction On
DefectPixelAddOffsetX	0	This is to specify X coordinate to correct defective pixels.
DefectPixelAddOffsetY	0	This is to specify Y coordinate to correct defective pixels.
DefectDetectionThesholdValue	50	Defective pixels detection threshold value
BlackOffset	0	Black level initial value
PixelFormat	Mono8	B/W model
ConnectionConfig	CXP3_X1	CxpLinkConfiguration
TestMode	NomalOperation	Link test Off
RegionSelector	EffectiveRegion	This is to specify the number of Partial area (ROI) (Region1)
RegionMode	On	Partial area (ROI) On/Off
Height	1248	Partial area (ROI) Specify height.
OffsetY	0	Partial area (ROI) Specify the start position.
TestPattern	Off	Cursor indication and Test pattern cannot be ON at the same time.
CursorPattern	Off	Test pattern and Cursor pattern cannot be ON at the same time.
CursorOffsetX	816	This is to specify the position of cursor X
CursorOffsetY	623	This is to specify the position of cursor Y
CursorColor	White	Cursor color White/Black
BiningHorizontal	1	2x2 binning mode
BiningVertical	1	2x2 binning mode
DeviceIndicatorMode	Active	Indicate LED indicator
LineSource	Off	Circular 6P-3pin output settings
DeviceUserID		User letter string setting (16 letters)

7. Dimensions

7.1. Camera Dimensions

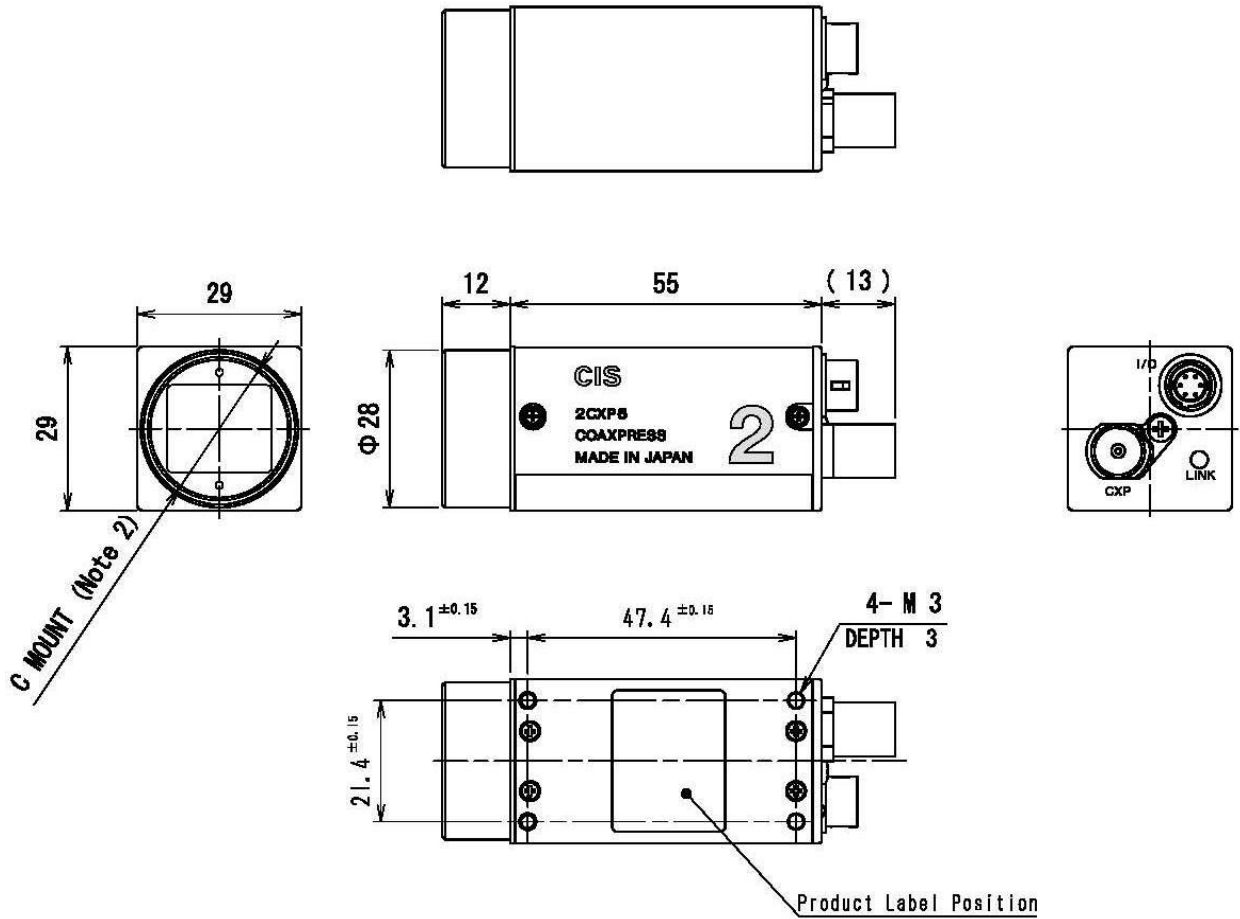

Note2) C mount screws comply with ANSI/ASME B1.1.1-32UN(2B).

Note1) Screw length from the lens mount surface shall be less than 6 mm. And protruding portion of the C mount lens shall be less than 10 mm.

935-0131-00-00  
(Unit : mm)



7.2. Optical Axis Accuracy

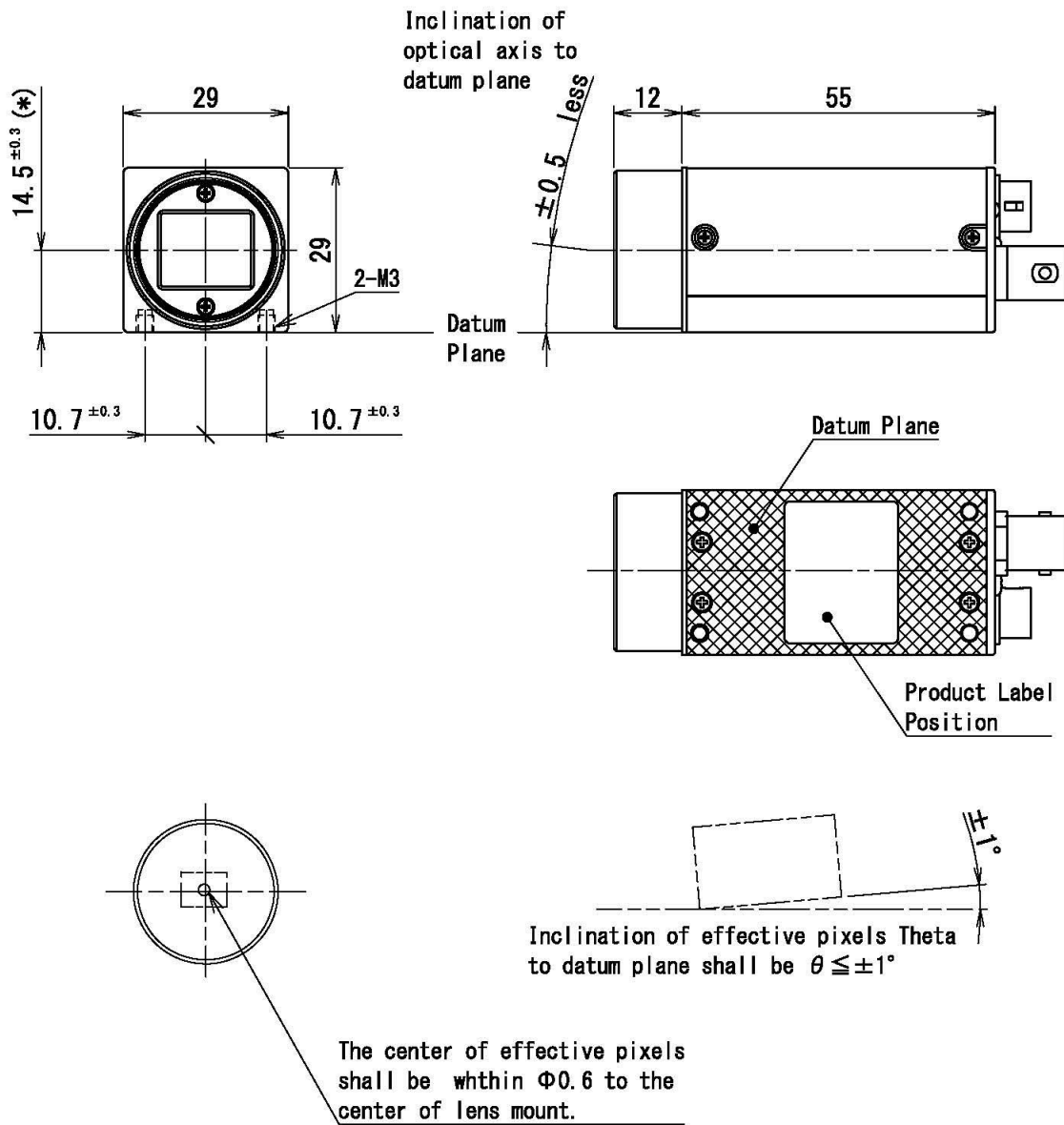

(\*)Dimension from datum plane to the center of lens mount.

937-0012-00  
(Unit:mm)

## 8. Case for Indemnity

### 8.1. Product Warranty

The term of warranty of this product is within 3 years from the date of shipping out from our factory.

If you use the product properly and discover a defect during the warranty period, and if that was caused by designing or manufacturing, CIS Corporation, at its option, repairs or replaces it at no charge to you. Products out of warranty period will be subject to charge. CIS repairs the products as long as it is repairable.

CIS shall be exempted from taking responsibility and held harmless for damages or losses incurred by the following cases.

- In case damages or losses are caused by earthquake, lightning strike, fire, flood, or other acts of God.
- In case damages or losses are caused by deliberate or accidental misuse by the user, or failure to observe the information contained in the instructions in this Product Specification and Operational Manual.
- In case damages or losses are caused by repair or modification conducted by the customer or any unauthorized party.

### 8.2. CMOS Pixel Defect

CIS compensates the noticeable CMOS pixel defects found at the shipping inspection prior to our shipment. On very rare occasions, however, CMOS pixel defects might be noted with time of usage of the products. Cause of the CMOS pixel defect is the characteristic phenomenon of CMOS sensor itself and CIS is exempted from taking any responsibilities for them. Should you have any questions on CMOS pixel defects compensation please contact us.

### 8.3. Product Support

Should you have any problems in function of the product you purchased, and if you need our further analysis and/or repair, please contact the dealer you purchased it from.