



- Sony ICX415 CCD sensor
- Power over Ethernet optional
- Angled-head and board level variants
- Video-iris lens control

简化多相机应用设置

搭载千兆网接口的模块化机器视觉相机

Manta G-046 搭载 Sony ICX415 传感器，在 67.5MP 分辨率下速度可达 0.5 帧/秒。

Manta 是 Allied Vision 用途最广泛的千兆网口相机系列。该系列相机可提供最丰富的图像传感器选项，并且凭借先进的功能组合简化了多相机应用设置。模块化硬件概念更是让 Manta 相机可提供近乎无限的配置选择，以灵活满足各种应用的需求。

Easy software integration with Allied Vision's [Vimba Suite](#) and compatibility to the most popular [third party image-processing libraries](#).

See the [Modular Concept](#) for lens mount, housing variants, optical filters, case design, and other modular options. See the [Customization and OEM Solutions](#) webpage for additional options.

性能参数

Manta G-046	
接口	IEEE 802.3 1000BASE-T, IEEE 802.3af (PoE) optional
分辨率	780 (H) × 580 (V)
传感器	Sony ICX415
传感器类型	CCD Progressive
快门种类	Global shutter
传感器尺寸	Type 1/2
像元尺寸	8.3 μm × 8.3 μm

Manta G-046	
Lens mounts (available)	C-Mount, CS-Mount, S-Mount
最大满帧帧率	67.5 fps
ADC	12 Bit
缓存 (RAM)	32 MByte
非易失性内存 (Flash)	192 KByte (for selected models only)
成像性能	
<p>成像性能数据是基于欧洲机器视觉协会 (EMVA) 1288 发布的 3.1 版图像传感器和像机特征描述标准中的评估方法。测量值是在没有光学滤波片的全分辨率下，测量单色模型的典型值。请联系销售或工程师了解更多信息。</p>	
在波长为 529nm 下，量子转换效率	37 %
暗噪声	21.1 e ⁻
饱和电子数	15700 e ⁻
动态范围	57.2 dB
绝对灵敏度阈值	21.6 e ⁻
输出	
Bit 位数	8-12 Bit
黑白像素格式	Mono8, Mono12, Mono12Packed
YUV 彩色像素格式	YUV411Packed, YUV422Packed, YUV444Packed
RGB 彩色像素格式	RGB8Packed, BGR8Packed, RGBA8Packed, BGRA8Packed
原始像素格式	BayerRG8, BayerRG12Packed, BayerRG12
通用输入输出 (GPIOs)	
光耦 I/Os	2 inputs, 2 outputs
RS232	1
工作条件/尺寸	
工作温度	+5 °C to +45 °C ambient (without condensation)
电源要求 (DC)	8 to 30 VDC AUX or IEEE 802.3af PoE
功耗	External power: 3.6 W at 12 VDC Power over Ethernet: 4.2 W
重量	200 g; 210 g (PoE models)
尺寸 (L × W × H in mm)	86.4 × 44 × 29 (including connectors)

Manta G-046

符合规范

CE: 2014/30/EU (EMC), 2011/65/EU, including amendment 2015/863/EU (RoHS); FCC Class B; CAN ICES-3 (B)

量子转换效率

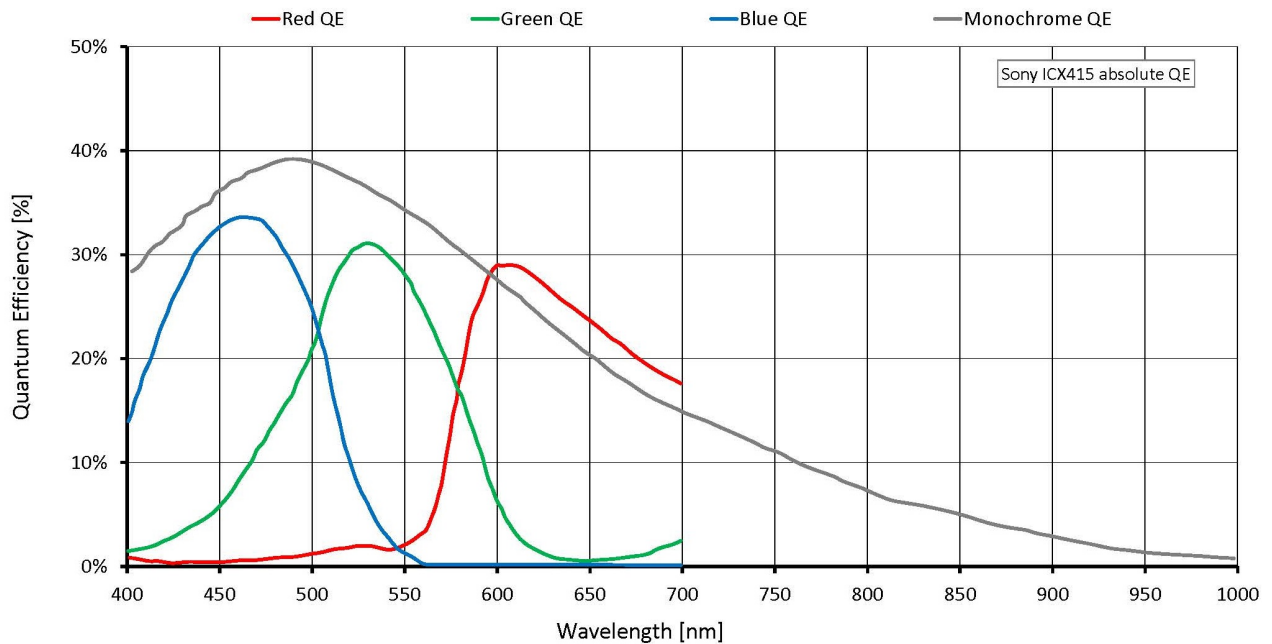

特性

Image optimization features:

- Auto gain (manual gain control: 0 to 31 dB, 1 dB increments)
- Auto exposure (26 μ s to 60 s, 1 μ s increments)
- Auto white balance (G-046C only)
- Binning
- Black level (offset)
- Color correction, hue, saturation (G-046C only)
- Decimation
- Gamma correction



- Three look-up tables (LUTs)
- Region of interest (ROI), separate ROI for auto features
- ReverseX (G-046B only)

Camera control features:

- Auto-iris (video type)
- Event channel
- Image chunk data
- Storable user sets
- StreamBytesPerSecond (bandwidth control)
- Stream hold
- Sync out modes: Trigger ready, input, exposing, readout, imaging, strobe, GPO
- Non-volatile memory 192 KByte (for selected models only)

外形尺寸

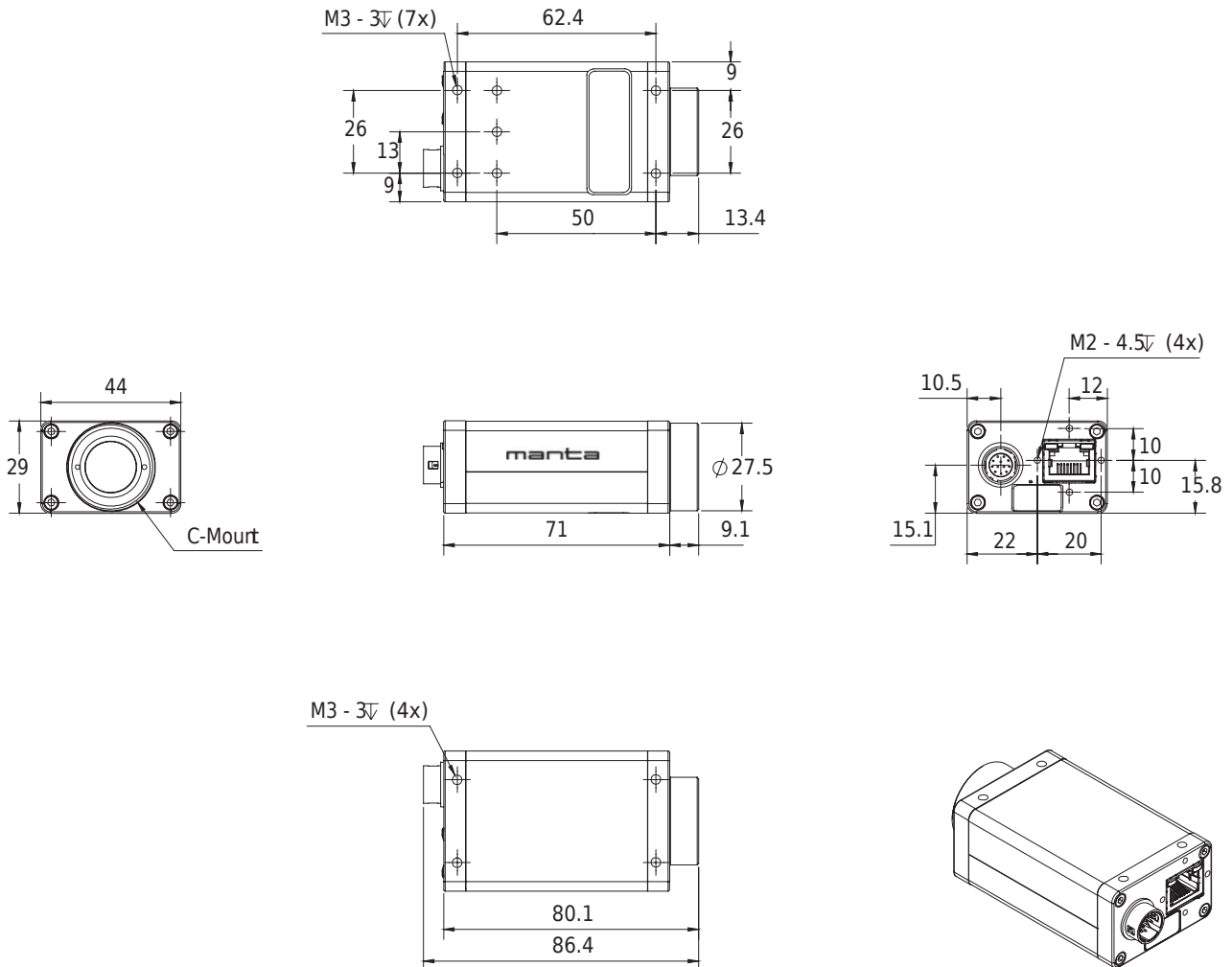

应用场景

Manta G-046 is suitable for a wide range of applications including:

- Applications which require high sensitivity (low light)
- Semiconductor inspection
- Pharmaceutical inspection
- Logistics
- Intelligent traffic solutions (ITS)/Traffic monitoring