

Linea™ HS Color

16k Multi-Array CMOS TDI Camera

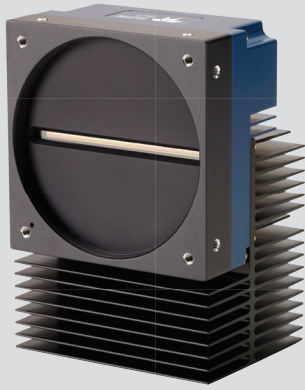

Key Features

- » High speed 100 kHz x 3
- » High sensitivity multi-array TDI
- » Capture three native colors
- » Bi-directionality
- » Next gen Camera Link HS interface

Programmability

- » Multiple Regions of Interest for calibration, data reduction
- » 8 or 12 bit output
- » Flat field and lens shading correction
- » Programmable coefficient sets

Typical Applications

- » Flat panel display inspection
- » Printed circuit board inspection
- » Semiconductor wafer
- » Life sciences
- » Web inspection
- » General purpose machine vision

High Speed and High Sensitivity Color TDI Camera

Based on Teledyne DALSA's industry leading CMOS TDI technology, the new Linea HS color camera offers the most advanced performance for color imaging in the marketplace. This camera delivers the highest speeds and highest sensitivity for many demanding color applications. The camera comes with the next-generation CLHS interface, delivering up to 8.4 Gigapixels per second over a single active optical cable.

Specifications	
Resolution	16,384 x (64+128+64) pixels
Line Rate	100 kHz x 3
Pixel Size	5 x 5 μm
Bit Depth	8 or 12 bit selectable
Lens Mount	M90 x 1
Responsivity	See graph
Dynamic Range	69 dB
Nominal Gain Range	1x ~10x
Size	97 mm x 140.5 mm x 78.6 mm
Mass	1200 g
Operating Temp	0°C to +60°C, front plate
Power Supply	+12 to +24 VDC
Power Dissipation	30 W
Data & Control	Camera Link HS, CX4
GPIO	Hironse 12-pin
Regulatory Compliance	CE, FCC, and RoHS

Camera Model

Part Number	Resolution	Max. Line Rate	Pixel Size	Output
HL-HC-16k10T	16,384 x (64+128+64) pixels	100 kHz x 3	5 x 5 μm	RGB

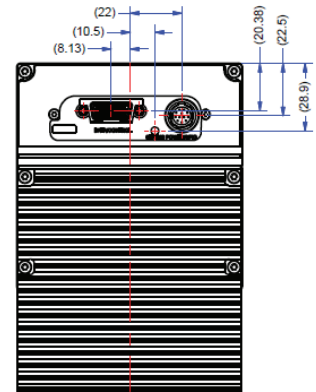
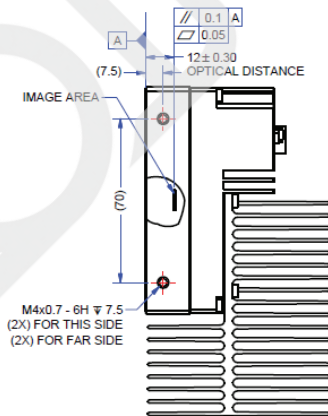
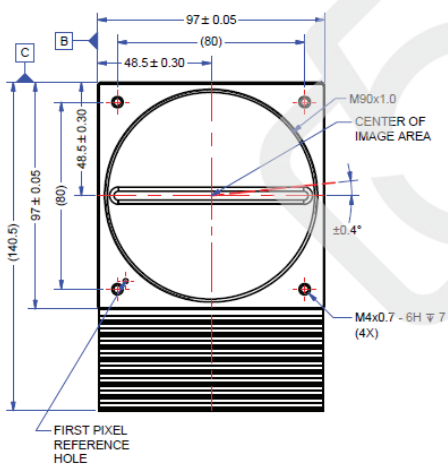
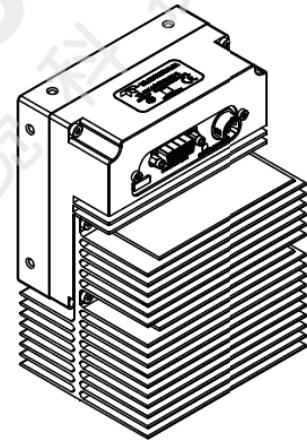
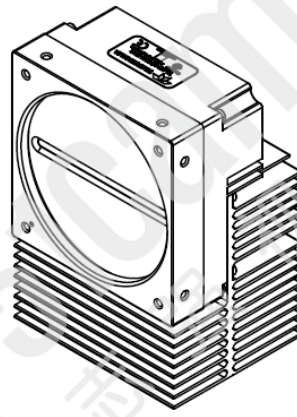
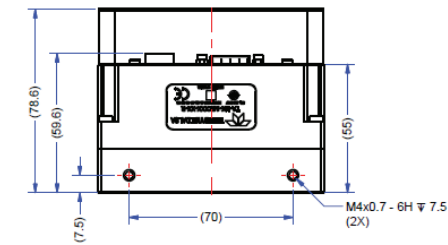
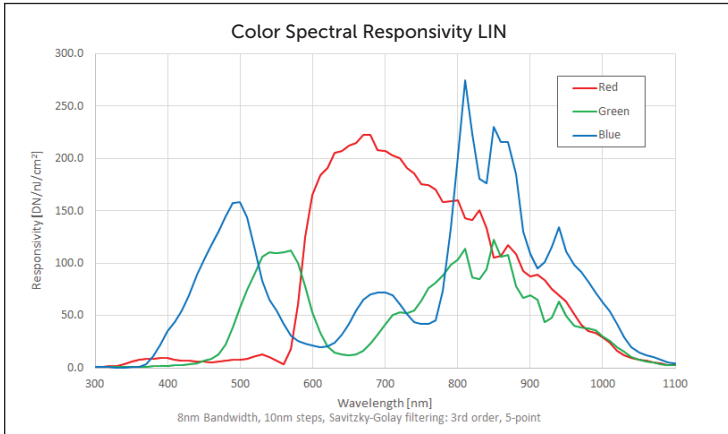

NOTES:
1. UNITS: MILLIMETERS.
2. IMAGE AREA IS ALIGNED TO DATUMS A B & C.

Americas

Boston, USA
+1 978-670-2000
sales.americas@teledynedalsa.com

Europe

Krailling, Germany
+49 89-89-54-57-3-80
sales.europe@teledynedalsa.com

Asia Pacific

Tokyo, Japan
+81 3-5960-6353
sales.asia@teledynedalsa.com

Shanghai, China
+86 21-3368-0027
sales.asia@teledynedalsa.com