

Linea™ HS

4k, 8k, 13k and 16k Monochrome / HDR CMOS TDI Cameras

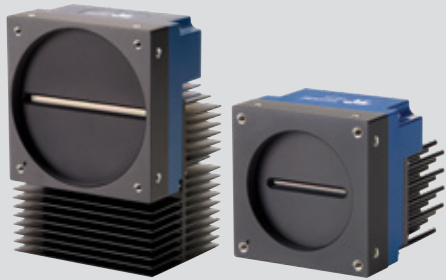

Key Features

- » High speed up to 400 kHz
- » High sensitivity
- » High dynamic range (HDR)
- » Up to 100 m optical cable length

Programmability

- » Multiple regions and areas of interest
- » 8 or 12 bit output
- » Flat field and lens shading correction
- » Programmable coefficient sets
- » GenICam™ compliant interfacing
- » Rapid coefficient changes

Typical Applications

- » Flat panel inspection
- » Gene sequencing
- » Digital pathology
- » Printed circuit board inspection
- » Web Inspection
- » Machine vision

Advanced High-Speed, High-Sensitivity TDI Camera

Based on Teledyne DALSA's industry leading CMOS TDI technology, the award-winning Linea HS™ cameras are the most advanced TDI products in the marketplace. These cameras deliver the highest performance with unique features that significantly improve detectability for many demanding applications. The cameras come with the next-generation CLHS interface, delivering up to 8.4 Gigapixels per second over a single fiberoptic cable.

Specifications	
Resolution	4,094 x 192 pixels (4k); 8,192 x 192 pixels (8k) 13,056 x 192 pixels (13k); 16,384 x 192 pixels (16k)
Line Rate	400 kHz maximum
Pixel Size	5 x 5 μm
Data Format	8 or 12 bits, selectable
Output	Monochrome / HDR
Lens Mount	M58 x 0.75 (4k, 8k) M90 x 1 (13k, 16k)
Responsivity	See graph
Dynamic Range	70 dB
Nominal Gain Range	1x to 10x
Size	76 mm x 76 mm x 85 mm (4k, 8k) 97 mm x 140.5 mm x 78.6 mm (13k, 16k)
Mass	500 g (4k, 8k) 1.2 kg (13k, 16k)
Operating Temp	0 °C to +65 °C, front plate
Power	+12 V to +24 V DC, Hirose 12-pin
Power Dissipation	<18 W (4k, 8k) <30 W (13k, 16k)
Control & Data	Camera Link HS, CX4/LC
GPIO	Direction and independent line control
Regulatory Compliance	CE, FCC, and RoHS

Camera Model

Part Number	Resolution	Max. Line Rates	Pixel Size	Output
HL-FM-04K30H-00-R	4,096 x (128+64)	300 kHz	5 μm x 5 μm	Mono/HDR
HL-FM-08K30H-00-R	8,192 x (128+64)	280 kHz	5 μm x 5 μm	Mono/HDR
HL-HM-08K30H-00-R	8,192 x (128+64)	300 kHz	5 μm x 5 μm	Mono/HDR
HL-HM-08K40H-00-R	8,192 x (128+64)	400 kHz	5 μm x 5 μm	Mono/HDR
HL-FM-13K18H-00-R	13,056 x (128+64)	180 kHz	5 μm x 5 μm	Mono/HDR
HL-HM-13K30H-00-R	13,056 x (128+64)	300 kHz	5 μm x 5 μm	Mono/HDR
HL-FM-16K15A-00-R	16,384 x 128	140 kHz	5 μm x 5 μm	Mono
HL-HM-16K30H-00-R	16,384 x (128+64)	300 kHz	5 μm x 5 μm	Mono/HDR
HL-HM-16K40H-00-R	16,384 x (128+64)	400 kHz	5 μm x 5 μm	Mono/HDR

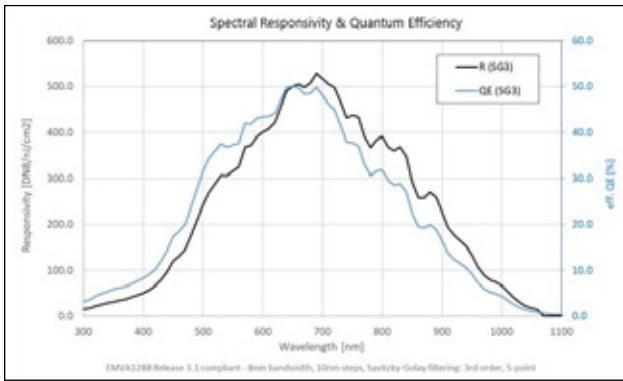

4k, 8k Model

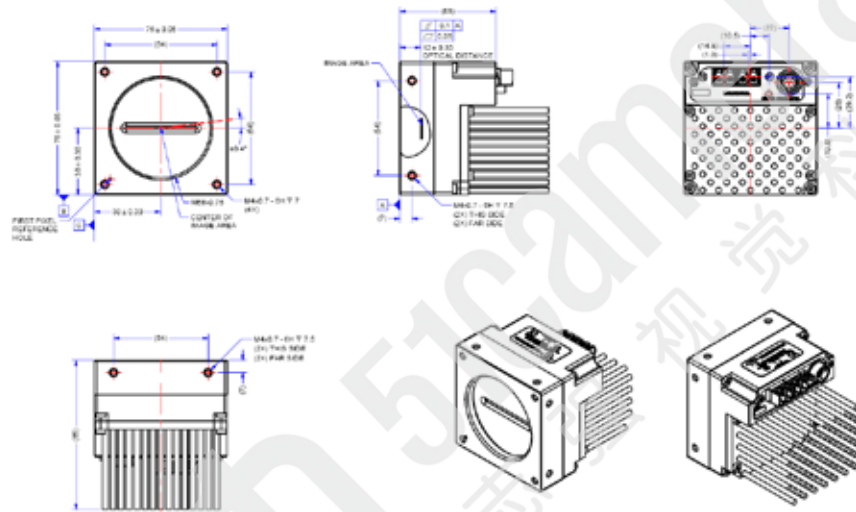

NOTES:
1. UNITS: MILLIMETERS
2. BRACKET AREA IS REFERRED TO DATUM 1

13k, 16k Model

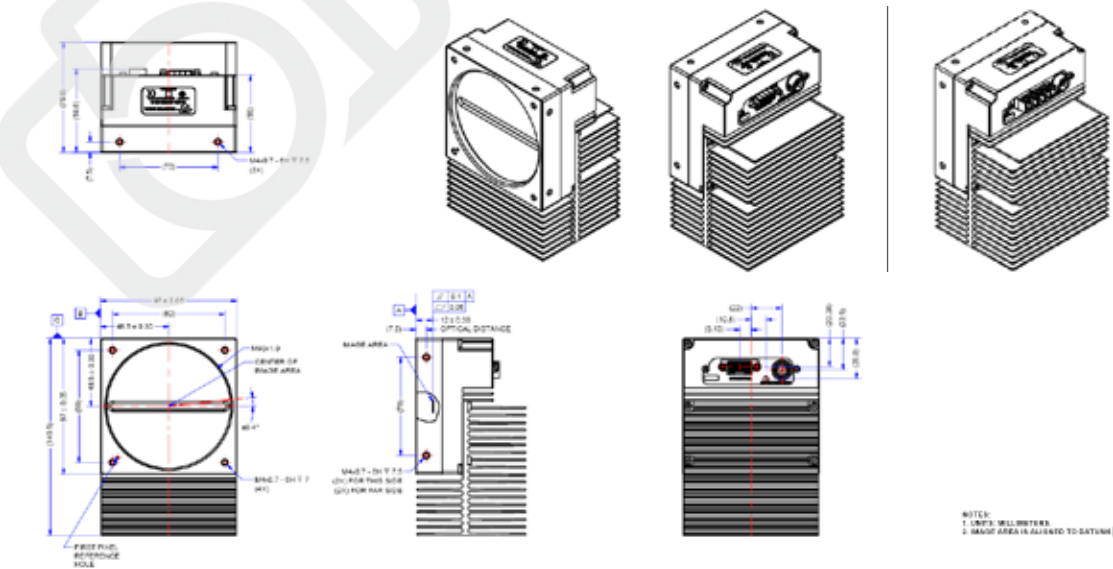

NOTES:
1. UNITS: MILLIMETERS
2. BRACKET AREA IS REFERRED TO DATUM 1

Americas
Boston, USA
+1 978-670-2000
sales.americas@teledynedalsa.com

Europe
Krailing, Germany
+49 89-89-54-57-3-80
sales.europe@teledynedalsa.com

Asia Pacific
Tokyo, Japan
+81 3-5960-6353
sales.asia@teledynedalsa.com

Shanghai, China
+86 21-3368-0027
sales.asia@teledynedalsa.com