

Piranha4 4K and 2K

High Speed Dual Line CMOS Cameras

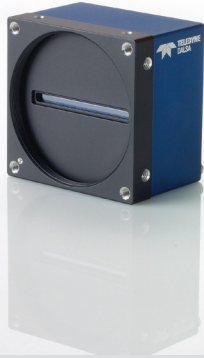

Key Features

- High speed: up to 100 kHz in TDI mode and 200 kHz in area mode
- Independent exposure control for each line (HDR)
- Permits longer Camera Link cables
- Compact camera body

Programmability

- Multiple Regions of Interest for calibration and data reduction
- 8, 10 or 12 bit output
- Smart flat field and lens shading correction
- 8 programmable coefficient sets
- GenICam or ASCII compliant interfacing

Typical Applications

- Automated optical inspection
- Transportation safety and security systems
- High performance sorting systems
- Materials grading and inspection systems
- Web inspection
- General purpose machine vision

Regulatory Compliance

- CE, FCC and RoHS

Fast 100 kHz in TDI mode and 200 kHz in area mode!

Teledyne DALSA expands its Piranha4 dual line CMOS camera family with 4K and 2K resolution models. The new Piranha4 models offer higher speeds and more responsive pixels in a choice of sizes and resolutions. Programmable features include multiple region-of-interest, high dynamic range operation, and rapid bi-directional switching, and are designed to meet today's demanding imaging applications.

Specifications

Resolution	4096 x 2 and 2048 x 2 pixels
Line Rate	Up to 100 kHz in TDI mode (200 kHz in area mode)
Pixel Size	10.56 μm x 10.56 μm
Data Format	8, 10 or 12 bit selectable
Output	Base, Medium, Full and Deca Camera Link
Lens Mount	M58 x 0.75 (4k) and M42 x 1 (2k) F-mount adapter available
Responsivity	1400 DN / (nJ / cm ²) in 12 bit at 1x gain
Dynamic Range	> 60 dB
Nominal Gain Range	1x to 10x
Size	62 mm x 62 mm x 48 mm
Mass	< 340 g
Operating Temp	0 °C to 65 °C (front plate)
Power	Hirose 6-pin male
Power Dissipation	< 11 W (4k) and < 8.3 W (2k)
Control & Data	SDR-26 mini Camera Link

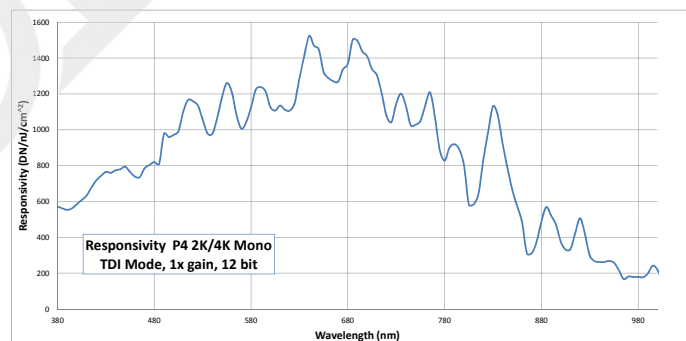

Piranha4 Dual Line Models			
Part Number	Resolution	Maximum Line Rates TDI mode (area mode)	Pixel Size
P4-CM-04K10D-00-R	4096 x 2 pixels	100 kHz (200 kHz)	10.56 μm x 10.56 μm
P4-CM-04K05D-00-R	4096 x 2 pixels	50 kHz (100 kHz)	10.56 μm x 10.56 μm
P4-CM-02K10D-00-R	2048 x 2 pixels	100 kHz (200 kHz)	10.56 μm x 10.56 μm
P4-CM-02K05D-00-R	2048 x 2 pixels	50 kHz (100 kHz)	10.56 μm x 10.56 μm

Piranha4 4K and 2K

High Speed Dual Line CMOS Cameras

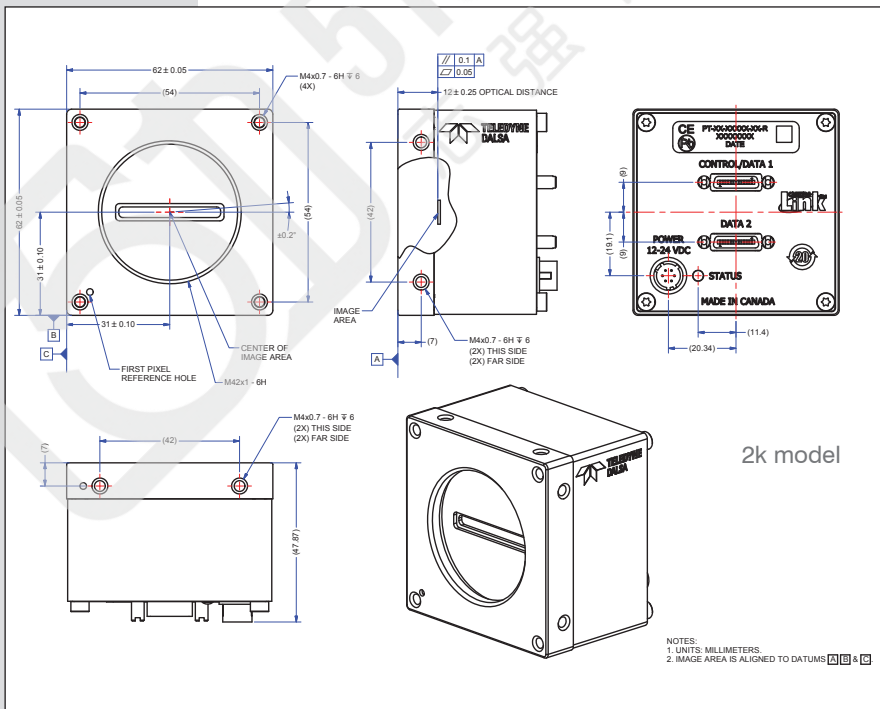
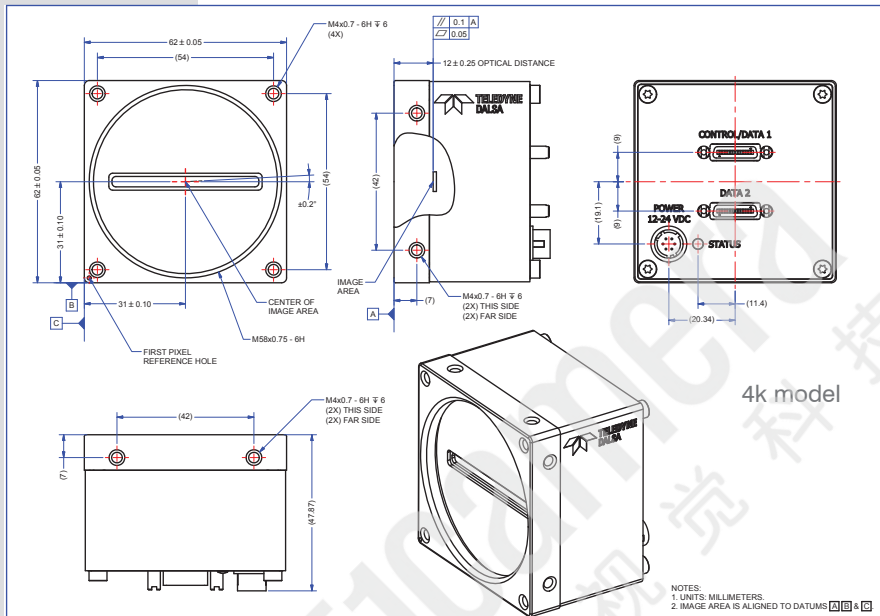

www.teledynedalsa.com

Americas

Boston, USA
+1 978-670-2000
sales.americas@teledynedalsa.com

Europe

Krailling, Germany
+49 89-89-54-57-3-80
sales.europe@teledynedalsa.com

Asia Pacific

Tokyo, Japan
+81 3-5960-6353
sales.asia@teledynedalsa.com

Shanghai, China
+86 21-3368-0027
sales.asia@teledynedalsa.com

Teledyne DALSA has its corporate offices in Waterloo, Canada
Teledyne DALSA reserves the right to make changes at any time without notice. Teledyne DALSA © 2013.
Revision number 03-070-20066-01. Revision date September 05 2013.

