

Piranha HS-S0-06K80-00-R

High Sensitivity Line Scan Cameras



6k resolution and 142 kHz line rate

The Piranha HS 6k camera with a maximum line rate of 142 kHz is the newest member of the HS family of high sensitivity line scan cameras.

The HS 6k camera is capable of bidirectional operation with up to 256 stages of selectability, while preventing overexposure with antiblooming features. Camera configuration is flexible and all software is controllable.

Key Features

- 6,000 pixels
- 10.4 μm pixel size
- Max 142 kHz line rate
- Responsivity 1200 DN/(nJ/cm²) @ 0 dB, 8 bit
- Bidirectional
- Antiblooming
- HSLink interface

Programmability

- Up to 256 TDI stages selectable
- Selectable area mode of operation for ease of alignment
- Up to four sets of flat field correction coefficients
- Mirroring and forward/reverse control
- Flat field corrections

Typical Applications

- Wafer inspection
- Flat panel display inspection
- PCB/electronics inspection
- Large web applications
- High performance document scanning
- Low light applications

Specifications

Resolution	6,000 x 256 pixels TDI
Data Rate	Up to 852 Mpix/s
Max. Line/Frame Rate	142 kHz
Pixel Size	10.4 μm x 10.4 μm
Data Format	8, 10, or 12 bit
Output	HSLink
Lens Mount	M72 x 0.75
Responsivity	1200 DN/(nJ/cm ²) at 0 dB, 8 bit
Dynamic Range	1024 : 1 (typical at 0 db, 10 and 12 bit)
Nominal Gain Range	0 dB to 20 dB
Size	180 mm (H) x 90 mm (W) x 92.1 mm (D)
Mass	< 1500 g
Operating Temp	0 °C to 50 °C
Power Supply	24 VDC
Power Dissipation	< 45 W
Regulatory Compliance	RoHS and CE
Control	HSLink
Data	Shared with Control
Power	Lemo 2 pin
Example Part Number	HS-S0-06k80-00-R

Piranha HS-S0-06K80-00-R

High Sensitivity Line Scan Cameras

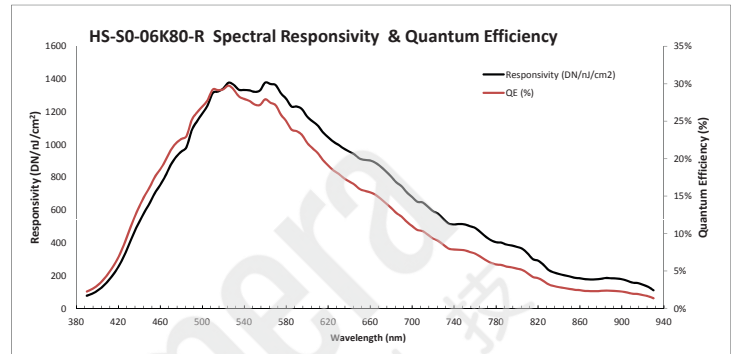

*Settings 0 dB gain and 8-bit

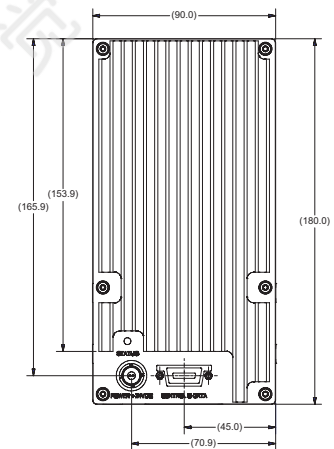
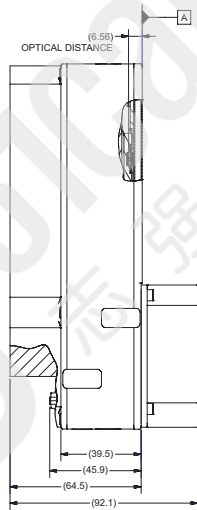
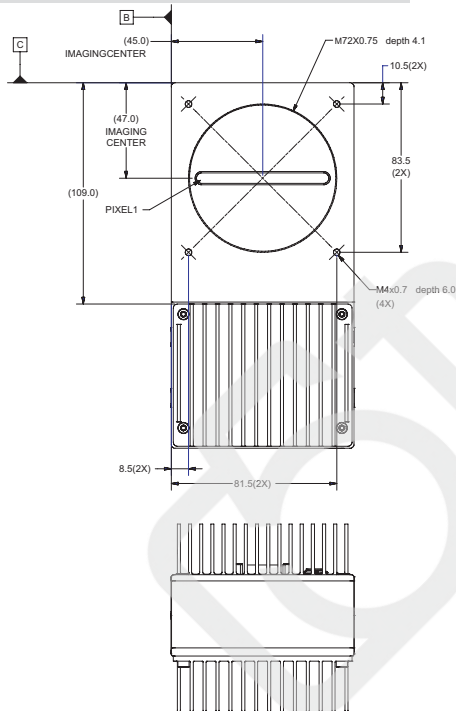

Notes:

- 1) Imaging area aligned in X-Y with respect to datums B and C.
- 2) Rotation of the CCD imaging area is ± 0.6 degrees.
- 3) Lens mount position with respect to imaging area: X-Y ± 0.175 MM.
- 4) Imaging area position tolerances are to be determined.
- 5) Units: MM.

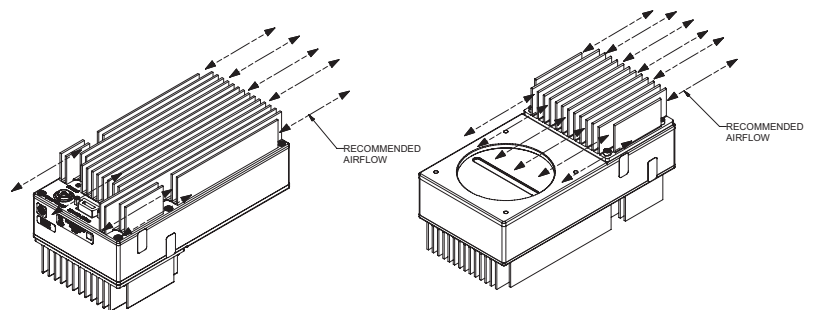

www.teledynedalsa.com

Americas

Boston, USA
 +1 978-670-2000
sales.americas@teledynedalsa.com

Europe

Krailling, Germany
 +49 89-89-54-57-3-80
sales.europe@teledynedalsa.com

Asia Pacific

Tokyo, Japan
 +81 3-5960-6353
sales.asia@teledynedalsa.com

Shanghai, China
 +86 21-3368-0027
sales.asia@teledynedalsa.com