

Lt1265R

12.0 Megapixel, High Sensitivity, CCD
Camera with High-Speed USB 3.0



High Resolution, Low Noise CCD Imaging

The Lt1265R is Lumenera's latest innovative, high performance USB 3.0 CCD camera based on the solid design of the Lt365R, Lt665R and Lt965R cameras. The Lt1265R builds on leading edge EXview HAD II technology to deliver high sensitivity, low noise and high dynamic range. High grade electronics ensure clear, sharp and low noise images that render details with amazing accuracy. Superior responsivity up to 1000nm positions it as a good choice for Near-Infrared (NIR) imaging. This industrial-grade camera is ideally suited for a variety of applications including unmanned vehicles, surveillance, traffic, tolling, high-speed inspection and machine vision. A scientific-grade variant is available for the most demanding life science applications such as ophthalmology and fluorescence. The Lt1265R can also be customized to suit OEM designs.

High Quality Images at High Speed

The Lt1265R was created with the latest USB 3.0 technology to deliver the fastest image delivery possible from the Sony ICX834 sensor at its highest resolution. Image captures can be synchronized using either a hardware or software trigger. FPGA-enabled performance, complemented by 128 MB of onboard memory for frame buffering, ensure dependable and reliable image delivery even in the most demanding machine vision systems. Unlike some competitive cameras, the Lt1265R buffer technology delivers all frames at full speed and max resolution without introducing latency.

Plug-and-Play with No Framegrabber

The compact, robust design of this camera, measuring 43 x 43 x 65 mm, allows for easy integration into tight spaces and systems. The locking USB 3.0 cabling and digital interface ensure a simple plug-and-play installation. No framegrabber is required. Simplified I/O cabling is provided through a locking Hirose connector supporting external power input along with 1 optically isolated output, 1 optically isolated input and 2 configurable I/O ports. Lumenera's innovative design supports an optional USB 3.0 High Power mode that allows the camera to function over a USB 3.0 Y-cable connected to 2 host USB 3.0 ports thus eliminating the need to use a power supply.

Maximize Camera Performance Within Your Own Application

The Lumenera Camera SDK provides a full suite of features and functions that allow you to maximize the camera's performance within your own vision application with minimal work. The SDK is compatible with all of our USB and GigE-based cameras. Microsoft DirectX/DirectShow, Windows API and .NET API interfaces are provided, allowing you the choice of application development environments from C/C++ to VB.NET or C#.NET.

Superior Technical Assistance Center

All Lumenera cameras are supported by an experienced team of pre-sales and technical support imaging experts widely acclaimed in the industry. We understand your imaging needs and are here to help you get the most out of your camera.

Features

- Industry leading Sony EXview HAD II sensor technology
- Quad-Tap mode supports 15 fps at full resolution
- Color or monochrome CCD sensor with 1" optical format providing a resolution of 4240 x 2832 using 3.1 x 3.1 μm pixels
- High-Speed USB 3.0 interface for fastest image delivery and simplified connectivity
- Compact, robust form factor measuring 43 x 43 x 65 mm with 4 mounting points on all 4 sides and 1 tripod (1/4"-20) mount
- Locking industrial micro USB 3.0 and Hirose GPIO connector for power and control of peripherals and synchronization of lighting
- 4 GPI/O: 1 optically isolated output, 1 optically isolated input and 2 configurable bi-directional I/O ports
- 128 MB RAM frame buffer
- Simplified cabling – video, full camera control and power over a single locking micro USB 3.0 cable
- Region of Interest (ROI) option to provide higher frame rates
- Selectable 8 or 14-bit pixel data
- Excellent tap matching calibration for seamless images
- Multiple data rates supported, each optimized for lowest noise performance
- FCC Class B, CE Certified
- DirectShow compatible
- Software compatible with Windows 10, Windows 8.1, Windows 7, Linux, 32 and 64-bit operating systems
- Complete SDK available for Windows and Linux platforms
- Four (4) year warranty



Color Quantum Efficiency Curves

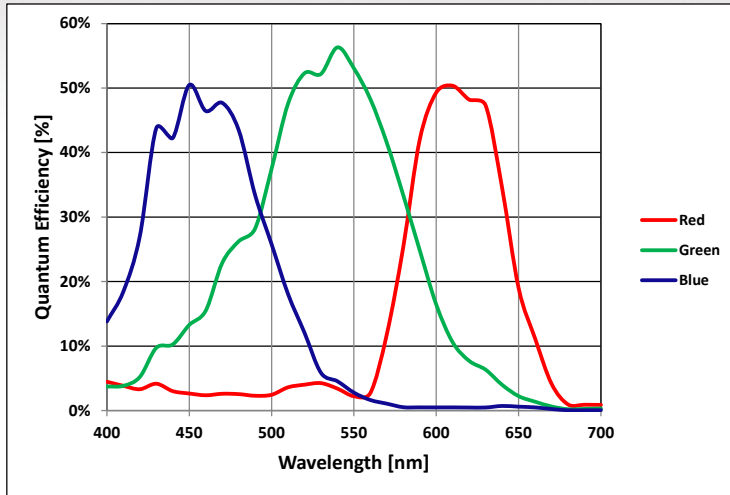

Monochrome Quantum Efficiency Curve

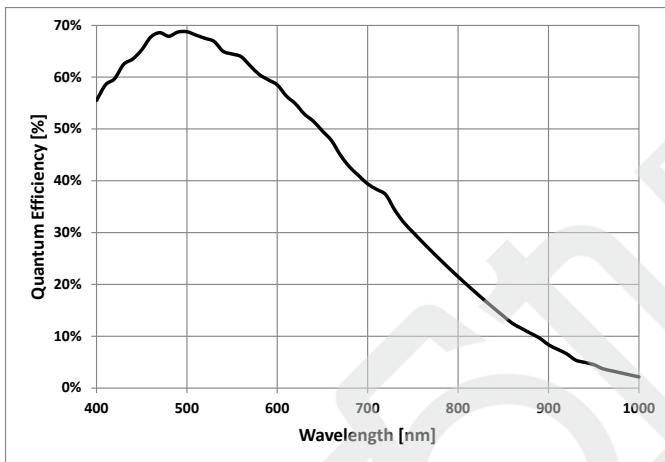

Recommended Applications

- UAV, Aerial Imaging
- ITS (Intelligent traffic solutions)
- High Resolution Surveillance
- Machine Vision Inspection
- High Resolution Fluorescence Imaging
- Whole Slide Imaging
- Large Area Scan

Sensor Specifications	
Image Sensor	Sony ICX834, CCD, color, monochrome
Optical Format	1"
Imager Size	Diagonal 15.80 mm
Pixel Size	3.1 x 3.1 μm
Resolution	4240 x 2832 pixels
Region of Interest Control	Any multiple of 16 x 16 (quad tap mode)
Camera Specifications	
Max Frame Rate	15 fps at 4240 x 2832
Bit Depth	8 or 14-bit
Binning Modes	2 x 2, 4 x 4, 8 x 8 (3 x 3 mono only)
Exposure Control	Manual and automatic control
Exposure Range	3 μs to 71 min (snapshot) 39 μs to 2.17 s (video)
Gain Control	Manual and automatic control
Gain Range	0.5 to 37 x
White Balance	Manual and automatic control
Trigger Modes	Hardware and software triggerable
Camera Characteristics	
Sensitivity	Mono: 4.0 DN/(nJ/cm ²), Color: 3.4 DN/(nJ/cm ²) (Global and channel gains at unity)
Dynamic Range	~60 dB
Full Well Capacity	~8,000 e-
Quantum Efficiency	56% @ 540 nm peak color, 69% @ 500 nm peak mono
Read Noise	~7.7e- (Quad-Tap mode)
Dark Current Noise	<1 e-/s (at 22 °C ambient, 41 °C internal)
Mechanical Specifications	
Data Interface	USB 3.0, micro locking connector
General Purpose I/O	Locking Hirose MXR-8R-8SA(71)
Lens Mount	C-Mount
Dimensions	43 x 43 x 65 mm
Mass	175 g
Operating Temperature	0 to 50 °C
Storage Temperature	-30 to 70 °C
Operating Humidity	5 to 95 %, non-condensing
Shock / Vibration	50 G shock / 5 G (2 to 200 Hz) vibration
Onboard Memory	Camera has onboard non-volatile memory storage
Camera Software	
Operating Systems	Windows 10, Windows 8.1, Windows 7, Linux, 32 and 64-bit operating systems
Software Interfaces	DirectShow
Power and Emissions	
Power Consumption	6.0 W (Max)
Power Requirement	USB Y cable or, La2000PK or La2000PIOK power kit to provide 5 V DC, 1.5 A, power through GPIO.
Emissions Compliances	FCC Class B, CE Certified
Hazardous Materials	RoHS, WEEE Compliant
Warranty	Four (4) years
Ordering Options	
Lt1265RM	12.0 MP Monochrome Camera
Lt1265RC	12.0 MP Color Camera
La2000PK	Power Supply via GPIO connector (power only)
La2000PIOK	Power Supply with GPIO cable (leads + power)
LuSDK	Software Developer's Kit (Web Download)
LuSDKSW-DVD	Software Developer's Kit (DVD)
Customization Options	
-SCI	Scientific grade
-WOIR	AR/AR glass within lens mount



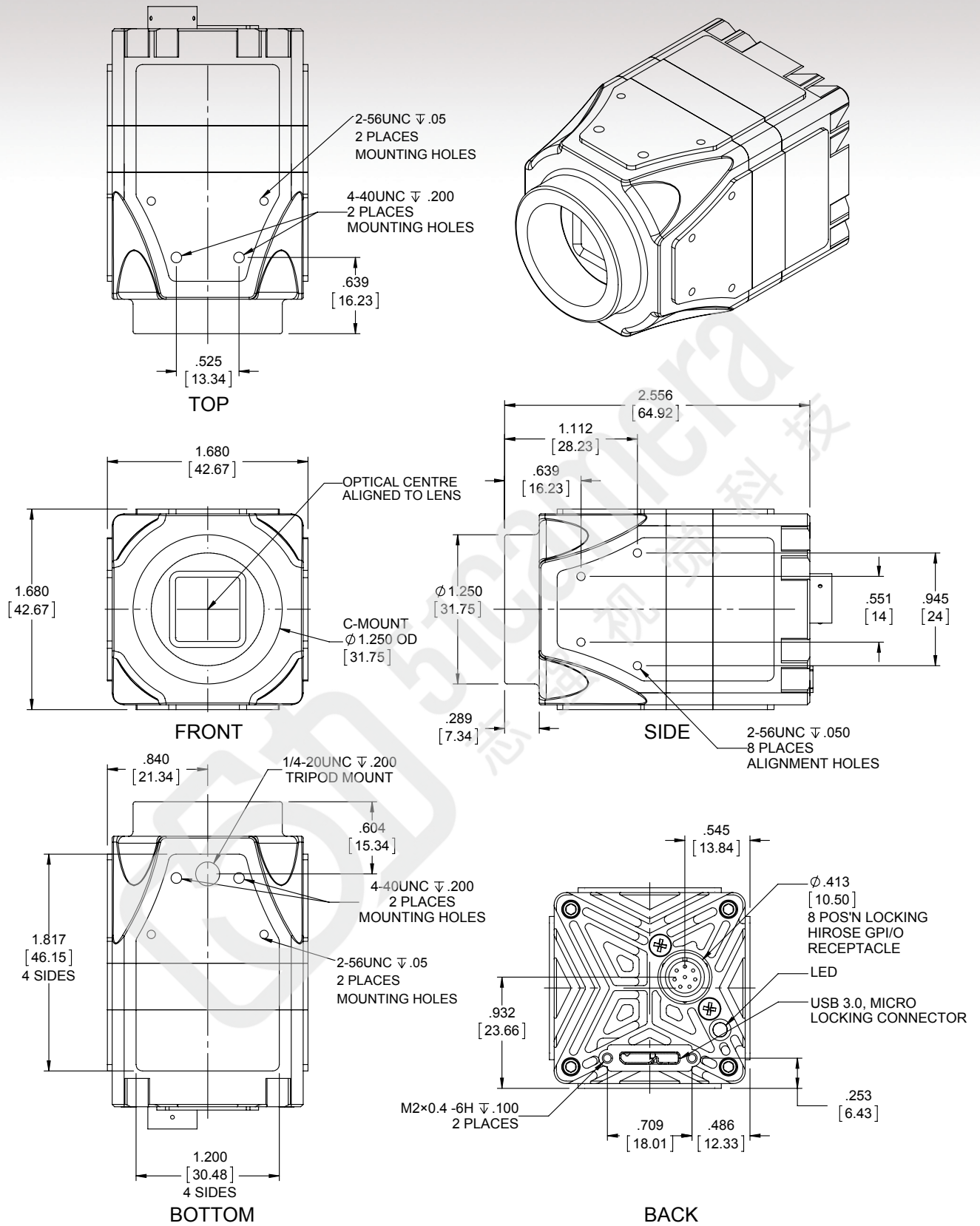

ALL DIMENSIONS DISPLAYED AS INCHES [MM]

