

# Lt965R

9.1 Megapixel, High Sensitivity, CCD Camera with High-Speed USB 3.0



## High Resolution, Low Noise CCD Imaging

The Lt965R is Lumenera's latest innovative, high performance USB 3.0 CCD camera based on the solid design of the Lt365R and Lt665R cameras. The Lt965R builds on leading edge ExView HAD II technology to deliver high sensitivity, low dark current and excellent anti-blooming characteristics. Low noise electronics ensure clear and sharp images rendering details with amazing accuracy. Superior responsiveness positions it as a good choice for Near-Infrared (NIR) imaging. This industrial-grade camera is ideally suited for a variety of applications including surveillance, traffic, tolling, high-speed inspection and machine vision. A scientific-grade variant is available for the most demanding life science applications such as ophthalmology and fluorescence. The Lt965R can also be customized to suit OEM designs.

## High Quality Images at High Speed

The Lt965R was created for speed using the latest USB 3.0 technology to deliver the fastest image delivery possible from the Sony ICX814 sensor at its highest resolution. Image captures can be synchronized using either a hardware or software trigger. FPGA-enabled performance, complemented by 128 MB of onboard memory for frame buffering, ensure dependable and reliable image delivery even in the most demanding machine vision systems. Unlike some competitive cameras, the Lt965R buffer technology delivers all frames at full speed and max resolution without introducing latency.

## Plug-and-Play with No Framegrabber

The compact, robust design of this camera, measuring 43 x 43 x 65 mm, allows for easy integration into tight spaces and systems. The locking USB 3.0 cabling and digital interface ensure a simple plug-and-play installation. No framegrabber is required. Simplified I/O cabling is provided through a locking Hirose connector supporting external power input along with 1 optically isolated output, 1 optically isolated input and 2 configurable I/O ports.

## Maximize Camera Performance Within Your Own Application

The Lumenera Camera SDK provides a full suite of features and functions that allow you to maximize the camera's performance within your own vision application with minimal work. The SDK is compatible with all of our USB and GigE-based cameras. Microsoft DirectX/DirectShow, Windows API and .NET API interfaces are provided, allowing you the choice of application development environments from C/C++ to VB.NET or C#.NET.

## Superior Technical Assistance Center

All Lumenera cameras are supported by an experienced team of pre-sales and technical support imaging experts widely acclaimed in the industry. We understand your imaging needs and are here to help you get the most out of your camera.



## Features

- Industry leading Sony ExView HAD II sensor technology
- Fastest camera using the ICX814 sensor: 19 fps at full resolution on USB 3.0
- Color or monochrome CCD sensor with 1" optical format providing a resolution of 3376 x 2704 using 3.69 x 3.69 µm pixels
- High-Speed USB 3.0 interface for fastest image delivery and simplified connectivity
- Compact, robust form factor measuring 43 x 43 x 65 mm with 4 mounting points on all 4 sides and 1 tripod (1/4"-20) mount
- Locking industrial micro USB and Hirose GPI/O connector for power and control of peripherals and synchronization of lighting
- 4 GPI/O: 1 optically isolated output, 1 optically isolated input and 2 configurable I/O ports
- 128 MB RAM frame buffer
- Simplified cabling – video and full camera control over a single locking micro USB 3.0 cable
- Region of Interest (ROI) option to provide higher frame rates
- Selectable 8 or 14-bit pixel data
- Selectable tap readout to match sensor performance to your application
- Multiple data rates supported, each optimized for lowest noise performance
- FCC Class B, CE Certified
- DirectShow compatible
- Software compatible with Windows 10, Windows 8.1, Windows 7, Linux, 32 and 64-bit operating systems
- Complete Windows and Linux SDKs available
- Four (4) year warranty

Color Quantum Efficiency Curves

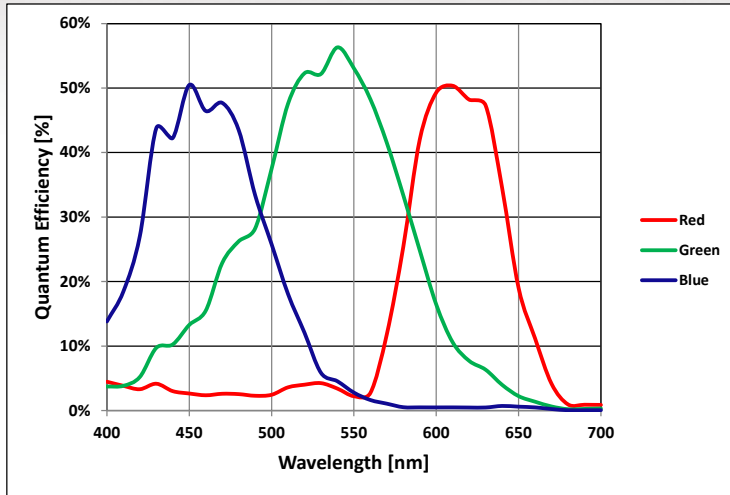

Monochrome Quantum Efficiency Curve

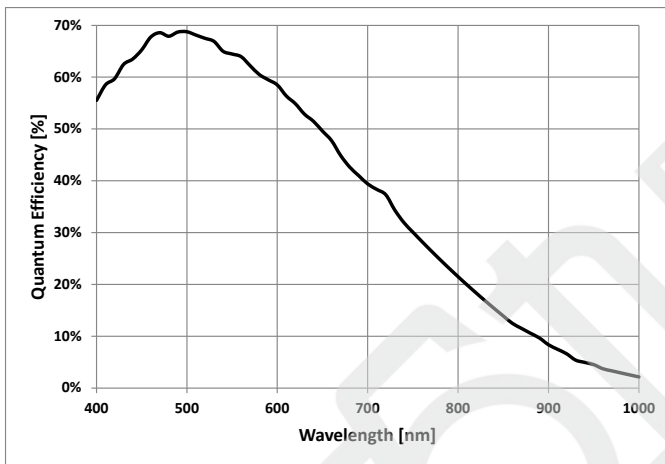

### Recommended Applications

- UAV, Aerial Imaging
- Hyperspectral Imaging
- High Resolution Surveillance
- Machine Vision Inspection
- High Resolution Fluorescence Imaging
- Whole Slide Imaging
- Large Area Scan
- ITS (Intelligent traffic solutions)

Sensor Specifications	
Image Sensor	Sony ICX814, CCD, color, monochrome
Optical Format	1"
Imager Size	Diagonal 15.99 mm
Pixel Size	3.69 x 3.69 $\mu\text{m}$
Resolution	3376 x 2704 pixels
Region of Interest Control	Any multiple of 16 x 16 (quad tap mode)
Camera Specifications	
Max Frame Rate	19 fps at 3376 x 2704, 33 fps with 2x2 binning
Bit Depth	8 or 14-bit
Binning Modes	2 x 2, 4 x 4, 8 x 8 (3 x 3 mono only)
Exposure Control	Manual and automatic control
Exposure Range	3 $\mu\text{s}$ to 71 min (snapshot) 39 $\mu\text{s}$ to 2.17 s (video)
Gain Control	Manual and automatic control
Gain Range	0.5 to 37 x
White Balance	Manual and automatic control
Trigger Modes	Hardware and software triggerable
Camera Characteristics	
Sensitivity	Mono: 4.7 DN/(nJ/cm <sup>2</sup> ), Color: 4.0 DN/(nJ/cm <sup>2</sup> ) (Global and channel gains at unity)
Dynamic Range	~65 dB
Full Well Capacity	~12,000 e-
Quantum Efficiency	56% @ 540 nm peak color, 69% @ 500 nm peak mono
Read Noise	~6.8e- (Quad-Tap mode)
Dark Current Noise	<1 e-/s (at 22 °C ambient, 41 °C internal)
Mechanical Specifications	
Data Interface	USB 3.0, micro locking connector
General Purpose I/O	Locking Hirose MXR-8R-8SA(71)
Lens Mount	C-Mount
Dimensions	43 x 43 x 65 mm
Mass	175 g
Operating Temperature	0 to 50 °C
Storage Temperature	-30 to 70 °C
Operating Humidity	5 to 95 %, non-condensing
Shock / Vibration	50 G shock / 5 G (2 to 200 Hz) vibration
Onboard Memory	Camera has onboard non-volatile memory storage
Camera Software	
Operating Systems	Windows 10, Windows 8.1, Windows 7, Linux, 32 and 64-bit operating systems
Software Interfaces	DirectShow
Power and Emissions	
Power Consumption	6.0 W
Power Requirement	USB Y cable or, La2000PK or La2000PIOK power kit to provide 5 V DC, 1.5 A, power through GPIO.
Emissions Compliances	FCC Class B, CE Certified
Hazardous Materials	RoHS, WEEE Compliant
Ordering Options	
Lt965RM	9.1 MP Monochrome Camera
Lt965RC	9.1 MP Color Camera
La2000PK	Power Supply via GPIO connector (power only)
La2000PIOK	Power Supply with GPIO cable (leads + power)
LuSDK	Software Developer's Kit (Web Download)
Customization Options	
-SCI	Scientific grade
-WOIR	AR/AR glass within lens mount



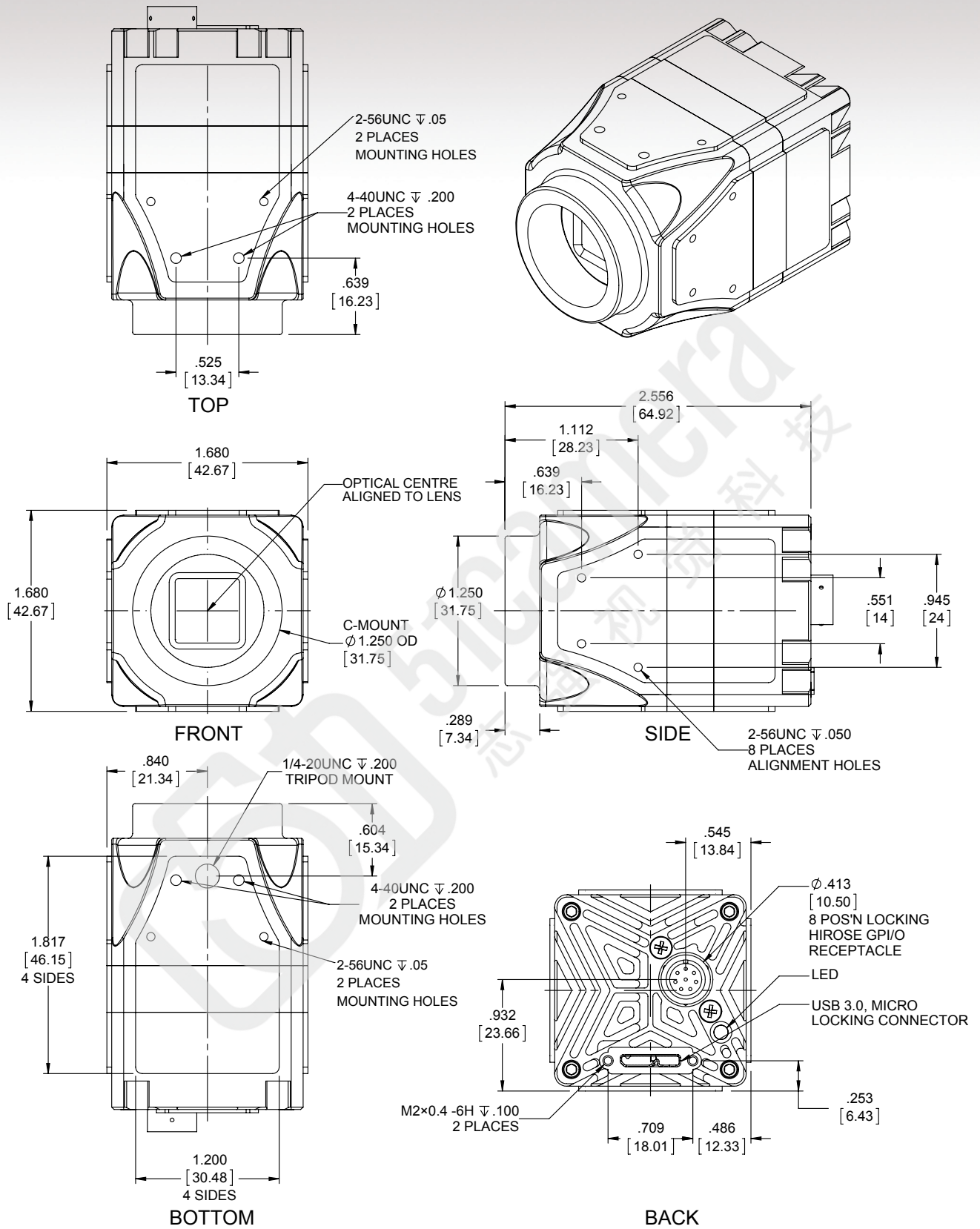

ALL DIMENSIONS DISPLAYED AS INCHES [MM]

