

# Genie™ NanoXL-C5100

Area Scan Color Cameras



## Key Features

- Uses standard PC Ethernet port & hardware
- Supports cable lengths up to 100 m (CAT-5e or CAT-6)
- Simplified set-up with field proven Sapera Essential software featuring CamExpert
- Engineered to accommodate industrial environment with a Ruggedize, screw mount, RJ-45 connector

## Programmability

- Higher frame rates achievable in partial scan mode
- Global electronic shutter with exposure Control
- Multi-Exposure Feature

## Typical Applications

- Electronics manufacturing inspection
- Industrial metrology
- Intelligent traffic systems

## Regulatory Compliance

- CE, FCC and RoHS

## Overview

# Compact GigE Vision camera with very high resolution.

The Genie NanoXL-C5100 offers the On-Semi Python 25K Color version sensor with a resolution of 5120 x 5120. Teledyne DALSA's "Burst Acquisition" and "Turbo Drive" feature allows for image capture rates of 20 fps in 25 Mpixels resolution while maintaining very good image quality. The Genie NanoXL-C5100 takes advantage of gigabit Ethernet technology, transmitting data over standard CAT-5e and CAT-6 cables to distances of up to 100 m. Like all Teledyne DALSA GigE cameras, the Genie NanoXL-C5100 is based on AIA (Automated Imaging Association) GigE Vision Standard to directly link the camera to a PC.



## Specifications

Active Resolution	5120 x 5120
Acquisition Frame Rate	Up to 20 fps (internal BurstMode)
Data Output Transfer	Gigabit Ethernet (1000 Mbit/s) only
Pixel Size	4.5 $\mu\text{m}$ x 4.5 $\mu\text{m}$
Data Format	8 or 10-Bits output
Exposure Control	Automatic, Programmable, or via External Trigger
Dynamic Range	55.2 dB
Gain Control	Automatic, Manual up to 3.17x analog gain
I/O Ports	2 opto-isolated input, 3 opto-isolated output
Image Buffer	500 MB of On-board memory
Lens Mount	M42 mount
Size (L x H x W)	30 mm x 59 mm x 59 mm (without lens adapter or connectors)
Mass	~163g
Operating Temp	-20 to +60c (Housing temperature)
Power Supply	10 to 36V or Power Over Ethernet (POE)
Power Dissipation	6.5 Watt @ 24Volt Aux.
Data Connector	Standard or Screw mount RJ-45
Power and I/O Connector	SAMTEC TFM-105 type
Camera Specification	GigE Vision v1.2 Compliant
Software Platform	Teledyne DALSA Sapera LT 8.0 or 3rd Party Genicam Compliant SDK
Part Number	G3-GC30-C5105

# Genie™ NanoXL-C5100

## Area Scan Color Cameras

All Genie cameras feature value added functionality designed specifically for imaging and machine vision applications. All features are easily accessible with Teledyne DALSA's advanced software tools. These tools deliver superior image capture, performance, and control.

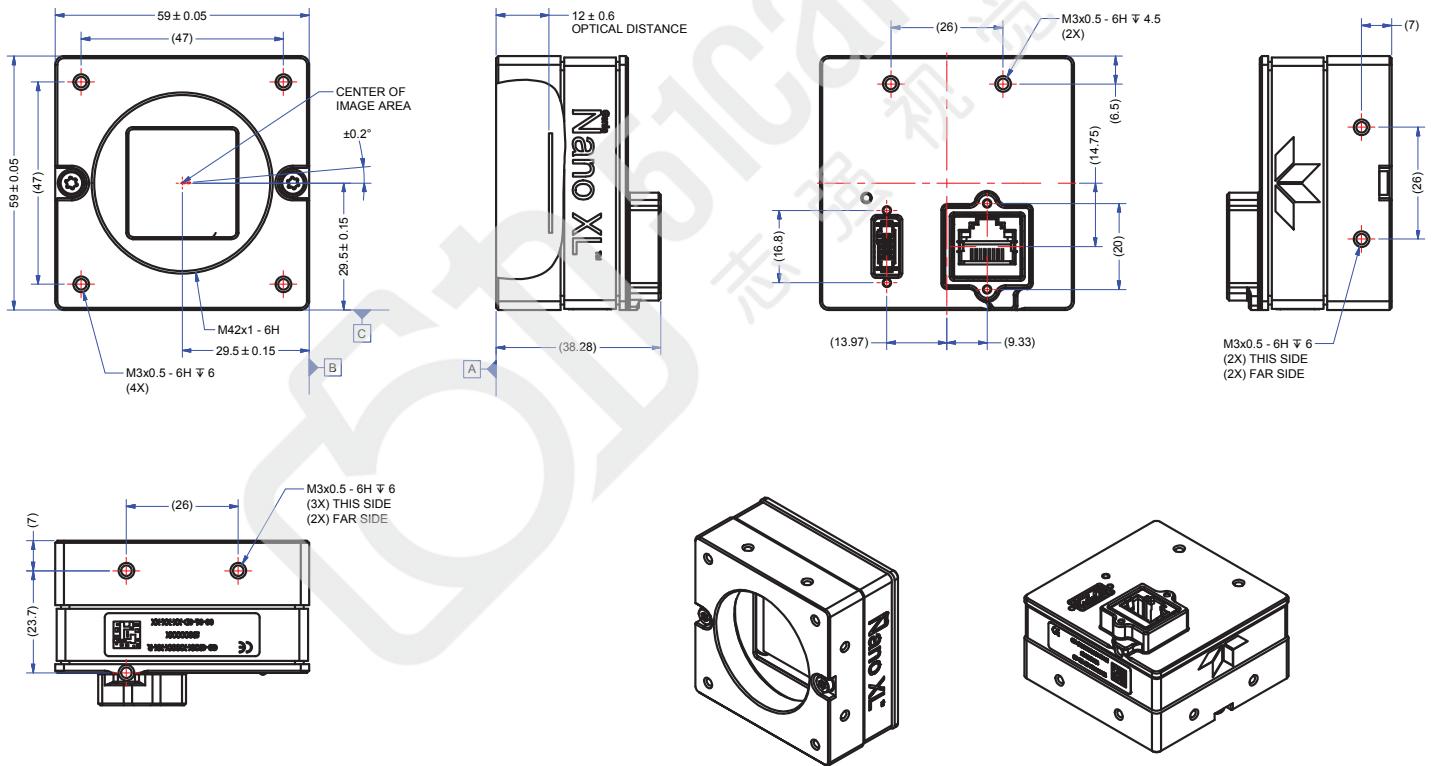
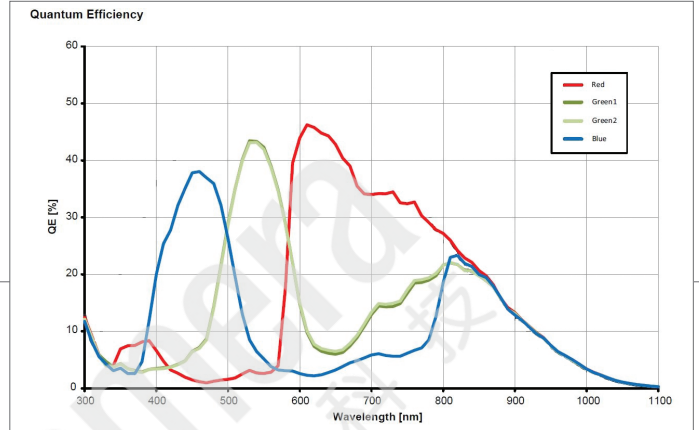

[www.teledynedalsa.com](http://www.teledynedalsa.com)

### Americas

Boston, USA  
+1 978-670-2000  
sales.americas@teledynedalsa.com

### Europe

Krailling, Germany  
+49 89-89-54-57-3-80  
sales.europe@teledynedalsa.com

### Asia Pacific

Tokyo, Japan  
+81 3-5960-6353  
sales.asia@teledynedalsa.com

Shanghai, China  
+86 21-3368-0027  
sales.asia@teledynedalsa.com

Teledyne DALSA has its corporate offices in Waterloo, Canada  
Teledyne DALSA reserves the right to make changes at any time without notice. Teledyne DALSA © 2017.

