VA-1MC / VA-2MC

VA-4MC / VA-8MC

VA-16MC / VA-29MC

1 / 2 / 4 / 8 / 16 / 29 MEGAPIXEL RESOLUTION

HIGH-SPEED PROGRAMMABLE DIGITAL CAMERA



VA Series cameras are progressive scan high performance digital cameras based on the 5.5 μm 4-tap CCD sensor technology of ON Semiconductor (formerly Truesense Imaging, Inc.). ON Semiconductor's 4-tap readout structure results in 2 \times the frame rate as compared to previous generation image sensors. Frame rates as high as 125 frames per second at 1 million pixel resolution can be achieved. This camera series is ideal for demanding applications such as semi-conductor inspection, electronics inspection, aerial imaging inspection, and FPD inspection.

VIEWWORKS

VA-1MC / VA-2MC / VA-4MC / VA-8MC / VA-16MC / VA-29MC

1 / 2 / 4 / 8 / 16 / 29 MEGAPIXEL RESOLUTION – HIGH-SPEED PROGRAMMABLE DIGITAL CAMERA

Main Features

- * ON Semiconductor Progressive Scan IT CCD Imager
- * 14 bit A/D Converter
- * 8/10/12 bit Data Output
- * 1/2/4 Tap for Full Resolution Readout from 4.8 up to 120 fps
- * Field Upgradable Firmware
- * Flat Field Correction
- * Pixel Defect Correction
- * Excellent Anti-blooming and Anti-smear

Applications

- * Machine Vision Inspection
- * Research and Scientific Imaging
- * Microscopy and Metrology
- * Remote Sensing and Scanning
- * Intelligent Transport System (ITS)

Specifications

Model	VA-1MC-M/C 120	VA-2MC-M/C 68	VA-4MC-M/C 32
Resolution (H × V)	1024 × 1024	1600 × 1200	2336 × 1752
Sensor (ON Semiconductor)	KAI-01050	KAI-02050	KAI-04050
Sensor Size (Optical Format)	1/2"	2/3"	1"
Sensor Type	Progressive Scan Interline Transfer CCD		
Pixel Size	5.5 μm × 5.5 μm		
Sensor Output	1, 2 or 4 Tap		
Interface	Camera Link		
Max. Frame Rate	125 fps	70 fps	33 fps
Exposure Time	1/100000 ~ 7 s (10 μs step)		
Partial Scan (Max. Speed)	337 fps at 120 Lines	183 fps at 150 Lines	142 fps at 200 Lines
Pixel Data Format	8 / 10 / 12 bit		
Electronic Shutter	Global Shutter		
Data Output Pixel Clock Speed	40 MHz (1 or 2 Tap) / 80 MHz (4 Tap)		
Trigger Mode	Free-Run, Standard, Fast, Double, Overlap Programmable Exposure Time and Trigger Polarity		
Dynamic Range	64 dB		
Binning	×1, ×2, ×4 (Horizontal and Vertical Independent)		
Lookup Table	User Defined Lookup Table (LUT)		
Analog Offset	Adjustable (0 ~ 127 LSB at 12 bit, 256 steps)		
Analog Gain	0 ~ 32 dB, 900 steps		
Dimension / Weight	68 mm × 68 mm × 54 mm, 420 g (with C-mount) 68 mm × 68 mm × 83 mm, 460 g (with F-mount)		
Temperature	Operating: -5°C ~ 40°C, Storage: -40°C ~ 70°C		
Lens Mount	C or F-mount, Custom mount available upon request		
Power	10 ~ 14 V DC, Typ. 6 W	10 ~ 14 V DC, Typ. 6.5 W	10 ~ 14 V DC, Typ. 6.5 W
Compliance	CE, FCC, KC		
Configuration Software	Configurator		

VA-1MC / VA-2MC / VA-4MC / VA-8MC / VA-16MC / VA-29MC

1 / 2 / 4 / 8 / 16 / 29 MEGAPIXEL RESOLUTION - HIGH-SPEED PROGRAMMABLE DIGITAL CAMERA

Specifications

Model	VA-8MC-M/C 16	VA-16MC-M/C 8	VA-29MC-M/C 5
Resolution (H × V)	3296 × 2472	4896 × 3264	6576 × 4384
Sensor (ON Semiconductor)	KAI-08051	KAI-16050	KAI-29050
Sensor Size (Optical Format)	4/3"	32 mm (APS-H)	35 mm
Sensor Type	Progressive Scan Interline Transfer CCD		
Pixel Size	5.5 μm × 5.5 μm		
Sensor Output	1, 2 or 4 Tap		
Interface	Camera Link		
Max. Frame Rate	16 fps	8 fps	4.8 fps
Exposure Time	1/100000 ~ 7 s (10 μs step)		
Partial Scan (Max. Speed)	84 fps at 300 Lines	23 fps at 1000 Lines	15.2 fps at 1000 Lines
Pixel Data Format	8 / 10 / 12 bit		
Electronic Shutter	Global Shutter		
Data Output	40 MHz (1 or 2 Tap)	Low Speed: 30 MHz (1/2 Tap) / 60 MHz (4 Tap)	
Pixel Clock Speed	80 MHz (4 Tap)	High Speed: 40 MHz (1/2 Tap) / 80 MHz (4 Tap)	
Trigger Mode	Free-Run, Standard, Fast, Double, Overlap Programmable Exposure Time and Trigger Polarity		
Dynamic Range	66 dB	64 dB	
Binning	×1, ×2, ×4 (Horizontal and Vertical Independent)		
Lookup Table	User Defined Lookup Table (LUT)		
Analog Offset	Adjustable (0 ~ 127 LSB at 12 bit, 256 steps)		
Analog Gain	0 ~ 32 dB, 900 steps		
Dimension / Weight	68 mm × 68 mm × 54 mm, 420 g (with C-mount) 68 mm × 68 mm × 83 mm, 460 g (with F-mount)		68 mm × 68 mm × 104 mm 500 g (with F-mount)
Temperature	Operating: -5°C ~ 40°C, Storage: -40°C ~ 70°C		
Lens Mount	C or F-mount	F-mount, Custom mount available upon request	
Power	10 ~ 14 V DC, Typ. 7 W	10 ~ 14 V DC, Typ. 8 W	10 ~ 14 V DC, Typ. 9.5 W
Compliance	CE, FCC, KC (Application of VA-16MC in preparation)		
Configuration Software	Configurator		

Ordering Scheme

VA - 29M C - M 5 AO	
Series VA Series	Sensor Options AO - ON Semiconductor
Sensor Resolution 1M - 1 Megapixels 2M - 2 Megapixels 4M - 4 Megapixels 8M - 8 Megapixels 16M - 16 Megapixels 29M - 29 Megapixels	Frame Rate 5 - 4.8 fps 8 - 8 fps 16 - 16 fps 32 - 33 fps 68 - 70 fps 120 - 125 fps
Interface C - Camera Link	Mono / Color M - Monochrome C - Color

Connector Specification

Power



1 2 3: +12V DC, 4 5 6: GND
(HR10A-7R-6PB)

Control

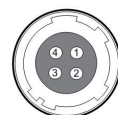

1: Trigger IN+, 2: Trigger IN-
3: DC Ground, 4: Strobe OUT+
(HR10A-7R-4S)

Connectors on camera body

VA-1MC / VA-2MC / VA-4MC / VA-8MC / VA-16MC / VA-29MC

1 / 2 / 4 / 8 / 16 / 29 MEGA PIXEL RESOLUTION - HIGH-SPEED PROGRAMMABLE DIGITAL CAMERA

Mechanical Dimensions

Unit: mm

C-mount

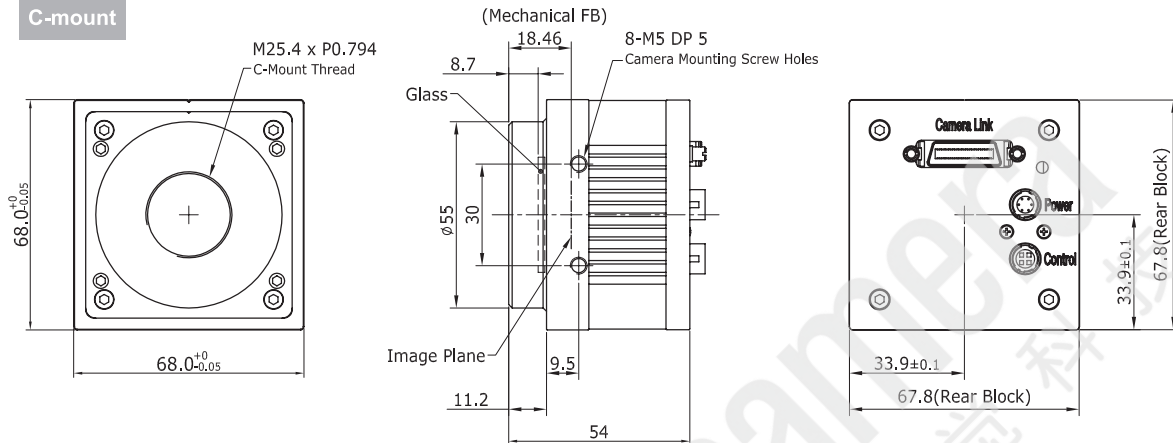

F-mount

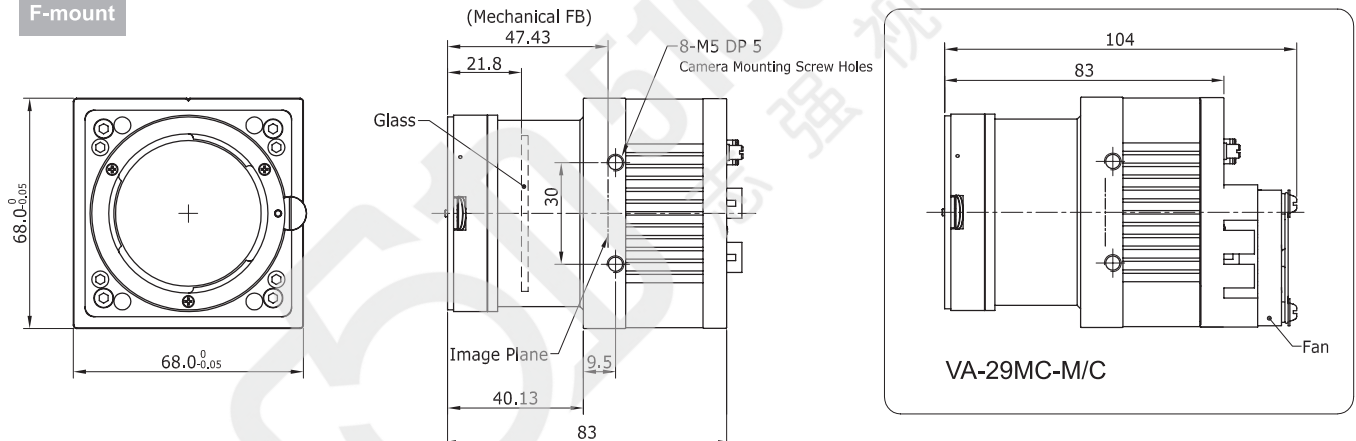

For more information please contact local distributor or visit our website at <http://www.vieworks.com>.

Reproduction in whole or in part without written permission is prohibited. Vieworks Co., Ltd. is not responsible for any technical or typographical errors and reserves the right to make changes to products, specifications and documentation without prior notice.

RA14-11A-008

VIEWORKS

41-3, Burim-ro 170 beon-gil, Dongan-gu, Anyang-si, Gyeonggi-do, 14055 Republic of Korea
tel +82-70-7011-6161 fax +82-31-386-8631 e-mail sales@vieworks.com