

Genie TS-C3500

Area Scan Color Cameras

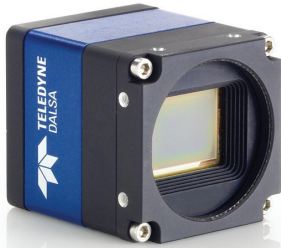

Genie TS-C3500

Key Features

- Uses standard PC Ethernet port & hardware
- Supports cable lengths up to 100 m (CAT-5e or CAT-6)
- Simplified set-up with field proven Sopera Essential software featuring CamExpert
- Engineered to accommodate industrial environment with a Ruggedize, screw mount, RJ-45 connector
- Auto-Iris (Video, DC or Motorized)

Programmability

- Higher frame rates achievable in partial scan mode
- Global electronic shutter with exposure Control
- Auto-Brightness Feature
- Extended Dynamic Range Function
- On-board flat-field correction
- Multi-Exposure Feature
- Programmable LUTs
- On-board Image compression
- Transfer On-Demand Function
- IEEE1588 Precise time Protocol

Typical Applications

- Electronics manufacturing inspection
- Industrial metrology
- Intelligent traffic systems

Overview

Small compact GigE Vision camera with uncompromised image quality.

The Genie TS-C3500 uses a Teledyne DALSA CMOS, color sensor with a resolution of 3520 x 2200. Teledyne DALSA's proprietary sensor technology allows for image capture rates of 19 fps in 8M pixels resolution while maintaining exceptional image quality. The Genie TS-C3500 takes advantage of gigabit Ethernet technology, transmitting data over standard CAT-5e and CAT-6 cables to distances of up to 100 m. Like all Genie cameras, the TS-C3500 is based on AIA (Automated Imaging Association) GigE Vision Standard to directly link the camera to a PC.



Specifications

Active Resolution	3520 x 2200
Acquisition Frame Rate	19 fps
Data Output Transfer	Gigabit Ethernet, also supports 100 Mbps
Pixel Size	6.0 μ m
Data Format	8 and 10-bits Raw Bayer
Exposure Control	Automatic, Programmable, or via External Trigger
Dynamic Range	60 dB
Gain Control	Automatic, Manual and One-Push Gain modes
I/O Ports	4 opto-isolated input, 4 opto-isolated output, 3 motorized Control, RS-485 Port, and RS-232 Port
Image Buffer	512MB of On-board memory
Lens Mount	M42 x1mm
Size	49 mm x 49 mm x 54 mm
Mass	~196 g
Operating Temp	-20° to +60°C
Power Supply	12 to 24V or Power Over Ethernet (POE)
Power Dissipation	~4.5 to 5.5W
Data Connector	Standard or Screw mount RJ-45
Power and I/O	Micro-D 25-pin and 4-pin auto-Iris
Regulatory Compliance	FCC Class A, CE, RoHs 2004/105/EC
Camera Specification	GigE Vision v1.2 Compliant
Software Platform	Teledyne DALSA Sopera LT or 3rd Party Genicam Compliant SDK
Part Number	G2-GC10-T3505

Genie TS-C3500

Area Scan Color Cameras

All Genie cameras feature value added functionality designed specifically for imaging and machine vision applications. All features are easily accessible with Teledyne DALSA's advanced software tools. These tools deliver superior image capture, performance, and control.

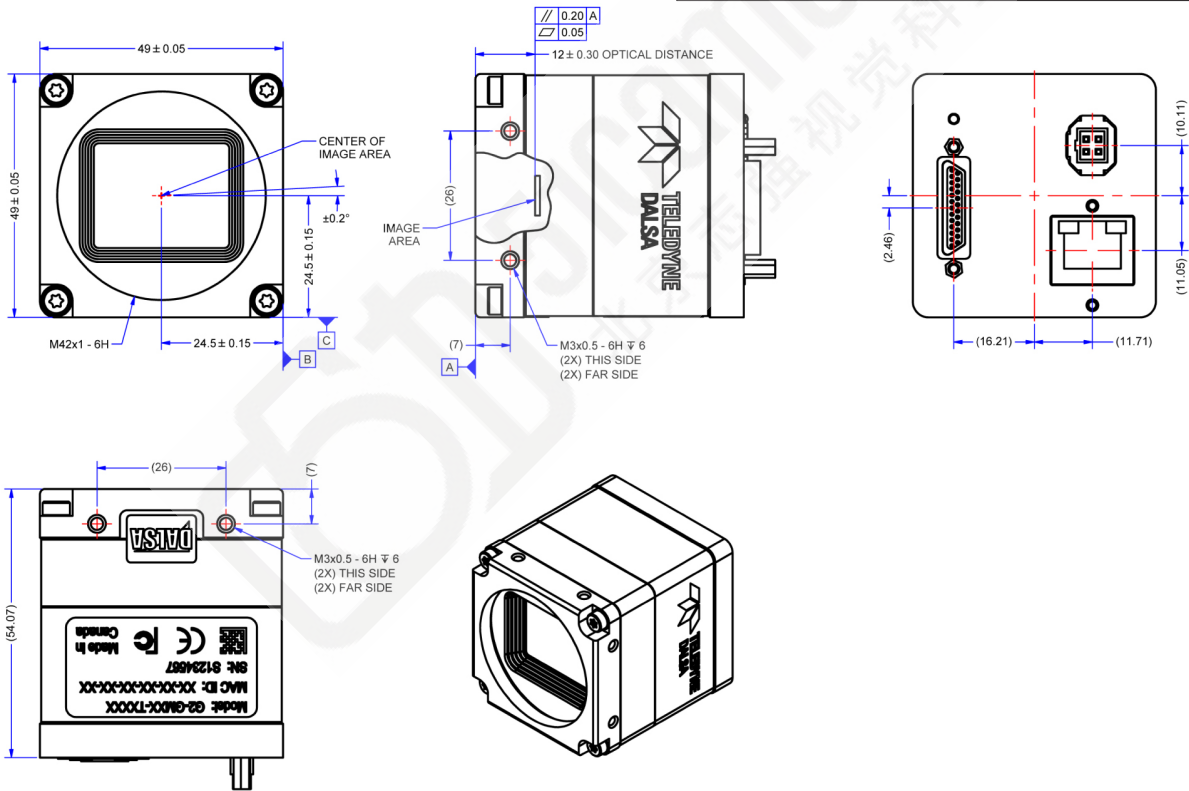
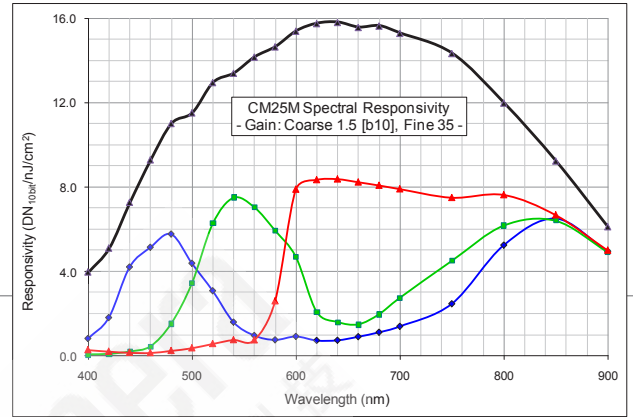

NOTES:
 1. UNITS: MILLIMETERS.
 2. IMAGE AREA IS ALIGNED TO DATUMS A, B & C

www.teledynedalsa.com

Americas

Boston, USA
 +1 978-670-2000
sales.americas@teledynedalsa.com

Europe

Krailling, Germany
 +49 89-89-54-57-3-80
sales.europe@teledynedalsa.com

Asia Pacific

Tokyo, Japan
 +81 3-5960-6353
sales.asia@teledynedalsa.com

Shanghai, China
 +86 21-3368-0027
sales.asia@teledynedalsa.com

Teledyne DALSA has its corporate offices in Waterloo, Canada
 Teledyne DALSA reserves the right to make changes at any time without notice. Teledyne DALSA © 2012.

